



PIR sensor



Emergency lighting



Smoke detector



Eurovent certification



Tested to VDI 6022

Freely suspended units

Type SMART BEAM



Multi-service active chilled beam with two-way air discharge and horizontal heat exchanger

Active chilled beam for heating and cooling, with 2-pipe or 4-pipe heat exchanger, for freely suspended installation; additional functions or services (e.g. lighting, loudspeakers, sprinklers, smoke detectors, or PIR sensors) can be integrated

- Preferably for room heights up to 4.00 m
- High heating and cooling capacity with a low conditioned primary air volume flow rate and low sound power level
- High comfort levels as a result of low airflow velocities in the occupied zone
- Unit consists of three parts: wall end, active section, and front end
- Four nozzle variants to optimise induction based on demand

Optional equipment and accessories

- Control system
- 3 different front ends
- Various services, e.g. lighting, sprinklers, smoke detectors, PIR sensors, and loudspeakers
- Powder coating in many different colours, e.g. RAL CLASSIC

Type		Page
SMART BEAM	General information	SB – 2
	Function	SB – 4
	Technical data	SB – 6
	Quick sizing	SB – 7
	Specification text	SB – 8
	Order code	SB – 9
	Dimensions and weight	SB – 11
	Installation examples	SB – 12
	Installation details	SB – 13
	Basic information and nomenclature	SB – 14

Application

Application

- Active chilled beams of Type DID-SB (SMART BEAM) for freely suspended installation, preferably for room heights up to 4.00 m
- Project-specific integration of functions or services such as lighting, loudspeakers, sprinklers, smoke detectors, or PIR sensors
- Integral strip light fittings use innovative microprism optics to provide uniform illumination of rooms
- Each section can be individually designed
- 2-pipe or 4-pipe heat exchangers enable good comfort levels with a low conditioned primary air volume flow rate
- Energy-efficient solution since water is used for heating and cooling

Special characteristics

- Freely suspended active chilled beam with choice of different face plate perforations
- Heat exchanger as 2-pipe or 4-pipe system
- Wide range of additional services such as

- lighting, sprinklers, loudspeakers and sensors (accessories)
- Water connections at the narrow side, Ø12 mm Cu pipe, with plain tails or with G½" external thread, or with a G½" union nut; with flat seal
- Wall end
 - Cover for air and water connections at the end facing the wall
 - Connection of project-specific services

Active section

- Air discharge and heat exchanger
- Integration of different functions, e.g. acoustic fleece, lighting or sensors

Front end

- Available in three designs
- Integration of project-specific functions, e.g. loudspeakers

Nominal sizes

- 3000 mm

Description

Variants

- Induced air grille with various perforation patterns

Heat exchanger

- 2: 2-pipe systems
- 4: 4-pipe systems

Nozzle variants

- K: Small
- Z: Small plus
- M: Medium
- G: Large

Front end

- Circular
- Straight
- Slanted

Construction

- Powder-coated RAL 9010, pure white, gloss level 50 %
- P1: Powder-coated in any other RAL colour, gloss level 70 %
- P1: Powder-coated RAL 9006, white

aluminium, gloss level 30 %

Attachments

- Water connection A1: G½" external thread and flat seal
- Water connection A2: G½" union nut and flat seal

Accessories

- Sprinkler
- Smoke detector
- PIR sensor
- Loudspeaker
- Indirect and/or direct lighting
- Volume flow controller

Useful additions

- Connecting hoses
- Control equipment consisting of a control panel including a controller with integral room temperature sensor; valves and valve actuators; and lockshields (no lighting control)
- X-AIRCONTROL control system

Construction features

- Spigot is suitable for circular ducts to EN 1506

- or EN 13180
- Unit consists of three parts: wall end, active section, and front end
- Four suspension points for on-site installation (by others)
- Four nozzle variants to optimise induction based on demand
- Perforated front plate (choice of different designs) with acoustic fleece at the rear

Materials and surfaces

- Wall end as well as active section with front plate and cross bars are made of galvanised sheet steel
- Front end made of aluminium or galvanised sheet steel
- Heat exchanger with copper tubes and aluminium fins
- Exposed surfaces at the front are powder-coated pure white (RAL 9010) or in any other RAL colour
- Exposed surfaces at the rear, including nozzle

- box, in RAL 9006, white aluminium
- Heat exchanger also available in RAL 9006, white aluminium
- Nozzle plate made of sheet steel

Standards and guidelines

- Products are certified by Eurovent (no. 09.12.432) and listed on the Eurovent website
- Declaration of hygiene conformity to VDI 6022

Maintenance

- No moving parts, hence low maintenance
- Heat exchanger is easily accessible for cleaning
- The heat exchanger can be vacuumed with an industrial vacuum cleaner if necessary
- VDI 6022, Part 1, applies (Hygiene requirements for ventilation and air-conditioning systems and units)

Functional description

Active chilled beams provide centrally conditioned primary air (fresh air) to the room and use heat exchangers for additional cooling and/or heating. The primary air is discharged through nozzles

(four variants are available).

As a result of this, secondary air (room air) is induced and passes through the heat exchanger. Primary and secondary air mix and are then supplied to the room horizontally.

Schematic illustration of DID-SB

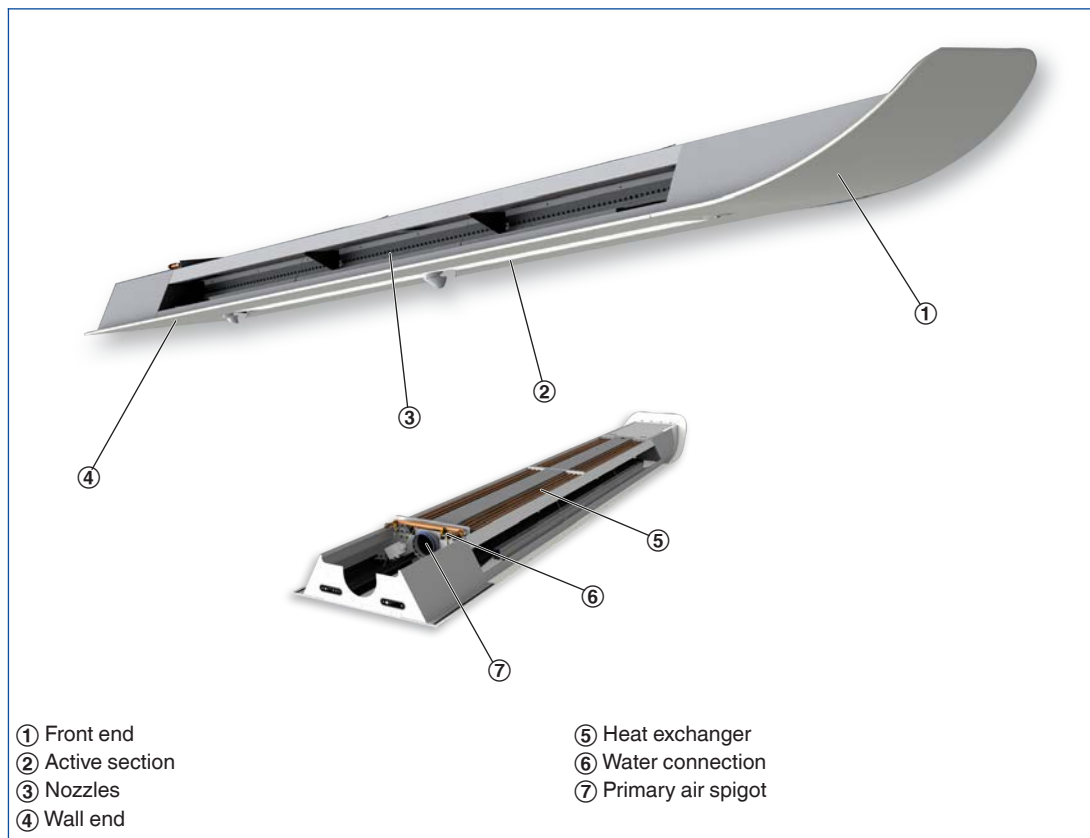

Principle of operation – DID-SB

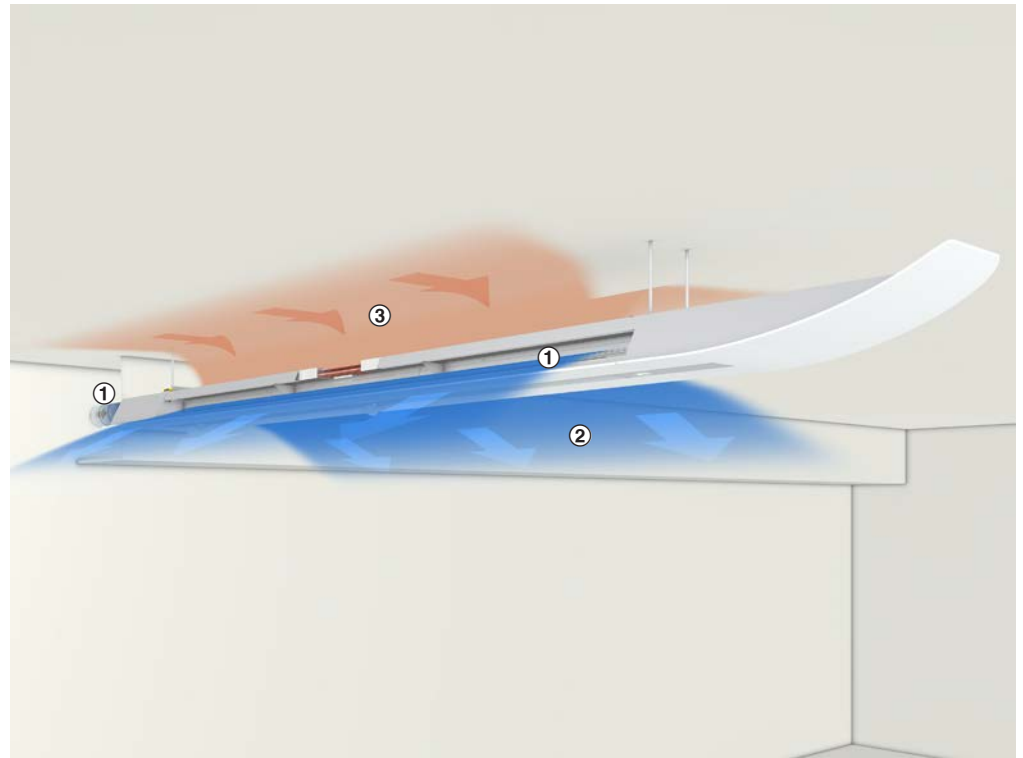

- ① Conditioned fresh air (primary air)
- ② Supply air

- ③ Room air (secondary air)

Length	4500 – 5200 mm
Width	750 mm
Height	291 mm (plus services)
Primary air spigot, diameter	123 mm
Primary air volume flow rate	8 – 33 l/s or 30 – 120 m ³ /h
Cooling capacity	Up to 1000 W
Heating capacity	Up to 750 W
Max. operating pressure, water side	6 bar
Max. operating temperature, water side	75 °C

The quick sizing table contains operating points for defined reference units.

Quick sizing

L _N	①	Primary air			② L _{WA} dB(A)	Cooling				Heating		
		V _{Pr} l/s	V _{Pr} m ³ /h	Δp _t Pa		2-pipe and 4-pipe systems				4-pipe system		
						Q̇ _{tot} W	Q̇ _{WK} W	Δt _w K	Δp _w kPa	Q̇ _{WH} = Q̇ _{tot} W	Δt _w K	Δp _w kPa
3000	K	13	47	88	<20	524	366	1.6	4.0	190	2.7	0.21
		16	58	133	23	655	461	2.0	4.0	455	6.5	0.21
		21	76	228	31	830	576	2.5	4.0	744	10.7	0.21
	Z	17	61	51	<20	483	279	1.2	4.0	400	5.7	0.21
		21	76	79	<20	664	409	1.8	4.0	626	9.0	0.21
		25	90	111	24	806	505	2.2	4.0	780	11.2	0.21
	ZM	20	72	45	<20	521	280	1.2	4.0	508	7.3	0.21
		24	86	64	<20	686	398	1.7	4.0	673	9.6	0.21
		28	101	89	23	837	499	2.1	4.0	809	11.6	0.21
	M	22	80	39	<20	535	267	1.2	4.0	545	7.8	0.21
		27	97	57	<20	732	407	1.8	4.0	710	10.2	0.21
		31	112	76	23	881	506	2.2	4.0	824	11.8	0.21
	G	35	126	33	21	815	393	1.7	4.0	637	9.1	0.21
		40	144	43	25	969	486	2.1	4.0	726	10.4	0.21
		45	162	54	28	1108	565	2.4	4.0	801	11.5	0.21

① Nozzle variant

② Air-regenerated noise

Reference values

Parameter	Cooling	Heating
t _R	26 °C	22 °C
t _z	16 °C	22 °C
t _{wv}	16 °C	50 °C
V _w	200 l/h	60 l/h

L_N = 3000 mm
X = 1.5 m
R_H = 3.2 m
A = 3.0 m

This specification text describes the general properties of the product.

Description

Active chilled beams of Type DID-SB, with two-way air discharge and high thermal output, providing high thermal comfort levels; for visible installation about 300 mm below the ceiling slab in rooms without a suspended ceiling.

Preferably for room heights up to 4.00 m.

The units consist of a casing with suspension points, a spigot, non-combustible nozzles, and a horizontal heat exchanger.

Four nozzle variants to optimise induction based on demand.

Special characteristics

- Freely suspended active chilled beam with choice of different face plate perforations
 - Heat exchanger as 2-pipe or 4-pipe system
 - Wide range of additional services such as lighting, sprinklers, loudspeakers and sensors (accessories)
 - Water connections at the narrow side, Ø12 mm Cu pipe, with plain tails or with G½" external thread, or with a G½" union nut; with flat seal
- Wall end
- Cover for air and water connections at the end facing the wall
 - Connection of project-specific services

Active section

- Air discharge and heat exchanger
- Integration of different functions, e.g. acoustic fleece, lighting or sensors

Front end

- Available in three designs
- Integration of project-specific functions, e.g. loudspeakers

Materials and surfaces

- Wall end as well as active section with front plate and cross bars are made of galvanised sheet steel
- Front end made of aluminium or galvanised sheet steel
- Heat exchanger with copper tubes and aluminium fins

- Exposed surfaces at the front are powder-coated pure white (RAL 9010) or in any other RAL colour
- Exposed surfaces at the rear, including nozzle box, in RAL 9006, white aluminium
- Heat exchanger also available in RAL 9006, white aluminium
- Nozzle plate made of sheet steel

Construction

- Powder-coated RAL 9010, pure white, gloss level 50 %
- P1: Powder-coated in any other RAL colour, gloss level 70 %
- P1: Powder-coated RAL 9006, white aluminium, gloss level 30 %

Technical data

- Length: 4500 – 5200 mm
- Height: 291 mm (plus services)
- Width: 750 mm
- Primary air spigot, diameter: 123 mm
- Primary air volume flow rate: 8 – 33 l/s or 30 – 120 m³/h
- Cooling capacity: up to 1000 W
- Heating capacity: up to 750 W
- Max. operating pressure: 6 bar
- Max. operating temperature: 75 °C

Sizing data

Primary air

- \dot{V} _____
[m³/h]
- Δp_t _____
[Pa]

Air-regenerated noise

- L_{WA} _____
[dB(A)]

Cooling

- \dot{Q}_{ges} _____
[W]

Heating

- \dot{Q}_{ges} _____
[W]

DID-SB

DID-SB - 4 - M - A1 / 3000 x 750 / 123 / P1 - RAL... / G4 / T16 / Z1 - Z2 - Z4 - Z5 - Z6 - Z7 / D1 / S / VS

1 Type

DID-SB Active chilled beam

2 Heat exchanger

2 2-pipe
4 4-pipe

3 Nozzle variant

K Small
Z Small plus
M Medium
G Large

4 Water connections

No entry: Ø12 mm pipe with plain tails
A1 With G½" external thread and flat seal
A2 With G½" union nut and flat seal

5 Nominal size (active section x wall end) [mm]

3000 x 500
3000 x 750
3000 x 1000

6 Spigot diameter [mm]

123

7 Exposed surface

No entry: powder-coated
RAL 9010, pure white
P1 Powder-coated, specify RAL CLASSIC colour

Gloss level
RAL 9010 50 %
RAL 9006 30 %
All other RAL colours 70 %

8 Surface of heat exchanger

No entry: untreated
G4 White aluminium, RAL 9006, gloss level 30 %

9 Light fitting

T16 Direct light MPO-D 2x2/28 T16 LDE; indirect light MPO-D 2x1/28 T16 LDE
LED Direct light MPO-D LED 96W; indirect light EBL-ID LED, electronic ballast

10 Accessories

Z1 Sprinkler bushing, pos. 1
Z2 Sprinkler bushing, pos. 2
Z3 One loudspeaker
Z4 Two loudspeakers
Z5 Smoke detector
Z6 Emergency lighting
Z7 PIR sensor

11 Surface design

D1 Hadi Teherani perforation

12 Front end

No entry: circular
G Straight
S Slanted (45° angle)

13 Valves and actuators

No entry: none
VS With

Order examples

DID-SB-2-M-3000x500/123/T16/D1

Heat exchanger	2-pipe
Nozzle variant	Medium
Water connections	Ø12 mm pipe, plain tails
Nominal size	3000 × 500 mm
Spigot diameter	123 mm
Exposed surface	RAL 9010, pure white
Surface of heat exchanger	Untreated
Light fitting	T16
Surface design	Hadi Teherani perforation
Front end	Circular

DID-SB-4-G-3000x1000/123/P1/RAL 9006/G4/LED/Z4-Z5-Z6-Z7/D1/S/VS

Heat exchanger	4-pipe
Nozzle variant	Large
Water connections	Ø12 mm pipe, plain tails
Nominal size	3000 × 1000 mm
Spigot diameter	123 mm
Exposed surface	P1 RAL 9016, traffic white
Surface of heat exchanger	RAL 9006, white aluminium
Light fitting	LED
Accessories	Two loudspeakers, smoke detector, emergency lighting, PIR sensor
Surface design	Hadi Teherani perforation
Front end	Slanted
Valves and actuators	With

Dimensions

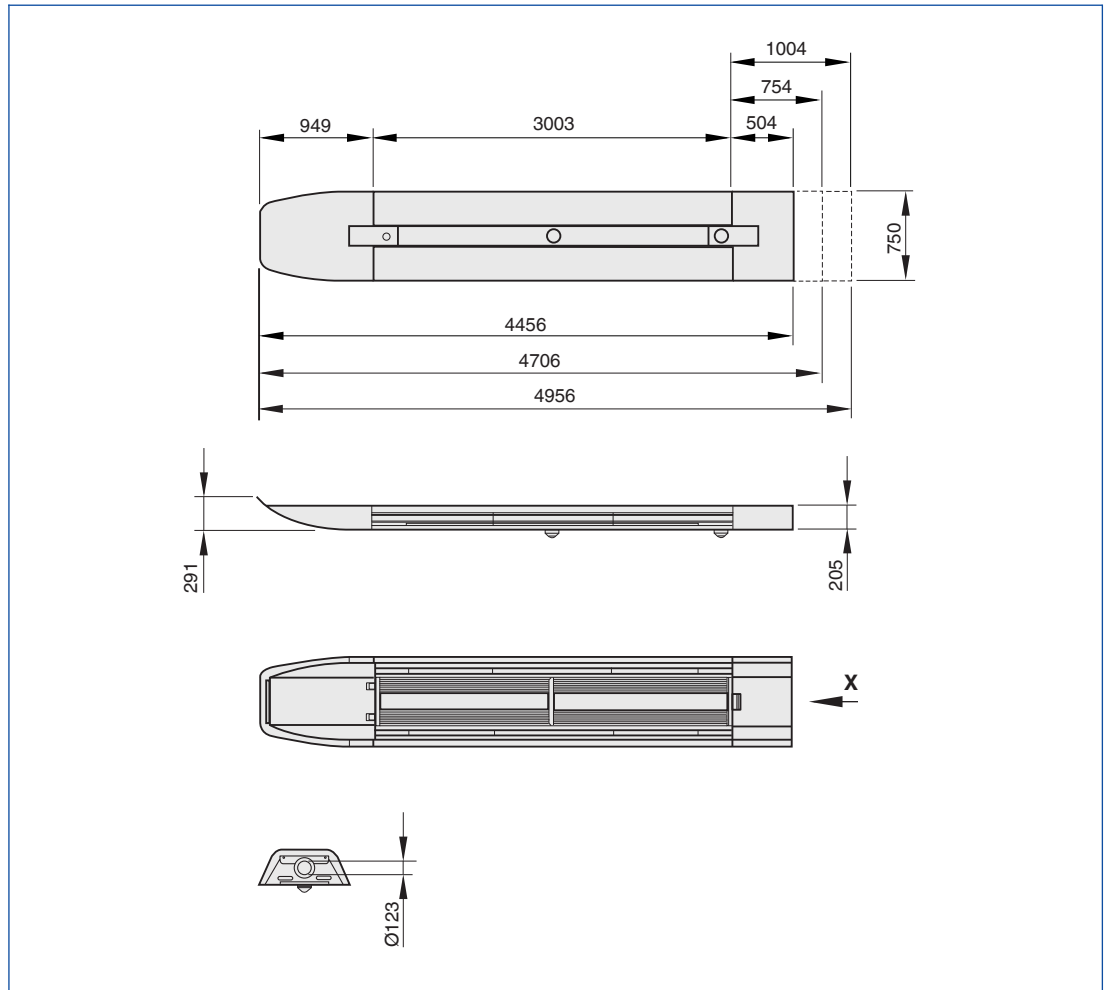

Weight [kg]

Length	3000/500	3000/750	3000/1000
Contained water (max.)	6	6	6
Unit with rounded front end, without accessories	140	145	150
All accessories + cable	10	10	10
Straight or slanted front end	5	5	5

Installation example



Installation example



Installation and commissioning

- Preferably for rooms with a clear height up to 4.00 m
- Freely suspended installation
- Side entry primary air spigot
- Total length 4500 – 5200 mm, width 750 mm
- Installation and connections to be performed by others; fixing, connection and sealing material to be provided by others
- Active chilled beam has 4 suspension points for on-site installation (by others)
- Heat exchangers are fitted with water flow and water return connections

L_N [mm]

Nominal length

L_{WA} [dB(A)]

Sound power level

t_{Pr} [°C]

Primary air temperature

t_{WV} [C°]

Water flow temperature – cooling/heating

t_R [C°]

Room temperature

t_R [C°]

Room temperature

t_{AN} [C°]

Secondary air intake temperature

Q_{Pr} [W]

Thermal output – primary air

Q_{tot} [W]

Thermal output – total

Q_W [W]

Thermal output – water side, cooling/heating

\dot{V}_{Pr} [l/s]

Primary air volume flow rate

\dot{V}_{Pr} [m³/h]

Primary air volume flow rate

\dot{V}_W [l/h]

Water flow rate – cooling/heating

\dot{V} [l/h]

Volume flow rate

Δt_W [K]

Temperature difference – water

Δp_W [kPa]

Pressure drop, water side

Δp_t [Pa]

Total pressure drop, air side

$\Delta t_{Pr} = t_{Pr} - t_R$ [K]

Difference between primary air temperature and room temperature

$\Delta t_{RWV} = t_{WV} - t_R$ [K]

Difference between water flow temperature and room temperature

Δt_{Wm-Ref} [K]

Difference between mean water temperature and reference temperature

L_N [mm]

Nominal length

Mixed flow

The supply air is discharged from the diffuser into the space with a velocity between 2 and 5 m/s. The resulting air jet mixes with the room air, ventilating the entire space. Mixed flow systems typically provide a uniform temperature distribution and air quality within the space. The originally high velocity of the turbulent air jet decreases rapidly due to the high induction levels of mixed flow systems.

Schematische Darstellung Mischlüftung

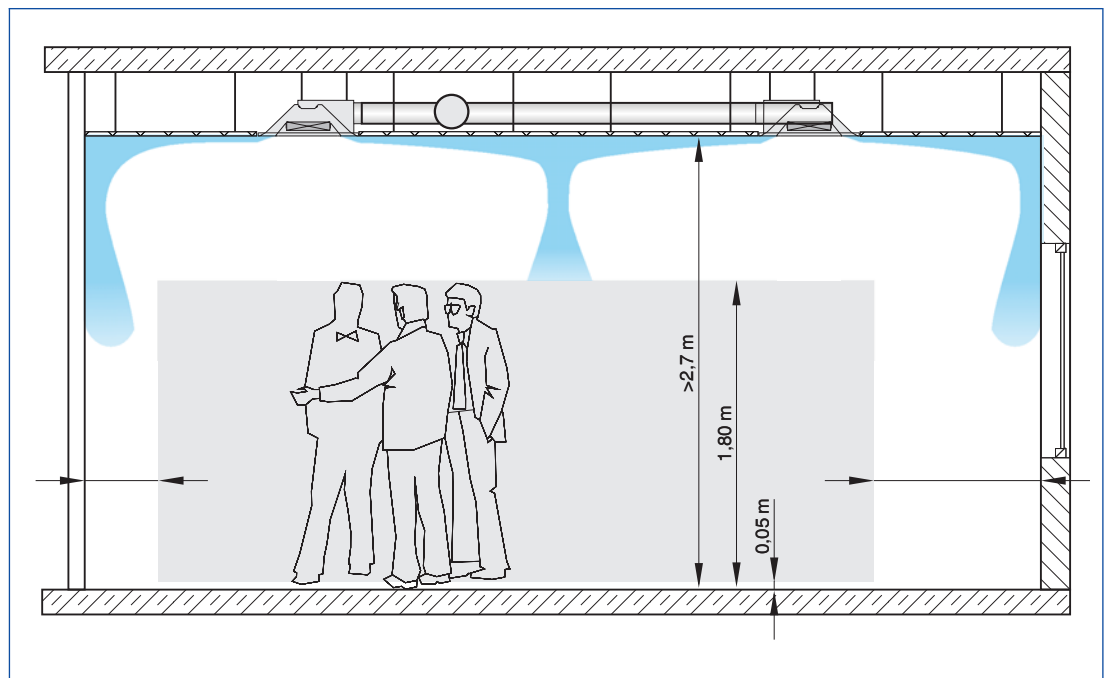

Heat exchanger

The maximum water-side operating pressure for all heat exchangers is 6 bar.
The maximum water flow temperature (heating circuit) for all heat exchangers is 75 °C; if flexible hoses are used, the water flow temperature should not exceed 55 °C. Units for other pressures

and temperatures are available on request.
The water flow temperature (cooling circuit) should be at least 16 °C such that it does not permanently fall below the dew point. For units with a condensate drip tray the water flow temperature may be reduced to 15 °C.

Heat exchanger as 2-pipe system

Air-water systems with a 2-pipe heat exchanger may be used for either heating or cooling. In

changeover mode it is possible to use all units within a water circuit exclusively for cooling in summer and exclusively for heating in winter.

Wärmeübertrager 2-Leiter-System

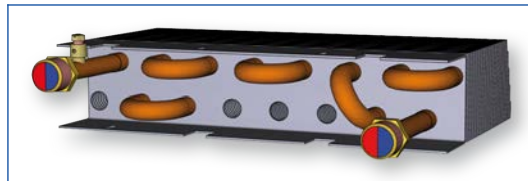

Heat exchanger as 4-pipe system

Air-water systems with a 4-pipe heat exchanger may be used for both heating and cooling. Depending on the season, i.e. especially in spring

and autumn, it may be possible that an office has to be heated in the morning and cooled in the afternoon.

Wärmeübertrager 4-Leiter-System

