

## BACnet Technical Reference

### Scope

This document covers firmware 4.9 with configuration file FCU403 TRX and any derivatives of this initial set up.

### Network Configuration

MS/TP allows for only a daisy-chained network configuration, consisting of a single cable routed between controllers. Star and Ring network topologies are not supported.

The network supports a maximum of 254 nodes; addresses 0 to 127 are valid for both master and slave nodes and addresses 128 to 254 are valid only for slave nodes.

To comply with the EIA-485 standard, the maximum number of nodes per segment shall be 32 and any additional nodes will require the use of repeaters. If only Titan controllers are on the MS/TP network, the number of controllers may be increased to 127 dependent on wiring length as specified below.

A termination resistance of 120 ohms shall be connected at each of the two ends of the segment medium.

### Cable Specifications

- All signal cables must be segregated from any low voltage mains carrying inductors and they should not be run in the same containment system.
- All signal cables must not run in close proximity to any mains AC inductive loads such as fluorescent fittings and electric motors.
- All cable connections into Titan Products controllers should use ferrules to prevent short circuits

The cable used in an MS/TP EIA-485 network should conform to the following specifications:

Wire Size:	22-24 AWG
Cable Type:	Twisted-pair, copper wire, tinned and a ground wire which must be connected to all devices on the 485 network.
Shield:	Foil or braided
Nominal Impedance:	100 – 130 $\Omega$
Capacitance:	< 100 pF/m distributed capacitance between conductors < 200 pF/m distributed capacitance between conductors and shield
Max segment length:	1200 meters (4000 feet)

The cable shield must be connected to Earth ground at the network router end only.

The recommended cable is Belden 3106A or equivalent. Select a good quality cable suitable for the RS485 standard. Belden 3106A is 22AWG.

### BACnet Network Configuration

Based on the standards for RS485 networks a BACnet MS/TP network layer allows for only a daisy-chained network configuration, consisting of a single cable routed between controllers. **Star and Ring network topologies are not supported.**

The network electrically supports a maximum of 127 nodes, however BUS network size capability is determined by factors such as network traffic and BMS capabilities and we recommend maximum network size of 32 or 64 devices.

To comply with the EIA-485 standard, the maximum number of nodes per segment shall be 32 and any additional nodes will require the use of repeaters. If only Titan controllers are on the MS/TP network, the number of controllers may be increased but this will depend on the network traffic, the baud rate being used and the length/route of the cable.

TITAN FCU403  
(Firmware v4.9, Config. FCU403 TRX) / Graphical RDU (V2)

A termination resistor of 120 ohms should be connected at each of the end devices, when a network is connected to a Router or BMS this becomes one of the end devices. Please check with the Router/BMS manufacturer if the 120 ohms end of line resistor is fitted internally.

The Common wire serves an important purpose. Over long network distances, there can be very significant differences in the voltage levels of the devices on RS485 network. The function of the signal common wire is to tie each of the control devices to one common reference. Without this, data can be lost or the device RS485 ports could be damaged.

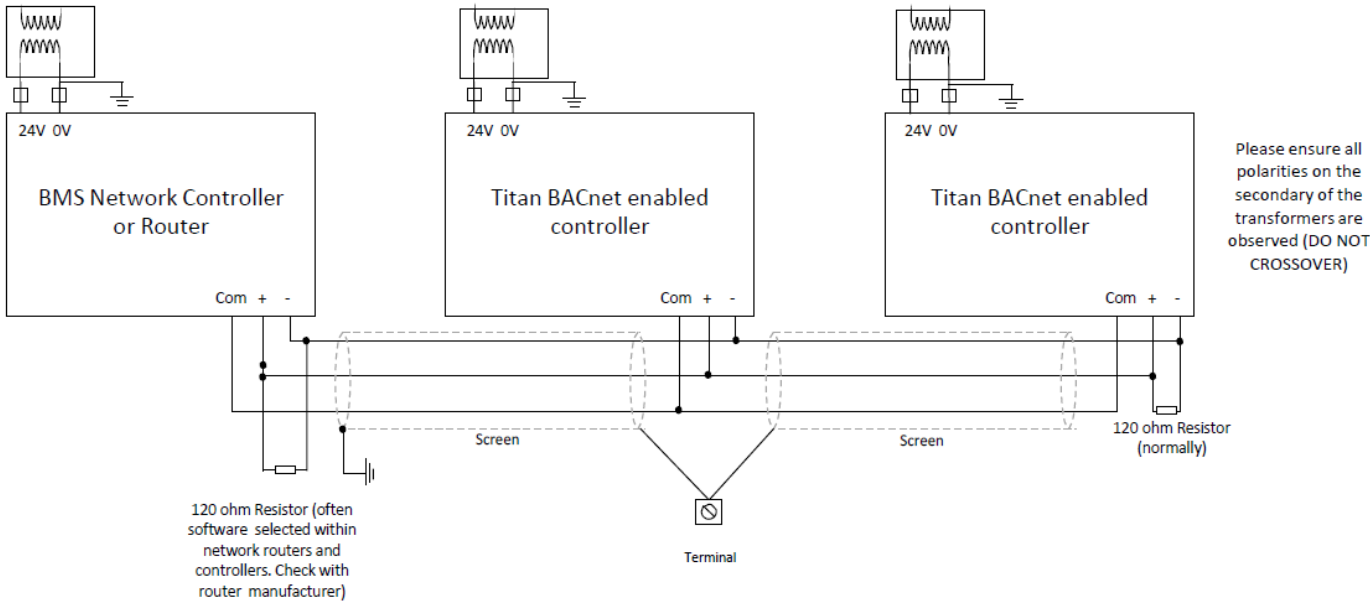

The above diagram shows a typical 3-wire daisy chain configuration. For all BACnet standard wiring variants please consult ASHRAE wiring standards.

### Commissioning Settings

The BACnet commissioning settings can be accessed on the graphical RDU or programming tool by simultaneously pressing all four buttons. The left buttons can be used to scroll through the menu selections and the right buttons to change settings. To navigate and access the engineers settings please see supporting documentation.

The following settings need to be commissioned before connection to the MS/TP network:

**BACnet Device Object Identifier:** This setting allows the entry of a unique internetwork wide BACnet Device Object Identifier. With a default setting of 0000000, the device will operate on the local MS/TP network but will not dynamically bind and initiate I\_Am messages. A valid Device Object ID in the range 1 to 4194302 can be entered and this will set the Device Object Name to "FCU4 *DevObjectID*".

**MAC Address:** This setting corresponds to a unique MAC address on the local MS/TP network and can be in the range 1 to 127.

**Baud Rate:** This setting corresponds to the MS/TP network Baud Rate and should match all other devices on the same local network. Options are 9600, 19200, 38400 and 76800.

## FCU4 Group Operation

Multiple FCU4's can function as part of a group, consisting of one Group\_Master and one or more Group\_Slaves. The desired Group Control can be selected in the Engineers settings or via BACnet. The following parameters are distributed by the Group\_Master to the associated Group\_Slaves:

Object ID	Object Name
*AI 100	S1
*AI 101	S1
*AI 1	In1A
*AI 2	In2A
*AI 3	In3A
*AI 4	In4A
*AI 5	In5A
*AI 700	RDU Temp
*BI 1	In1D
*BI 2	In2D
*BI 3	In3D
*BI 4	In4D
*BI 5	In5D
BV 51	VB1
BV 52	VB2
*BI 700	Card Status
AV 300	Set Point
MSV 605	User Fan
AV 604	Occ OR Time
MSV 701	Guest request
BV 709	Active flush
MSV 618	HeatCool Ctrl
BV 1000	Transmit All

\*A Group\_Slave will only use a grouped input if the local input is 'out of service'.

The following settings control the grouping:

**Group Type:** This setting specifies the type of group member and can be set to None, Group\_Master or Group\_Slave.

**Group Number:** This setting corresponds to a unique FCU4 grouping on the local MS/TP network in the range 1 to 64. All controllers belonging to the group use an identical grouping number and another separate group would use a differing grouping number.

**Update Period:** The time in the range 1 to 300 seconds between group transmissions.

**Full Update:** This setting is used during commissioning to send the full list of BACnet Objects around the group rather than the reduced list shown above. Following the update, the Group\_Slaves will save the received values to FLASH memory and reboot. This option may be set to Never, Reboot or Once. If set to Reboot, the action will occur every time the Group\_Master reboots. If set to Once, the action will occur when the Group\_Master next reboots. The option will then be automatically cleared to Never.

## Object Description

The tables below indicate the Objects supported by the FCU4 and the function they perform.

Object ID	Object Name	Function
AI 100	S1	Thermistor input S1
AI 101	S2	Thermistor input S2
AI 1	In1A	The analog signal present on Input 1.
AI 2	In2A	The analog signal present on Input 2.
AI 3	In3A	The analog signal present on Input 3.
AI 4	In4A	The analog signal present on Input 4.
AI 5	In5A	The analog signal present on Input 5.
AI 700	RDU Temp	The RDU Temperature sensor.

Object ID	Object Name	Function
AO 1	AO1	0-10V Output.
AO 2	AO2	0-10V Output.
AO 3	AO3	0-10V Output.

Object ID	Object Name	Function
AV 1	S1 Offset	Temperature offset to AI 1 (S1).
AV 2	S2 Offset	Temperature offset to AI 2 (S2).
AV 101*1	Cond Dly On	The amount of time between the condensate input returning to normal and output control resuming.
AV 102*1	Cond Dly Off	The amount of time between the condensate input entering alarm and output control stopping.
AV 103	Heat Iso Dly	The delay between the end of heating and the isolation relay opening
AV 104	Cool Iso Dly	The delay between the end of cooling and the isolation relay opening
AV 201*1	R4 Delay Off	The amount of time between an off signal being detected and the Auxiliary relay opening
AV 220*1*2	TPC Heat	The run time for the heating valve
AV 221*1*3	HValve min	The minimum duty for the pwm cycle while controlling, required to pre-heat the valve
AV 222*1*4	Heating %	The current position of the heating valve (Only available for TPC or PWM)
AV 230*1*2	TPC Cool	The run time for the cooling valve
AV 231*1*3	CValve min	The minimum duty for the pwm cycle while controlling required, to pre-heat the valve
AV 232*1*4	Cooling %	The current position of the cooling valve (Only available for TPC or PWM)
AV 300	Set Point	Control set point.
AV 301	Default SP	The default set point used on power up or switch on.
AV 302	Min SP	Minimum user selectable setpoint.
AV 303	Max SP	Maximum user selectable setpoint.
AV 304*1	RSP Reset	The maximum reset to the setpoint
AV 305	Active DB	The current width of the deadband around the setpoint before temperature control becomes active
AV 306	Default DB	The default width of the deadband around the setpoint before temperature control becomes active
AV 307*1	Eco1 DB	The width of the deadband around the setpoint during Eco1 mode
AV 308*1	Eco2 DB	The width of the deadband around the setpoint during Eco2 mode
AV 309	P Band Heat	The width of the proportional band for heating
AV 310	P Band Cool	The width of the proportional band for cooling
AV 311	Int Time	The time taken for the integral component to match the proportional component following a constant step change in error.
AV 312	Slew Time	The time taken for the output to slew from 0-100%
AV 313	Accuracy	The accuracy of the control loop calculation

AV 314	Flush Time	The period for opening the valves to enable flushing
AV 315	Auto Flush	Automatic system flush period
AV 320	Max heating	The maximum heating allowed
AV 321	Min heating	The minimum heating allowed
AV 322	Max cooling	The maximum cooling allowed
AV 323	Min cooling	The minimum cooling allowed
AV 400	High limit	The exhaust temperature limit at which heating is shut off completely
AV 401	High limit PB	The distance from the limit point at which heating modulation begins
AV 402	Low limit	The exhaust temperature limit at which cooling is shut off completely
AV 403	Low limit PB	The distance from the limit point at which cooling modulation begins
AV 500	High Temp SP	The temperature threshold for high limit protection
AV 501	Low Temp SP	The temperature threshold for low limit protection
AV 600	Fan Start Up	The fan will start at full speed if required for this time
AV 601	Fan Overrun	Delays fan off by this time
AV 602	Fan Delay Start	Delays fan start up on heating and/or cooling
AV 603	Occ Override	Time of occupancy override on a button press
AV 604	Occ OR Time	Time remaining for occupancy override
AV 605*1	Autofan Pb Heat	Proportional band for autofan heat
AV 606*1	Offset Heat	Auto fan heat offset
AV 607*1	Autofan Pb Cool	Proportional band for autofan cool
AV 608*1	Offset Cool	Auto fan cool offset
AV 609*1	Fan Slew Time	Autofan slew rate
AV 610	Fan Prove Dly	Delay before the fan prove input causes a fan alarm
AV 700	Ext Temp	The external temperature. Updated via BACnet or a related analog input
AV 701	SP Display	The time that the setpoint will be displayed for
AV 702	Backlight Disp	The time the backlight will remain active after the last button press
AV 706	Maint. Passcode	The password to enter the maintenance menu
AV 707	Set Up Passcode	The password to enter the set-up menu
AV 708	Heat O.R. %	The percentage of heating while in commissioning override mode
AV 709	Cool O.R. %	The percentage of cooling while in commissioning override mode
AV 710	RDU Offset	The offset to be applied to the RDU temperature
AV 800	Upper V	Upper threshold for 'On/Off Ctrl' of the Aux relay when used
AV 801	Lower V	Lower threshold for 'On/Off Ctrl' of the Aux relay when used
AV 802	Ctrl Dly On	An optional delay for the activation of the 'On/Off Ctrl'
AV 803	Ctrl Dly Off	An optional delay for the deactivation of the 'On/Off Ctrl'
AV 1000	Update Period	The time between group updates

Object ID	Object Name	Function
BI 1	In1D	Digital signal present on Input 1
BI 2	In2D	Digital signal present on Input 2
BI 3	In3D	Digital signal present on Input 3
BI 4	In4D	Digital signal present on Input 4
BI 5	In5D	Digital signal present on Input 5
BI 700	Card Status	Whether the card is inserted into the Card RDU or not

Object ID	Object Name	Function
BO 1	DO1	24V Triac output
BO 2	DO2	24V Triac output
BO 3	DO3	24V Triac output
BO 4	Aux Relay	Auxiliary Relay (12A 24VDC 50VAC)

Object ID	Object Name	Function
BV 0	Flash Store	Set True to store current values to flash memory so that they are not lost following a reboot
BV 1	Build Fail	Is set to True if the primary configuration file fails to build. Unit will run on the secondary configuration until the unit is updated

BV 51	VB1	Binary software point 1 – May be assigned to input functions in configuration
BV 52	VB2	Binary software point 2 – May be assigned to input functions in configuration
BV 100*1	Cond Stop Fan	Controls whether the fan should stop during condensate alarm
BV 500*1	Off Default SP	Controls whether the set point resets to the default set point when the unit is turned off.
BV 600*1	Off Selector	Source of 'Off' signal may be a digital input or the RDU buttons
BV 602	Auto Fan Enable	Enables selection of the Auto fan mode
BV 603	Fan Alarm	Is set to True if fan proving is in alarm
BV 604*1	Auto Fan Enable	Autofan control
BV 700	Adjustable SP	Permits user adjustment of the setpoint
BV 701	Temp Units	Units for temperature display
BV 702	Display Temp	Allow the user to see the current temperature or not
BV 703	Disp Ext Temp	Allow the user to see the external temperature or not
BV 704	Display Faults	Display 'Fault' on the screen if the selected temperature sensor is unreliable
BV 705	Disp After Hrs	Displays 'After Hours' during occupancy timed override
BV 706	Flash After Hrs	Whether the 'After Hours' message is flashing or constant
BV 707	Commission Heat	Controls whether the heating outputs are in normal or commissioning override mode
BV 708	Commission Cool	Controls whether the cooling outputs are in normal or commissioning override mode
BV 709	Activate Flush	Calls for System Flush behaviour
BV 800	Polarity	Polarity of the 'On/Off Ctrl' of the aux relay
BV 1000	Transmit All	Set to True to copy the master's set up to all slave units under group control

Object ID	Object Name	Function
MSO 1	3-Stage Relay	Group of 3 mutually exclusive relays (12A 24VDC 50VAC)

Object ID	Object Name	Function
MSV 0	MAC	MAC address of this FCU
MSV 300	System Flush	Determines which outputs will be flushed during System flush behaviour
MSV 301	SP Bias	The position of the SP in the heat/cool dead band
MSV 302	Fan Sim1	Fan status 1
MSV 303	Fan Sim2	Fan status 2
MSV 600	Off Mode	The mode that should operate when the unit is 'Off'.
MSV 601*1	Unocc Mode	The operating mode of the FCU when unoccupied
MSV 602	Active Mode	The current operating mode of the FCU
MSV 603	Active Fan	The current fan setting
MSV 604	Default Fan	The default fan setting
MSV 605	User Fan	The current user fan setting
MSV 606*1	ECO1 Fan	The fan setting to be used during ECO1
MSV 607*1	ECO2 Fan	The fan setting to be used during ECO2
MSV 609	Fan Speeds	The number of fan speeds under manual control
MSV 610*1	Fan Max Man	The voltage required for maximum fan speed under manual control
MSV 611*1	Fan Min Max	The voltage required for minimum fan speed under manual control
MSV 612*1	Fan Max Auto C	The maximum fan voltage under auto control during a cooling cycle
MSV 613*1	Fan Min Auto C	The minimum fan voltage under auto control during a cooling cycle
MSV 614*1	Fan Max Auto H	The maximum fan voltage under auto control during a heating cycle
MSV 615*1	Fan Min Auto H	The minimum fan voltage under auto control during a heating cycle
MSV 618	Heat Cool Cycle	Whether the unit is in Heat, Cool or Off when under manual control
MSV 619	Auto Inc Off	The fan relay and analogue fan run at minimum in the deadband if No selected
MSV 620*1	Heat Cool Default	Whether the unit reverts to Off or the last known state when entering



		occupancy
MSV 621	Fan Start Mode	Determines if start delay is applied to Heat/Cool cycles
MSV 700	Fan Display	The type of indication used to display the current fan
MSV 1000	Group Number	The group number (1-64)
MSV 1001	Group Type	The group type of this device
MSV 1002*1	Full Update	When should the master send a full update to the slave units?

Object ID	Object Name	Function
NC 1	NC1	Notification Class Object with 1 BACnet configurable Recipient List entry.
NC 2	NC2	Notification Class Object with 1 BACnet configurable Recipient List entry.

Object ID	Object Name	Function
File 0	File	Backup and Restore file.

### Object Writable Ranges

If the Objects Present\_Value is writable, it may take a value within the range indicated in the tables below.

Object ID	Object Name	R/W	Note
AI 100	S1	R/W*5	The min/max values, resolution and units of analog inputs are dependant on the input profile selected via the engineer menu system
AI 101	S2	R/W*5	
AI 1	In1A	R/W*5	
AI 2	In2A	R/W*5	
AI 3	In3A	R/W*5	
AI 4	In4A	R/W*5	
AI 5	In5A	R/W*5	
AI 700	RDU Temp	R/W*5	

Object ID	Object Name	R/W	Min Value	Max Value	Resolution	Units
AO 1	AO1	R/W*6	0	10	0.1	V
AO 2	AO2	R/W*6	0	10	0.1	V
AO 3	AO3	R/W*6	0	10	0.1	V

Object ID	Object Name	R/W	Min Value	Max Value	Resolution	Units
AV 1	S1 Offset	R/W	-10	10	0.1	'C
AV 2	S2 Offset	R/W	-10	10	0.1	'C
AV 101*1	Cond Dly On	R/W	0	600	30	Seconds
AV 102*1	Cond Dly Off	R/W	60	600	30	Seconds
AV 103	Heat Iso Dly	R/W	0	900	5	Seconds
AV 104	Cool Iso Dly	R/W	0	900	5	Seconds
AV 201*1	R4 Delay Off	R/W	0	0	60	Seconds
AV 220*1*2	TPC Heat	R/W	0	360	1	Seconds
AV 221*1*3	HValve min	R/W	0	10	0.5	Percent
AV 222*1*4	Heating %	R/O	0	100	1	Percent
AV 230*1*2	TPC Cool	R/W	0	360	1	Seconds
AV 231*1*3	CValve min	R/W	0	10	0.5	Percent
AV 232*1*4	Cooling %	R/O	0	100	1	Percent
AV 300	Set Point	R/W	AV 302	AV 303	0.5	'C
AV 301	Default SP	R/W	AV 302	AV 303	0.5	'C
AV 302	Min SP	R/W	0	AV 303	0.5	'C
AV 303	Max SP	R/W	AV 302	50	0.5	'C

AV 304*1	RSP Reset	R/W	0	10	1	'C
AV 305	Active DB	R/O	0	10	0.1	'C
AV 306	Default DB	R/W	0	10	0.1	'C
AV 307*1	Eco1 DB	R/W	0	10	0.1	'C
AV 308*1	Eco2 DB	R/W	0	10	0.1	'C
AV 309	P Band Heat	R/W	0.5	10	0.1	'C
AV 310	P Band Cool	R/W	0.5	10	0.1	'C
AV 311	Int Time	R/W	0	20	0.5	Minutes
AV 312	Slew Time	R/W	0	300	10	Seconds
AV 313	Accuracy	R/W	0.1	10	0.1	Percent
AV 314	Flush Time	R/W	100	500	50	Seconds
AV315	Auto Flush	R/W	0	240	24	Hours
AV 320	Max heating	R/W	0	100	1	Percent
AV 321	Min heating	R/W	0	100	1	Percent
AV 322	Max cooling	R/W	0	100	1	Percent
AV 323	Min cooling	R/W	0	100	1	Percent
AV 400	High limit	R/W	25	50	0.5	'C
AV 401	High limit PB	R/W	1	10	0.5	'C
AV 402	Low limit	R/W	15	21	0.5	'C
AV 403	Low limit PB	R/W	1	10	0.5	'C
AV 500	High Temp SP	R/W	25	50	1	'C
AV 501	Low Temp SP	R/W	0	25	1	'C
AV 600	Fan Start Up	R/W	0	10	1	Seconds
AV 601	Fan Overrun	R/W	0	15	1	Minutes
AV 602	Fan Delay Start	R/W	0	10	1	Minutes
AV 603	Occ Override	R/W	0	180	10	Minutes
AV 604	Occ OR Time	R/W	0	180	1	Minutes
AV 605*1	Autofan Pb Heat	R/W	0.1	5	0.1	'C
AV 606*1	Offset Heat	R/W	-5	0	0.1	'C
AV 607*1	Autofan Pb Cool	R/W	0.1	5	0.1	'C
AV 608*1	Offset Heat	R/W	0	5	0.1	'C
AV 609*1	Fan Slew Time	R/W	0	300	10	Seconds
AV 610	Fan Prove Dly	R/W	10	300	10	Seconds
AV 700	Ext Temp	R/W	-100	100	0.5	'C
AV 701	SP Display	R/W	0	10	1	Seconds
AV 702	Backlight Disp	R/W	0	100	10	Seconds
AV 706	Maint. Passcode	R/W	0	9999	1	No units
AV 707	Set Up Passcode	R/W	0	9999	1	No units
AV 708	Heat O.R. %	R/W*7	0	100	5	Percent
AV 709	Cool O.R. %	R/W*8	0	100	5	Percent
AV 710	RDU Offset	R/W	-10	10	0.1	'C
AV 800	Upper V	R/W	0	10	0.1	V
AV 801	Lower V	R/W	0	10	0.1	V
AV 802	Ctrl Dly On	R/W	0	600	0	Seconds
AV 803	Ctrl Dly Off	R/W	0	600	10	Seconds
AV 1000	Update Period	R/W	5	300	1	Seconds

Object ID	Object Name	R/W	Inactive Text	Active Text
BI 1	In1D	R/W*5	Inactive	Active
BI 2	In2D	R/W*5	Inactive	Active
BI 3	In3D	R/W*5	Inactive	Active
BI 4	In4D	R/W*5	Inactive	Active
BI 5	In5D	R/W*5	Inactive	Active
BI 700	Card Status	R/W*5	Not Inserted	Inserted

Object ID	Object Name	R/W	Inactive Text	Active Text
-----------	-------------	-----	---------------	-------------



BO 1	DO1	R/W*6	Inactive	Active
BO 2	DO2	R/W*6	Inactive	Active
BO 3	DO3	R/W*6	Inactive	Active
BO 4	Aux Relay	R/W*6	Inactive	Active

Object ID	Object Name	R/W	Inactive State	Active State
BV 0	Flash Store	R/W	FALSE	TRUE
BV 1	Build Fail	R/O	FALSE	TRUE
BV 51	VB1	R/W	Inactive	Active
BV 52	VB2	R/W	Inactive	Active
BV 100*1	Cond Stop Fan	R/W	No	Yes
BV 500*1	Off Default SP	R/W	Disabled	Enabled
BV 600*1	Off Selector	R/W	RDU	Digital
BV 602	Auto Fan Enable	R/W	No	Yes
BV 603	Fan Alarm	R/O	No	Yes
BV 604*1	Auto Fan Enable	R/W	No	Yes
BV 700	Adjustable SP	R/W	No	Yes
BV 701	Temp Units	R/W	Deg F	Deg C
BV 702	Display Temp	R/W	No	Yes
BV 703	Disp Ext Temp	R/W	No	Yes
BV 704	Display Faults	R/W	No	Yes
BV 705	Disp After Hrs	R/W	No	Yes
BV 706	Flash After Hrs	R/W	No	Yes
BV 707	Commission Heat	R/W	No	Yes
BV 708	Commission Cool	R/W	No	Yes
BV 709	Activate Flush	R/W	Inactive	Start
BV 800	Polarity	R/W	Normal	Reverse
BV 1000	Transmit All	R/W	FALSE	TRUE

Object ID	Object Name	R/W	States
MSO 1	3-Stage Relay	R/W*4	0 / 1 / 2 / 3

Object ID	Object Name	R/W	States
MSV 0	MAC	R/O	0-127
MSV 300	System Flush	R/W	Heat / Cool / Both
MSV 301	SP Bias	R/W	Heat / Cool / Both
MSV 302	Fan Sim1	R/W	No Flt / Flt / Pulse Flt S / Pulse Flt L
MSV 303	Fan Sim2	R/W	No Flt / Flt / Pulse Flt S / Pulse Flt L
MSV 600	Off Mode	R/W	Off / Low Prot / High Prot / Both Prot / Eco1 / Eco2
MSV 601*1	Unocc Mode	R/W	Normal / Eco1 / Eco2 / Off
MSV 602	Active Mode	R/W*9	Off / Normal / Low Prot / High Prot / Window / Eco1 / Eco2 / Occ OR
MSV 603	Active Fan	R/O	Auto / 0 / 1 / 2 / 3 / 4 / 5 / 6 / 7 / 8 / 9 / 10
MSV 604	Default Fan	R/W*10	Auto / 0 / 1 / 2 / 3 / 4 / 5 / 6 / 7 / 8 / 9 / 10
MSV 605	User Fan	R/W*10	Auto / 0 / 1 / 2 / 3 / 4 / 5 / 6 / 7 / 8 / 9 / 10
MSV 606	ECO1 Fan	R/W*10	Auto / 0 / 1 / 2 / 3 / 4 / 5 / 6 / 7 / 8 / 9 / 10
MSV 607	ECO2 Fan	R/W*10	Auto / 0 / 1 / 2 / 3 / 4 / 5 / 6 / 7 / 8 / 9 / 10
MSV 609	Fan Speeds	R/W	1 / 2 / 3 / 4 / 5 / 6 / 7 / 8 / 9 / 10
MSV 610*1	Fan Max Man	R/W	0-10 in 0.1 steps
MSV 611*1	Fan Min Max	R/W	0-10 in 0.1 steps
MSV 612*1	Fan Max Auto C	R/W	0-10 in 0.1 steps
MSV 613*1	Fan Min Auto C	R/W	0-10 in 0.1 steps
MSV 614*1	Fan Max	R/W	0-10 in 0.1 steps

	Auto H		
MSV 615*1	Fan Min Auto H	R/W	0-10 in 0.1 steps
MSV 618	Heat Cool Cycle	R/W	Heat / Off / Cool
MSV 619	Auto Inc Off	R/W	Yes/No
MSV 620*1	Heat Cool Default	R/W	Off / Last
MSV 621	Fan Start Mode	R/W	None/Heat/Cool/Both
MSV 700	Fan Display	R/W	Numbers / Text / Graphics
MSV 1000	Group Number	R/W	1-64
MSV 1001	Group Type	R/W	None / Slave / Master
MSV 1002*1	Full Update	R/W	Never / Reboot / Once

Notes:

\*1 Object availability subject to configuration and associated object values.

\*2 Depending upon configuration options this object will have one of the following sets of data

Name	Description
TPC Heating	The run time for the heating valve
TPC Cooling	The run time for the cooling valve
TPC Comb HC	The run time for the combined heating and cooling valve
TPC Comb CH	The run time for the combined cooling and heating valve
PWM Heating	The period of the PWM cycle
PWM Cooling	The period of the PWM cycle
PWM Comb HC	The period of the PWM cycle
PWM Comb CH	The period of the PWM cycle

\*3 Depending upon configuration options this object will have one of the following sets of data

Name	Description
HValve min	The minimum duty for the pwm cycle while controlling required to pre-heat the valve
CValve min	The minimum duty for the pwm cycle while controlling required to pre-heat the valve
HCVValve min	The minimum duty for the pwm cycle while controlling required to pre-heat the valve
CHValve min	The minimum duty for the pwm cycle while controlling required to pre-heat the valve

\*4 Depending upon configuration options this object will have one of the following sets of data

Name	Description
Heating %	The current position of the heating valve
Cooling %	The current position of the cooling valve
Comb HC %	The current position of the combined heating and cooling valve
Comb CH %	The current position of the combined cooling and heating valve

\*5 Present\_Value only writable when Out\_Of\_Service is True

\*6 Present\_Value can be written with a higher priority than controllers priority level 15.

\*7 Present\_Value only writable dependent on BV707 (Commision Heat) setting

\*8 Present\_Value only writable dependent on BV708 (Commision Cool) setting

\*9 Present\_Value state writable dependent on BV600 (Off Selector) setting

\*10 Present\_Value state writeable dependent on MSV609 (Fan speeds) and BV602 (Auto Fan Enable) settings

## BACnet Protocol Implementation Conformance Statement

**Date:** Oct 2019  
**Vendor Name:** Titan Products Ltd.  
**Product Name:**  
**Product Model Number:** FCU403 TP1193E  
**Firmware Revision:** 4.9  
**BACnet Protocol Revision:** 3  
**Applications Software Version:** FCU403 TRX (and derivatives)

FCU4

### BACnet Standardized Device Profile (Annex L):

- BACnet Operator Workstation (B-OWS)
- BACnet Building Controller (B-BC)
- BACnet Advanced Application Controller (B-AAC)
- BACnet Application Specific Controller (B-ASC)
- BACnet Smart Sensor (B-SS)
- BACnet Smart Actuator (B-SA)

### List all BACnet Interoperability Building Blocks Supported (Annex K):

DM-DDB-A/B	Device Management – Dynamic Device Binding – A/B
DM-DOB-B	Device Management – Dynamic Object Binding – B
DM-DCC-B	Device Management – Device Communications Control – B
DM-PT-A/B	Device Management – Private Transfer – A/B
DM-TS-B	Device Management – Time Synchronization – B
DM-RD-B	Device Management – Reinitialize Device – B
DM-BR-B	Device Management – Backup and Restore – B
DS-RP-B	Data Sharing – Read Property – B
DS-RPM-B	Data Sharing – Read Property Multiple – B
DS-WP-B	Data Sharing – Write Property – B
DS-WPM-B	Data Sharing – Write Property Multiple – B
DS-COV-B	Data Sharing – Change of Value – B
AE-N-I-B	Alarm and Event Notification Internal – B
AE-ACK-B	Alarm and Event ACK – B

### Segmentation Capability:

- Segmented requests supported                      Window Size
- Segmented responses supported                      Window Size

**Standard Object Types Supported:**

Object Type	Property	Optional	Writable	Range Restriction	
<b>Device</b>	Object_Identifier				
	Object_Name				
	Object_Type				
	System_Status				
	Vendor_Name				
	Vendor_Identifier				
	Model_Name				
	Firmware_Revision				
	Application_Software_Version				
	Location	✓			
	Description	✓			
	Protocol_Version				
	Protocol_Revision				
	Protocol_Services_Supported				
	Protocol_Object_Types_Supported				
	Object_List				
	Max_APDU_Length_Accepted				
	Segmentation_Supported				
	Local_Time	✓			
	Local_Date	✓			
	APDU_Timeout			✓	0 to 60000ms
	Number_Of_APDU_Retries			✓	1 to 10
	Max_Masters	✓			
	Max_Info_Frames	✓			
	Device_Address_Binding				
	Database_Revision				
	Configuration_Files	✓			
	Last_Restore_Time	✓			
	Backup_Failure_Timeout	✓			
	Active_COV_Subscriptions	✓			
<b>Analog Input</b>	Object_Identifier				
	Object_Name				
	Object_Type				
	Present_Value		✓ <sup>1</sup>	✓ (Instance dependent)	
	Description	✓			
	Device_Type	✓			
	Status_Flags				
	Event_State				
	Reliability	✓			
	Out_Of_Service		✓		
	Units				
	Min_Pres_Value	✓			
	Max_Pres_Value	✓			
	Resolution	✓			
	Time_Delay	✓	✓	0 to 60000 seconds	
	Notification_Class	✓	✓	NC1, NC2	
	High_Limit	✓	✓		
Low_Limit	✓	✓			
Deadband	✓	✓			
Limit_Enable	✓	✓			

	Event_Enable	✓	✓	
	Acked_Transitions	✓		
	Notify_Type	✓	✓	
	Event_Time_Stamps	✓		
	COV_Increment	✓		

Object Type	Property	Optional	Writable	Range Restriction
<b>Analog Output</b>	Object_Identifier			
	Object_Name			
	Object_Type			
	Present_Value		✓	✓ (Instance dependent)
	Description	✓		
	Device_Type	✓		
	Status_Flags			
	Event_State			
	Out_Of_Service			
	Units			
	Min_Pres_Value	✓		
	Max_Pres_Value	✓		
	Resolution	✓		
	Priority_Array			
	Relinquish_Default			
	Time_Delay	✓	✓	0 to 60000 seconds
	Notification_Class	✓	✓	NC1, NC2
	High_Limit	✓	✓	
	Low_Limit	✓	✓	
	Deadband	✓	✓	
Limit_Enable	✓	✓		
Event_Enable	✓	✓		
Acked_Transitions	✓			
Notify_Type	✓	✓		
Event_Time_Stamps	✓			
COV_Increment	✓			
<b>Analog Value</b>	Object_Identifier			
	Object_Name			
	Object_Type			
	Present_Value		✓	✓ (Instance dependent)
	Description	✓		
	Status_Flags			
	Event_State			
	Out_Of_Service			
	Units			
	Time_Delay	✓	✓	0 to 60000 seconds
	Notification_Class	✓	✓	NC1, NC2
	High_Limit	✓	✓	
	Low_Limit	✓	✓	
	Deadband	✓	✓	
	Limit_Enable	✓	✓	
	Event_Enable	✓	✓	
	Acked_Transitions	✓		
	Notify_Type	✓	✓	
	Event_Time_Stamps	✓		
	COV_Increment	✓		

Object Type	Property	Optional	Writable	Range Restriction
<b>Binary Output</b>	Object_Identifier			
	Object_Name			
	Object_Type			
	Present_Value		✓	
	Description	✓		
	Device_Type	✓		
	Status_Flags			
	Event_State			
	Out_Of_Service			
	Polarity		✓	
	Inactive_Text	✓		
	Active_Text	✓		
	Change_Of_State_Time	✓		
	Change_Of_State_Count	✓	✓	0
	Time_Of_State_Reset	✓		
	Priority_Array			
	Relinquish_Default			
<b>Binary Input</b>	Object_Identifier			
	Object_Name			
	Object_Type			
	Present_Value		✓ <sup>1</sup>	
	Description	✓		
	Device_Type	✓		
	Status_Flags			
	Event_State			
	Reliability	✓		
	Out_Of_Service		✓	
	Polarity		✓	
	Inactive_Text	✓		
	Active_Text	✓		
	Change_Of_State_Time	✓		
	Change_Of_State_Count	✓	✓	0
	Time_Of_State_Count_Reset	✓		
	Time_Delay	✓	✓	0 to 60000 seconds
	Notification_Class	✓	✓	NC1, NC2
	Alarm_Value	✓	✓	
Event_Enable	✓	✓		
Acked_Transitions	✓			
Notify_Type	✓	✓		
Event_Time_Stamps	✓			
<b>Binary Value</b>	Object_Identifier			
	Object_Name			
	Object_Type			
	Present_Value		✓	
	Description	✓		
	Status_Flags			
	Event_State			
	Out_Of_Service			
	Inactive_Text	✓		
	Active_Text	✓		
Time_Delay	✓	✓	0 to 60000 seconds	
Notification_Class	✓	✓	NC1, NC2	



	Alarm_Value	✓	✓	
	Event_Enable	✓	✓	
	Acked_Transitions	✓		
	Notify_Type	✓	✓	
	Event_Time_Stamps	✓		
<b>Multi State Output</b>	Object_Identifier			
	Object_Name			
	Object_Type			
	Present_Value		✓	✓ (Instance dependent)
	Description	✓		
	Status_Flags			
	Event_State			
	Out_Of_Service			
	Number_Of_States			
	State_Text	✓		
	Priority_Array			
	Relinquish_Default			
<b>Multi-state Value</b>	Object_Identifier			
	Object_Name			
	Object_Type			
	Present_Value		✓	✓ (Instance dependent)
	Description	✓		
	Status_Flags			
	Event_State			
	Out_Of_Service			
	Number_Of_States			
	State_Text	✓		
<b>Notification Class</b>	Object_Identifier			
	Object_Name			
	Object_Type			
	Description	✓		
	Notification_Class			
	Priority		✓	
	Ack_Required		✓	
	Recipient_List		✓	x1 BACnet Recipient <sup>2</sup>
<b>File</b>	Object_Identifier			
	Object_Name			
	Object_Type			
	Description	✓		
	File_Type			
	File_Size		✓	0
	Modification_Date			
	Archive			
	Read_Only			
	File_Access_Method			

<sup>1</sup> Present\_Value only writable when Out\_Of\_Service True

<sup>2</sup> Dynamic Device Binding when BACnetRecipient ::= CHOICE { device [0] BACnetObjectIdentifier }

### Data Link Layer Options:

- BACnet IP, (Annex J)
- BACnet IP, (Annex J), Foreign Device
- ISO 8802-3, Ethernet (Clause 7)
- ANSI/ATA 878.1, 2.5 Mb. ARCNET (Clause 8)
- ANSI/ATA 878.1, RS-485 ARCNET (Clause 8), baud rate(s) \_\_\_\_\_
- MS/TP master (Clause 9), baud rate(s): 9600, 19200, 38400, 76800
- MS/TP slave (Clause 9), baud rate(s):
- Point-To-Point, EIA 232 (Clause 10), baud rate(s):
- Point-To-Point, modem, (Clause 10), baud rate(s):
- LonTalk, (Clause 11), medium: \_\_\_\_\_
- Other:

### Device Address Binding:

Is static device binding supported? (This is currently necessary for two-way communication with MS/TP slaves and certain other devices.)  Yes  No

### Networking Options:

- Router, Clause 6 - List all routing configurations, e.g., ARCNET-Ethernet, Ethernet-MS/TP, etc.
  - Annex H, BACnet Tunneling Router over IP
  - BACnet/IP Broadcast Management Device (BBMD)
- Does the BBMD support registrations by Foreign Devices?  Yes  No

### Character Sets Supported:

Indicating support for multiple character sets does not imply that they can all be supported simultaneously.

- |   |  |                                     |
|---|--|-------------------------------------|
| <input checked="" type="checkbox"/> ANSI X3.4 | <input type="checkbox"/> IBM <sup>™</sup> /Microsoft <sup>™</sup> DBCS | <input type="checkbox"/> ISO 8859-1 |
| <input type="checkbox"/> ISO 10646 (UCS-2)    | <input type="checkbox"/> ISO 10646 (UCS-4)                             | <input type="checkbox"/> JIS C 6226 |