



Differential pressure measurement via damper blade



Compact controller with display

VAV terminal units

TVE

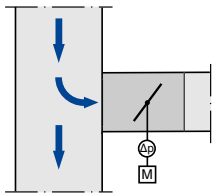
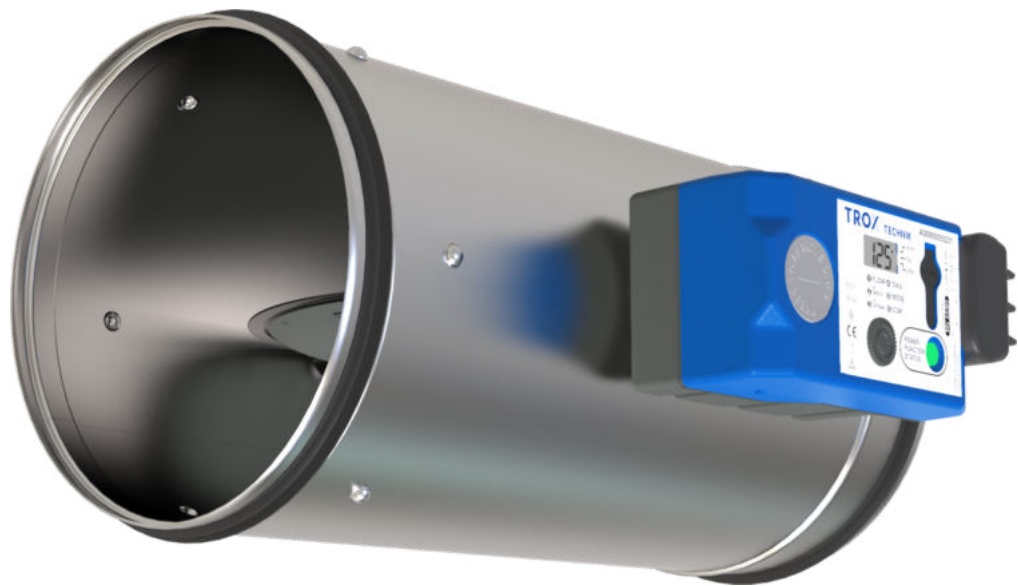

For all upstream conditions

Compact solution for low airflow velocities

Circular air terminal units for variable air volume systems with low airflow velocities, suitable even with unfavourable upstream conditions

- Effective pressure measurement not with a tube, but by means of the damper blade
- Effective pressure transmission through effective pressure channel in the shaft
- Terminals with protective cover, no junction box required
- Any airflow direction if dynamic transducer is used
- Suitable for airflow velocities of 0.5 – 13 m/s
- Compact dimensions allow for use in restricted spaces
- Plug-and-play solution in conjunction with X-AIRCONTROL room control
- Exact measurement even with low airflow velocities
- Any installation orientation even with static transducer
- Closed blade air leakage to EN 1751, at least class 3
- Casing air leakage to EN 1751, class C
- Volume flow rate range 1:25

Optional equipment and accessories

- Acoustic cladding for the reduction of case-radiated noise
- Secondary silencer CA (for Germany and Switzerland), CAH (for EMEA) or CF for the reduction of air-regenerated noise
- Hot water heat exchanger WL and electric air heater EL for reheating the airflow



Tested to VDI 6022

General information	2	Order code	10
Function	4	Variants	12
Technical data	5	Dimensions and weight	15
Quick sizing	5	Product details	20
Specification text	9	Nomenclature	22

General information

Application

- Circular VAV terminal units for use in ventilation and air conditioning systems
- For virtually all control, inductor and shut-off tasks in the supply air or extract air area
- Also for unfavourable upstream conditions at low airflow velocities
- Closed-loop volume flow control using an external power supply
- For variable or constant volume flow systems
- Shut-off via override control by others

Special features

- High effective pressure signal at a small angle of attack
- Factory set-up or programming and aerodynamic function testing
- Volume flow rate can be measured and subsequently adjusted on site; additional adjustment tool may be necessary (depending on the variant of the control component)
- Effective pressure monitoring tubeless via damper blade
- Effective pressure transmission through effective pressure channel in shaft
- Any direction of flow with dynamic transducer
- Any installation orientation, even with static transducers
- Suitable for airflow velocity of 0.5 - 13 m/s
- Compact dimensions for use in confined ceiling areas

Nominal sizes

- 100, 125, 160, 200, 250, 315, 400

Variants

- TVE: VAV terminal unit
- TVE-D: VAV terminal unit with acoustic cladding
- TVE-FL: VAV terminal unit with flanges on both ends
- TVE-D-FL: VAV terminal unit with acoustic cladding and flanges on both ends
- Units with acoustic cladding and/or a secondary silencer CA (for Germany and Switzerland), CH (for EMEA) or CF for demanding acoustic requirements

Construction

- Galvanised sheet steel
- P1: Powder-coated, silver grey (RAL 7001)
- A2: Stainless steel

Parts and characteristics

- Ready-to-commission unit which consists of mechanical parts and control components.
- Damper blade with integrated measuring unit
- Shaft with effective pressure channel for measured value transmission
- Factory-assembled control components complete with wiring
- Aerodynamic functional testing on a special test rig prior to shipping of each unit
- Set-up data is given on a label or volume flow rate scale affixed to the unit
- High control accuracy, even in unfavourable upstream conditions

Attachments

- EASY controller: Compact unit consisting of controller with potentiometers, effective pressure transducer and actuator
- Compact controller: Compact unit consisting of controller with potentiometers, effective pressure transducer and actuator
- Compact controller Modbus: Variant with Modbus RTU interface; plug-and-play solution in conjunction with X-AIRCONTROL room control

Accessories

- G2: Matching flanges for both ends
- D2: Double lip seals on both ends (factory fitted)

Useful additions

- Secondary silencer CA (for Germany and Switzerland), CAH (for EMEA) or CF
- Heat exchanger WL
- Electric air heater EL

Construction features

- Circular casing
- Spigot suitable for circular ducts to EN 1506 or EN 13180
- Spigots with groove for seal
- Position of the damper blade indicated externally at position indicator
- TVE-FL: Flanges to EN 12220
- Control component can be replaced

Materials and surfaces

Galvanised sheet steel

- Casing made of galvanised sheet steel
- Damper blade, effective pressure sensor and shaft made of plastic, PA6, UL94, flame retardant (V-0)
- Damper blade seal made of plastic, TPU, antimicrobial
- Plastic plain bearings

Powder-coated construction (P1)

- Casing made of galvanised sheet steel, surface powder coated, silver grey (RAL 7001)
- Damper blade, effective pressure sensor and shaft made of plastic, PA6, UL94, flame retardant (V-0)
- Damper blade seal made of plastic, TPU, antimicrobial
- Plastic plain bearings

Stainless steel construction (A2)

- Casing made of stainless steel 1.4301
- Damper blade, effective pressure sensor and shaft made of plastic, PA6, UL94, flame retardant (V-0)
- Damper blade seal made of plastic, TPU, antimicrobial
- Plastic plain bearings

Acoustic cladding

- Variant with acoustic cladding (-D)
- Acoustic cladding made of galvanised sheet steel
- PE ring for the insulation of structure-borne noise
- Lining is mineral wool

Mineral wool

- To EN 13501, fire rating Class A1, non-combustible
- RAL quality mark RAL-GZ 388
- Non-hazardous to health thanks to being highly biosoluble in accordance with the Ordinance on Hazardous Substances and Note Q of the European Directive (EC) No. 1272/2008

Standards and guidelines

Fulfils the hygiene requirements of

- EN 16798, Part 3
- VDI 6022, Sheet 1
- DIN 1946, Part 4
- For other applicable standards and guidelines refer to the hygiene certificate

Casing leakage

- EN 1751, Class C

Closed blade air leakage:

NS 100 – 160

- EN 1751, Class 3
- Meets the general requirements of DIN 1946, part 4, with regard to the acceptable closed blade air leakage

NS 200 – 400

- EN 1751, Class 4
- Meets the increased requirements of DIN 1946, part 4, with regard to the acceptable closed blade air leakage

Maintenance

- Maintenance-free as construction and materials are not subject to wear

Function

Functional description

The control damper blade works as an actuator and as an effective pressure sensor. Through the effective pressure channel in the shaft, the detected effective pressure reaches the transducer (static or dynamic), where it is converted into an

electrical signal and compared with the setpoint value. If there is a control deviation, the integrated actuator changes the position of the control damper blade. As a result, the volume flow rate is maintained at a constant level in close tolerances over the entire differential pressure range.

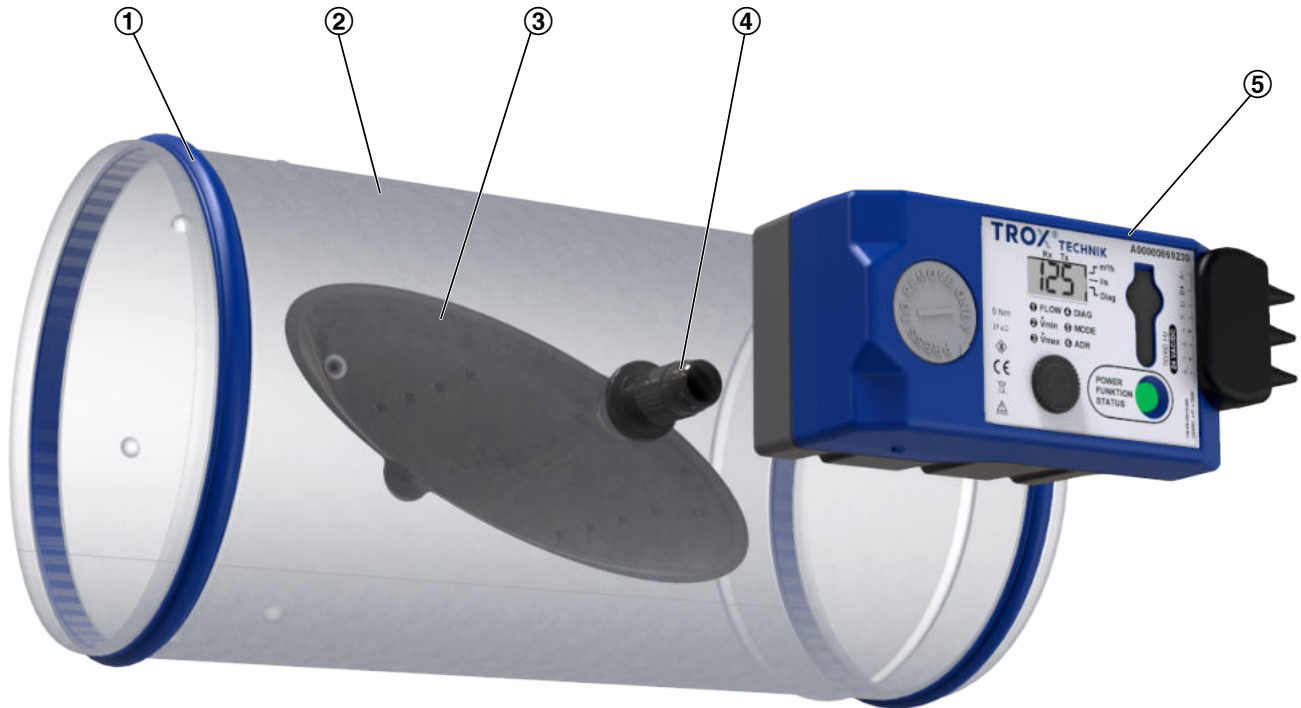

- ① Double lip seal
- ② Casing
- ③ Damper blade including effective pressure sensor
- ④ Shaft with effective pressure channel
- ⑤ Electronic volume flow controller

Technical data

Nominal sizes	100 – 400 mm
Volume flow rate range	4 - 1388 l/s or 14 - 5000 m ³ /h
Volume flow rate control range (unit with dynamic effective pressure measurement)	Approx. 4 – 100 % of the nominal volume flow rate
Minimum differential pressure	Up to 50 Pa (without circular silencer)
Maximum differential pressure	Control component with dynamic transducer: 900 Pa, control component with static transducer: 600 Pa
Operating temperature	10 to 50 °C

Quick sizing

Quick sizing tables provide a good overview of the minimum differential pressures, the volume flow rate accuracy and the room sound pressure levels that can be expected. Intermediate values may be achieved by interpolation. The sound power levels for calculating the sound pressure levels were measured in the TROX laboratory according to DIN EN ISO 5135 - see "Basic information and nomenclature". Precise results and spectral data for all control components can be calculated with our Easy Product Finder design program. The first selection criteria for the nominal size are the actual volume flow rates q_{vmin} and q_{vmax} .

Volume flow rate ranges and minimum differential pressure values

The minimum differential pressure of VAV terminal units is an important factor in designing the ductwork and in rating the fan including speed control. Sufficient static differential pressure ($\Delta_{pstat,min}$) must be ensured for all operating conditions and for all controllers. The measurement points for fan speed control must be selected accordingly. The volume flow rates given for VAV terminal units depend on the nominal size and on the control component (attachment) that is installed.

Volume flow rate ranges and minimum differential pressure values

Controller for dynamic and static pressure measurements

Attachment: Easy, XB0, XM0, XM0-J6, XS0, XS0-J6

Nominal size	qv [l/s]	qv [m³/h]	Δpstmin [Pa]				Δqv [±%]
			①	②	③	④	
100	4	14	1	1	1	1	18
100	35	127	6	9	11	13	7
100	67	241	22	29	37	44	5
100	98	354	46	63	79	95	5
125	6	21	1	1	1	1	19
125	58	207	6	7	9	11	7
125	109	393	19	25	31	37	5
125	160	579	41	54	68	81	5
160	10	35	1	1	1	1	18
160	93	333	7	8	9	10	7
160	175	631	22	26	30	34	5
160	258	929	47	56	65	74	5
200	16	55	1	1	1	1	18
200	150	541	6	6	7	8	7
200	285	1027	19	22	25	29	5
200	420	1513	40	47	54	61	5
250	25	87	1	1	1	1	18
250	228	822	5	6	7	7	7
250	433	1558	17	20	22	25	5
250	636	2293	37	42	47	53	5
315	52	186	1	1	1	1	16
315	359	1291	7	8	8	9	7
315	665	2395	23	25	26	28	6
315	972	3500	49	53	56	59	5
400	117	420	1	1	1	1	14
400	541	1947	8	8	8	8	7
400	965	3473	23	24	25	26	6
400	1388	5000	47	49	51	53	5

① Basic unit

② Basic unit with circular silencer CF, insulation thickness 50 mm, length 500 mm

③ Basic unit with circular silencer CF, insulation thickness 50 mm, length 1000 mm

④ Basic unit with circular silencer CF, insulation thickness 50 mm, length 1500 mm

Quick sizing table for sound pressure levels

The quick sizing tables are based on generally accepted attenuation levels. If the sound pressure level exceeds the required level, a larger air terminal unit and/or a silencer or acoustic cladding is required. For more information on the acoustic data, see basic information and nomenclature.

Quick sizing table for air-regenerated noise L_{PA}

Controller including silencer

Nominal size	qv [l/s]	qv [m³/h]	$\Delta p_{st} = 150 \text{ Pa}$				$\Delta p_{st} = 500 \text{ Pa}$			
			①	②	③	④	①	②	③	④
100	4	14	32	< 15	< 15	< 15	42	17	< 15	< 15
100	35	127	46	32	28	24	56	40	34	31
100	67	241	51	37	33	29	60	47	42	38
100	98	354	55	37	32	30	64	52	47	44
125	6	21	37	15	< 15	< 15	48	26	16	< 15
125	58	207	48	34	28	25	59	42	35	31
125	109	393	52	39	34	31	62	47	41	37
125	160	579	56	41	37	34	63	49	44	40
160	10	35	42	24	15	< 15	54	38	29	22
160	93	333	45	33	28	25	58	43	36	31
160	175	631	50	38	34	31	58	44	38	34
160	258	929	53	40	35	33	57	44	39	36
200	16	55	33	20	< 15	< 15	44	32	26	21
200	150	541	46	36	31	28	57	47	42	39
200	285	1027	49	38	34	32	58	49	44	41
200	420	1513	53	43	40	38	58	49	45	42
250	25	87	40	29	22	17	52	42	36	31
250	228	822	46	37	32	29	58	50	45	41
250	433	1558	47	39	34	32	57	50	45	41
250	636	2293	52	45	41	38	57	50	45	42
315	52	186	42	34	28	24	54	47	42	38
315	359	1291	43	36	31	28	55	48	44	41
315	665	2395	45	38	33	31	54	48	44	41
315	972	3500	48	41	37	34	54	47	44	41
400	117	420	47	42	37	32	57	53	48	43
400	541	1947	45	40	35	31	55	50	46	43
400	541	1947	44	38	34	31	54	49	46	42
400	1388	5000	48	42	38	35	54	49	45	42

Air-regenerated noise L_{PA} [dB(A)] at static differential pressure Δp_{st} 150 or 500 Pa

- ① Basic unit
- ② Basic unit with circular silencer CF, insulation thickness 50 mm, length 500 mm
- ③ Basic unit with circular silencer CF, insulation thickness 50 mm, length 1000 mm
- ④ Basic unit with circular silencer CF, insulation thickness 50 mm, length 1500 mm

Quick sizing table for case-radiated noise L_{PA}

Controller including acoustic cladding

Nominal size	qv [l/s]	qv [m³/h]	$\Delta p_{st} = 150 \text{ Pa}$		$\Delta p_{st} = 500 \text{ Pa}$	
			①	②	①	②
100	4	14	15	< 15	25	< 15
100	35	127	29	18	39	28
100	67	241	34	23	43	32
100	98	354	37	26	48	37
125	6	21	20	< 15	31	20
125	58	207	31	20	42	31
125	109	393	35	24	45	34
125	160	579	40	29	47	36
160	10	35	22	15	34	27
160	93	333	25	18	38	31
160	175	631	31	24	39	32
160	258	929	36	29	40	33
200	16	55	< 15	< 15	24	< 15
200	150	541	26	< 15	37	22
200	285	1027	32	17	41	26
200	420	1513	38	23	43	28
250	25	87	24	< 15	36	21
250	228	822	32	17	44	29
250	433	1558	36	21	46	31
250	636	2293	43	28	48	33
315	52	186	27	< 15	38	21
315	359	1291	32	15	44	27
315	665	2395	37	19	46	28
315	972	3500	41	24	47	30
400	117	420	32	16	42	26
400	541	1947	36	20	46	30
400	965	3473	37	21	48	32
400	1388	5000	43	27	49	33

Case-radiated noise L_{PA} [dB(A)] at static differential pressure Δp_{st} 150 or 500 Pa

① Basic unit

② Basic unit with acoustic cladding

Note:

Information on case-radiated noise for combinations of basic unit and optional acoustic cladding and secondary silencer can be found in the Easy Product Finder design program.

Specification text

This specification text describes the general properties of the product. Texts for variants can be generated with our Easy Product Finder design program.

Specification text

Circular VAV terminal units for variable and constant air volume systems, suitable for supply or extract air, available in 7 nominal sizes. High control accuracy even in case of unfavourable upstream conditions. Control range at least 1:25. The effective pressure is captured by means of the damper blade, which is controlled accordingly. The effective pressure is transmitted to the control component via a channel in the shaft (no measuring tubes required). Closed blade air leakage to EN 1751: at least class 3, from NS 200: class 4. Casing air leakage to EN 1751, class C. Ready-to-commission unit which consists of the mechanical parts and the factory mounted electronic control component. Position of the damper blade indicated externally at the control component. The damper blade is factory set to open position, which allows a ventilation airflow even without control. Meets the hygiene requirements of EN 16798, Part 3, of VDI 6022, Sheet 1, and of DIN 1946, Part 4.

Special features

- High effective pressure signal at a small angle of attack
- Factory set-up or programming and aerodynamic function testing
- Volume flow rate can be measured and subsequently adjusted on site; additional adjustment tool may be necessary (depending on the variant of the control component)
- Effective pressure monitoring tubeless via damper blade
- Effective pressure transmission through effective pressure channel in shaft
- Any direction of flow with dynamic transducer
- Any installation orientation, even with static transducers
- Suitable for airflow velocity of 0.5 - 13 m/s
- Compact dimensions for use in confined ceiling areas

Materials and surfaces

- Casing made of galvanised sheet steel
- Damper blade and shaft made of plastic, PA6, UL94-V0
- Damper blade seal made of plastic, TPU, micro bacterial resistant
- Plastic plain bearings

Equivalence criteria

- Declaration of hygiene conformity in accordance with VDI 6022, Sheet 1 (01/2018), ÖNORM H 6020 (03/2015) and ÖNORM H 6021 (08/2016)

- Independent of the airflow direction – flow in both directions
- Suitable for airflow velocity of 0.5 - 13 m/s
- No inflow lengths required (after T-piece also)
- Fulfils the hygiene requirements of EN 16798 Part 3, VDI 6022 Sheet 1, DIN 1946 Part 4.
- Setting the volume flow rates without adjustment device via V_{\min} and V_{\max} potentiometer
- Electrical connections with screw terminals, no additional terminal boxes required
- Acoustic data measured to ÖNORM EN ISO 5135
- Maximum system deviation 5 % at $q_{v\max}$, without inflow length

Connection

- Spigot with groove for lip seal, suitable for connecting ducts according to EN 1506 or EN 13180

Technical data

- Minimum differential pressure: up to 50 Pa (without circular silencer)

Maximum differential pressure

- Control component with dynamic transducer: 900 Pa
- Control component with static transducer: 600 Pa

Specification text for attachment

Variable volume flow control with electronic Easy controller to connect an external control signal; actual value signal can be integrated into the central BMS.

- Supply voltage 24 V AC/DC
- Signal voltages 0 – 10 V DC
- Possible override controls with external switches using volt-free contacts: CLOSED, OPEN, $q_{v\min}$ and $q_{v\max}$
- Potentiometers with percentage scales to set the volume flow rates $q_{v\min}$ and $q_{v\max}$
- The actual value signal relates to the nominal volume flow rate such that commissioning and subsequent adjustment are simplified
- Volume flow rate control range: approx. 4 – 100 % of the nominal volume flow rate
- Indicator light that is highly visible from the outside for signalling the various operating conditions

Electrical connections with screw terminals. Double terminals for looping the supply voltage, i.e. for the simple connection of voltage transmission to the next controller.

Order code

Order code for volume flow control (with Easy attachment)

TVE – D / 100 / D2 / Easy
 | | | | |
 1 2 5 6 7

1 Type

TVE VAV terminal unit

2 Acoustic cladding

No entry: none

D With acoustic cladding

5 Nominal size [mm]

100, 125, 160, 200, 250, 315, 400

Order example: TVE-D/200/D2/Easy

Type	TVE
Acoustic cladding	With acoustic cladding
Nominal size [mm]	200
Accessories	Double lip seal both ends
Attachments (control components)	Volume flow controller, dynamic, analogue interface, setting of q_{\min} and q_{\max} with potentiometers (by others)

6 Accessories

No entry: without accessories

D2 Double lip seal both ends

7 Attachments (control components)

Easy Volume flow controller, dynamic, analogue interface, setting of q_{\min} and q_{\max} with potentiometers (by others)

Order code for volume flow control (with VARYCONTROL attachment)

TVE – D – P1 – FL / 100 / G2 / XB0 / V 0 / 200 – 900 [m³/h]
 | | | | | | | | | |
 1 2 3 4 5 6 7 8 9 10

1 Type

TVE VAV terminal unit

2 Acoustic cladding

No entry required: None

D With acoustic cladding

3 Material

No entry required: Galvanised sheet steel

P1 Duct powder-coated, RAL 7001, silver grey

A2 Duct made of stainless steel

4 Duct connection

No entry required: Attachment for duct in accordance with EN 1506; with groove for optional seal

FL Flanges on both ends

5 Nominal size [mm]

100, 125, 160, 200, 250, 315, 400

6 Accessories

No entry required: None

D2 Double lip seal both sides (only with insertion with groove)

G2 Matching flange to each flange (only with FL)

7 Attachment (control component)

XB0 Volume flow controller, dynamic, analogue interface

XM0 Volume flow controller, analogue interface and Modbus RTU, display

XM0-J6 Volume flow controller, Modbus RTU interface, display, RJ12 bush (for X-AIRCONTROL)

XS0 Volume flow controller, static, interface analogue and Modbus RTU, display

XS0-J6 Volume flow controller, static, Modbus RTU interface, display, RJ12 bush (for X-AIRCONTROL)

8 Operating mode

V Variable, setpoint value range (not for XM0-J6, XS0-J6)

F Constant value, a setpoint value (not for XM0-J6, XS0-J6)

M Modbus RTU interface (only selectable with XM0, XS0 attachment, mandatory for XM0-J6, XS0-J6)

9 Signal voltage range (only with operating mode V, F)

0 0 – 10 V DC

2 2 – 10 V DC

10 Operating values for factory setting

Volume flow rates in [m³/h or l/s] see unit

q_{const} (in operating mode F)

$q_{\text{vmin}} - q_{\text{vmax}}$ (in operating mode V, M)

11 Unit

m³/h Volume flow rates in m³/h

l/s Volume flow rates in l/s

Order example: TVE-D-P1-FL/100/G2/XB0/V0/200-900 [m³/h]

Type	TVE
Acoustic cladding	With acoustic cladding
Material	Duct powder-coated RAL 7001, silver grey
Duct connection	Flanges on both ends
Nominal size [mm]	100
Accessories	Matching flanges both ends (only with FL)
Attachments (control components)	Volume flow controller, dynamic, analogue interface
Operating mode	Variable operation
Signal voltage range	0 – 10 V DC
Operating values for factory setting	200 – 900 [m ³ /h]

Order example: TVE/200/D2/XB0/V0/500-1200 [m³/h]

Type	TVE
Acoustic cladding	Without acoustic cladding
Material	Galvanised sheet steel
Duct connection	Push-fit, suitable for ducts according to EN 1506; with groove for optional lip seal
Nominal size [mm]	200
Accessories	Double lip seal both ends
Attachments (control components)	Volume flow controller, dynamic, analogue interface
Operating mode	Variable operation
Signal voltage range	0 – 10 V DC
Operating values for factory setting	500 – 1200 [m ³ /h]

Variants

VAV terminal unit, variant TVE

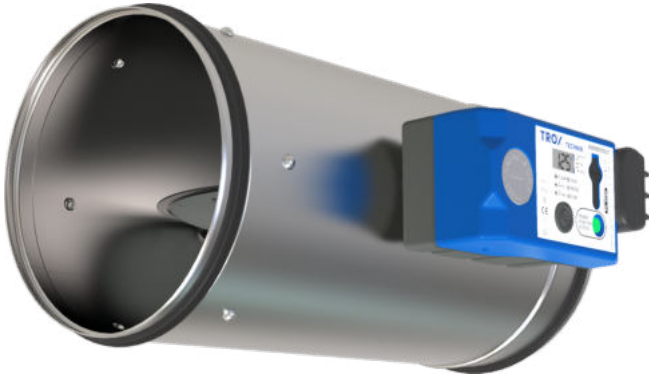

Application

- Spigot
-

VAV terminal unit, variant TVE-D

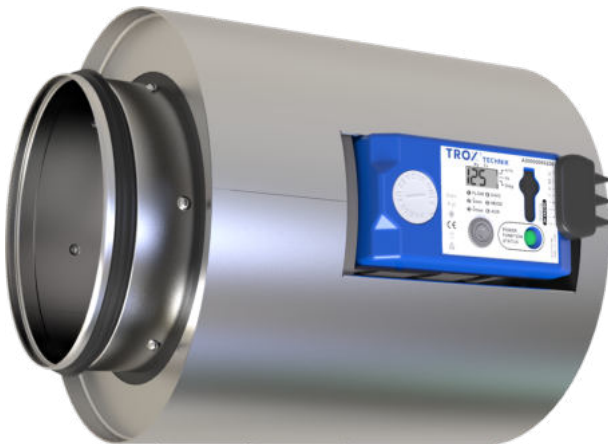

Application

- With acoustic cladding
 - For rooms where the case-radiated noise of the unit is not sufficiently reduced by a false ceiling
 - The circular ducts for the room under consideration must have adequate acoustic insulation (provided by others) on the fan and room ends
 - Acoustic cladding cannot be retrofitted
-

VAV terminal unit, variant TVE-FL



Application

- With flanges on both ends to make detachable connections to the ducting
- Optional available with matching flanges

VAV terminal unit, variant TVE-D-FL

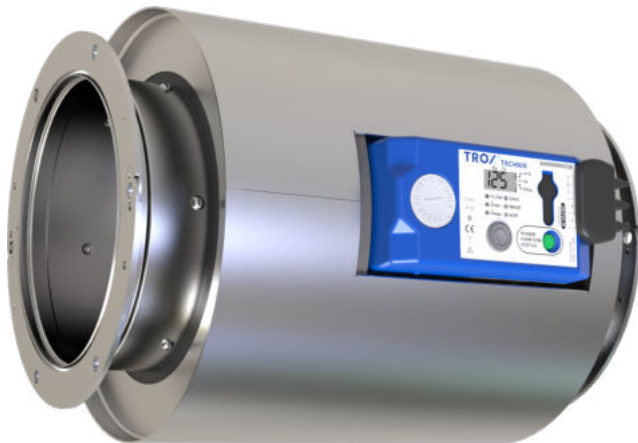

Application

- With flanges on both ends to make detachable connections to the ducting
- With acoustic cladding
- Optional available with matching flanges
- For rooms where the case-radiated noise of the unit is not sufficiently reduced by a false ceiling
- The circular ducts for the room under consideration must have adequate acoustic insulation (provided by others) on the fan and room ends
- Acoustic cladding cannot be retrofitted

Material

Standard construction

Order code detail	Part	Material
-	Casing	Galvanised steel
	Damper blade	Plastic, PA6, UL 94, flame retardant
	Damper blade seal	Plastic, TPU, micro bacterial resistant
	Effective pressure sensor	Plastic, PA6, UL 94, flame retardant
	Plain bearings	Plastic
	Shaft	Plastic, PA6, UL 94, flame retardant

Powder-coated construction

Order code detail	Part	Material
P1	Casing	Galvanised sheet steel - powder coated, RAL 7001, silver grey
	Damper blade	Plastic, PA6, UL 94, flame retardant
	Damper blade seal	Plastic, TPU, micro bacterial resistant
	Effective pressure sensor	Plastic, PA6, UL 94, flame retardant
	Plain bearings	Plastic
	Shaft	Plastic, PA6, UL 94, flame retardant

Stainless steel construction

Order code detail	Part	Material
A2	Casing	Stainless steel, material no. 1.4301
	Damper blade	Plastic, PA6, UL 94, flame retardant
	Damper blade seal	Plastic, TPU, micro bacterial resistant
	Effective pressure sensor	Plastic, PA6, UL 94, flame retardant
	Plain bearings	Plastic
	Shaft	Plastic, PA6, UL 94, flame retardant

Option acoustic cladding

Order code detail	Part	Material
D	Acoustic cladding	Galvanised sheet steel
	Insulation of structure-borne noise	Polyethylene, PE
	Lining	Mineral wool to EN 13501, fire rating class A1, non-combustible

Dimensions and weight

VAV terminal unit without acoustic cladding (TVE)

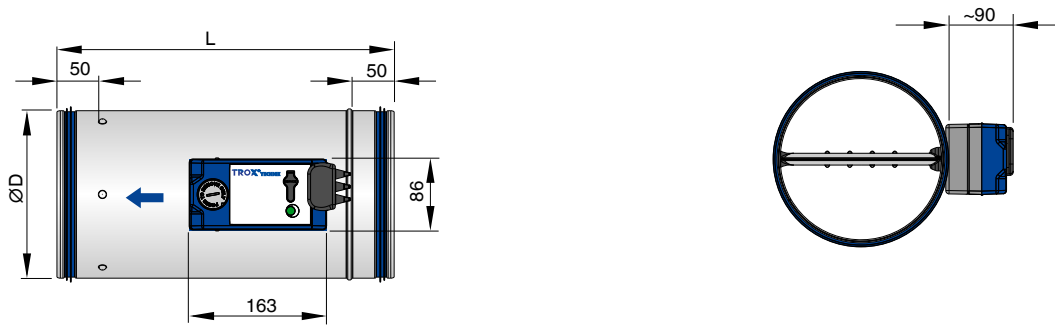

Note:
 Length L depends on the nominal size.
 Lip seals can be selected as an option; note that the illustration does not show the actual product.

Note:
 The illustration shows control component type Easy, Compact.
 For individual dimensions, see section on space requirements for commissioning and maintenance.

Connection type

- Spigot with groove for lip seal, suitable for connecting ducts according to EN 1506 or EN 13180

Dimensions/weight for TVE

NS	L	ØD	kg
100	310	99	1,3
125	310	124	1,5
160	310	159	1,8
200	400	199	2,5
250	400	249	3
315	400	314	3,8
400	485	399	4,9

VAV terminal unit with acoustic cladding (TVE-D)

TVE-D

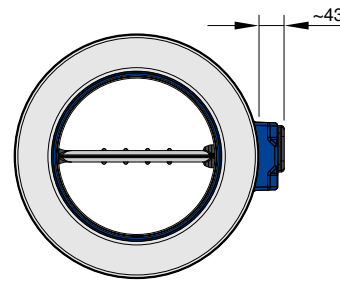
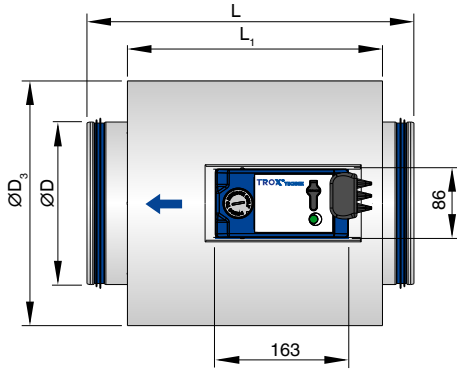

Note:
Length L, L₁ depends on the nominal size.
Lip seals can be selected as an option; note that the illustration does not show the actual product.

Note:
The illustration shows control component type Easy, Compact.
For individual dimensions, see section on space requirements for commissioning and maintenance.

Dimensions/weight TVE-D

NS	L	L ₁	ØD	ØD ₃	kg
100	310	233	99	199	2,6
125	310	233	124	219	3
160	310	233	159	261	3,6
200	400	312	199	299	5
250	400	312	249	354	6,1
315	400	312	314	416	7,5
400	485	417	399	498	10,6

Connection type

- Spigot with groove for lip seal, suitable for connecting ducts according to EN 1506 or EN 13180

Terminal unit with flange (TVE-FL)

TVE-FL

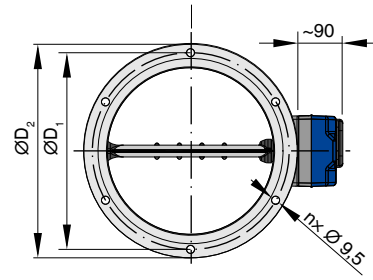
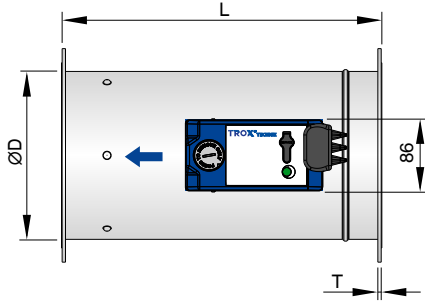

Note:
Length L depending on nominal size.

Note:
The illustration shows control component type Easy, Compact.
For individual dimensions, see section on space requirements for commissioning and maintenance.

Dimensions/weight TVE-FL

NS	L	ØD	ØD ₁	ØD ₂	n	D	kg
100	298	99	132	152	4	5	1,9
125	298	124	157	177	4	5	2,2
160	298	159	192	212	6	5	2,7
200	388	199	233	253	6	5	3,6
250	388	249	283	303	6	5	4,4
315	388	314	352	378	8	5	5,8
400	474	399	438	464	8	5	7,5

Note: Tolerances for dimensions L: ± 5 mm

Terminal unit with acoustic cladding and flange (TVE-D-FL) TVE-D-FL

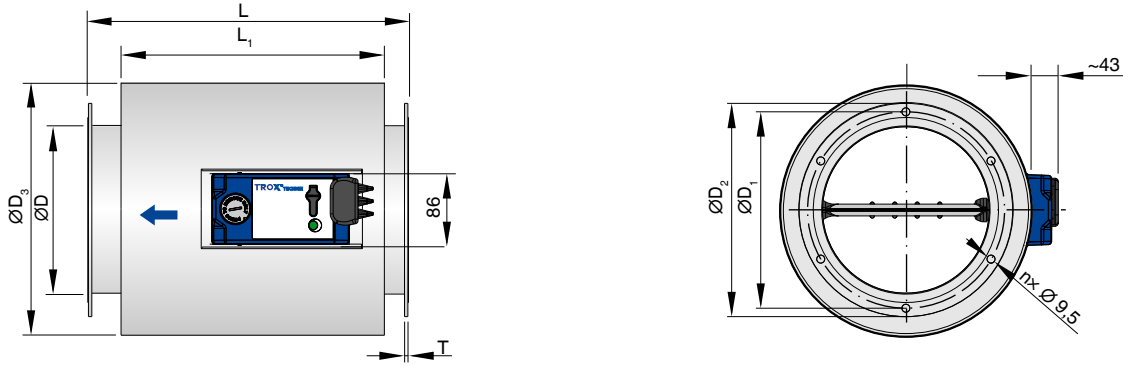

Note:
Length L, L1 depending on nominal size.

Note:
The illustration shows control component type Easy, Compact.
For individual dimensions, see section on space requirements
for commissioning and maintenance.

Dimensions/weight for TVE-D-FL

NS	L	L ₁	ØD	ØD ₁	ØD ₂	ØD ₃	n	D	kg
100	298	233	99	132	152	199	4	5	3,2
125	298	233	124	157	177	219	4	5	3,7
160	298	233	159	192	212	261	6	5	4,5
200	388	312	199	233	253	299	6	5	6,1
250	388	312	249	283	303	354	6	5	7,5
315	388	312	314	352	378	416	8	5	9,5
400	474	417	399	438	464	498	8	5	13,2

Note: Tolerance for dimension L: ± 5 mm

Access to attachments, mounted on one side

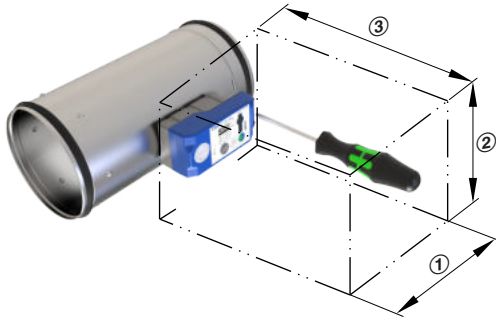

Space requirement, control component on one side

Attachment	①	②	③
Easy controller: Easy	250	200	300
Compact controller: XB0, XM0, XM0-J6, XS0, XS0-J6	250	200	300

Space required for commissioning and maintenance

Keep sufficient space free in the area of the attachments for commissioning and maintenance. It may be necessary to provide sufficiently sized inspection access openings.

Product details

Installation and commissioning

- Any installation orientation
- TVE-D: For constructions with acoustic cladding, ducts on the room side should have cladding up to the acoustic cladding of the controller

Upstream conditions

The effective pressure, which is decisive for the volume flow rate, is recorded and averaged on the control damper blade.

Therefore, the volume flow rate accuracy Δ_{qv} is independent of the upstream section.

Duct connections, e.g. branches off the main duct, must comply with EN 1506 and EN 13180.

Bend

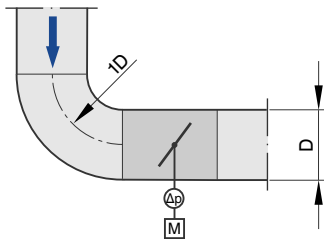

Junction

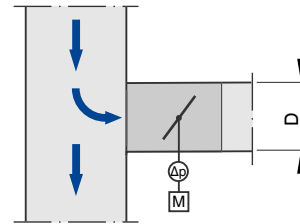

A bend without a straight duct section upstream of the VAV terminal unit has only a negligible effect on the volume flow rate accuracy Δ_{qv} .

A junction causes strong turbulence. The stated volume flow rate accuracy Δ_{qv} can be achieved without upstream section.

TVE control components VARYCONTROL

Attachment	Controlled variable	Interface	Effective pressure transducer	Actuator	Manufacturer
Easy controller, dynamic					
Easy	qv	0 – 10 V	integral	Slow running integral	①
Compact controller, dynamic					
XB0	qv	0 – 10 V or 2 – 10 V	integral	Slow running integral	①
XM0	qv	Modbus RTU interface	integral	Slow running integral	①
XM0–J6	qv	Modbus RTU interface with RJ12 socket (for X-AIRCONTROL)	integral	Slow running integral	①
Compact controller, static					
XS0	qv	Modbus RTU interface	integral	Slow running integral	①
XS0–J6	qv	Modbus RTU interface with RJ12 socket (for X-AIRCONTROL)	integral	Slow running integral	①

 q_v Volume flow rate

① TROX

Nomenclature

Dimensions of rectangular units

B [mm]

Duct width

B₁ [mm]

Screw hole pitch of flange (horizontal)

B₂ [mm]

Overall dimension of flange (width)

H [mm]

Duct height

H₁ [mm]

Screw hole pitch of flange (vertical)

H₂ [mm]

Overall dimension of flange (height)

Dimensions of circular units

ØD [mm]

Basic units made of sheet steel: Outer diameter of the spigot;
basic units made of plastic: Inside diameter of the spigot

ØD₁ [mm]

Pitch circle diameter of flanges

ØD₂ [mm]

Outer diameter of flanges

L [mm]

Length of unit including connecting spigot

L₁ [mm]

Length of casing or acoustic cladding

n []

Number of flange screw holes

T [mm]

Flange thickness

General information

m [kg]

Unit weight including the minimum required attachments (control component)

NS [mm]

Nominal size

f_m [Hz]

Octave band centre frequency

L_{PA} [dB(A)]

A-weighted sound pressure level of air-regenerated noise of the CAV controller, system attenuation taken into account

L_{PA1} [dB(A)]

A-weighted sound pressure level of air-regenerated noise of the CAV controller with secondary silencer, system attenuation taken into account

L_{PA2} [dB(A)]

A-weighted sound pressure level of case-regenerated noise of the CAV controller, system attenuation taken into account

L_{PA3} [dB(A)]

A-weighted sound pressure level of case-regenerated noise of the CAV controller with acoustic cladding, system attenuation taken into account

Note on acoustic data: All sound pressure levels are based on a reference value of 20 µPa.

q_{vNom} [m³/h]; [l/s]

Nominal flow rate (100 %): The value depends on product type, nominal size and control component (attachment). Values are published on the internet and in technical leaflets and stored in the Easy Product Finder design program. Reference value for calculating percentages (e.g. q_{vmax}). Upper limit of the setting range and maximum volume flow rate setpoint value for the VAV terminal unit.

q_{vmin Unit} [m³/h]; [l/s]

Technically possible minimum volume flow rate: The value depends on product type, nominal size and control component (attachment). Values are stored in the Easy Product Finder design program. Lower limit of the setting range and minimum volume flow rate setpoint value for the VAV terminal unit.

Setpoint values below q_{vmin unit} (if q_{vmin} equals zero) may result in unstable control or shut-off.

q_{vmax} [m³/h]; [l/s]

Upper limit of the operating range for the VAV terminal unit that can be set by customers: q_{vmax} can be set to less than or equal to q_{vnom}. For analogue signalling to volume flow controllers (typically used), the maximum value of the setpoint signal (10 V) is assigned the set maximum value (q_{vmax}) (see characteristic).

q_{vmin} [m³/h]; [l/s]

Lower limit of the operating range for the VAV terminal unit that can be set by customers: q_{vmin} should be set to less than or equal to q_{vmax}. Do not set q_{vmin} to less than q_{vmin unit} as the control may become unstable or the damper blade may close. q_{vmin} may equal zero. In case of analogue signalling to volume flow controllers (which are typically used), the set minimum value (q_{vmin}) is allocated to the minimum setpoint signal (0 or 2 V) (see characteristic).

q_v [m³/h]; [l/s]

Volume flow rate

Δ_{qv} [%]

Volume flow rate accuracy in relation to the setpoint (tolerance)

Δp_{st} [Pa]

Static differential pressure

$\Delta_{pst\ min}$ [Pa]

Static minimum differential pressure: The static minimum differential pressure is equal to the pressure loss of the VAV terminal unit when the damper blade is open, caused by flow resistance (damper blade). If the differential pressure on the VAV terminal unit is too low, the setpoint volume flow rate may not be achieved, not even when the damper blade is open. Important factor in designing the ductwork and in rating the fan including speed control. Sufficient static differential pressure must be ensured for all operating conditions and for all controllers, and the measurement point or points for speed control must have been selected accordingly to achieve this.

Lengths

All lengths are given in millimetres [mm] unless stated otherwise.

Basic unit

Unit for controlling a volume flow without an attached control component. The main components include the casing with sensor(s) to measure the effective pressure and the damper blade to restrict the volume flow. The basic unit is also referred

to as a VAV terminal unit. Important distinguishing features: Geometry or unit shape, material and types of connection, acoustic characteristics (e.g. acoustic cladding or integral sound attenuator), volume flow rate range.

Control component

Electronic unit(s) mounted on the basic unit to control the volume flow rate or the duct pressure or the room pressure by adjusting the damper blade position. The electronic unit consists basically of a controller with effective pressure transducer (integral or external) and an integral actuator (Easy and Compact controllers) or external actuator (Universal or LABCONTROL controllers). Important distinguishing features: Transducer: dynamic transducer for clean air or static transducer for contaminated air. Actuator: slow-running actuator as standard, spring return actuator for safe position, or fast-running actuator. Interface: analogue interface or digital bus interface for the capturing of signals and data.

VAV terminal unit

Consists of a basic unit with an attached control component.