



# VAV terminal units

## VARYCONTROL

LVC • TVE • TVR • TVJ • TVT • TZ-/TA-Silenzio  
TVZ • TVA • TVM • TVRK • TVLK



Read the instructions prior to performing any task!

**TROX<sup>®</sup> TECHNIK**  
The art of handling air

**TROX GmbH**

Heinrich-Trox-Platz

47504 Neukirchen-Vluyn

Germany

Telephone: +49 (0) 2845 202-0

Fax: +49 (0) 2845 202-265

E-mail: [trox@trox.de](mailto:trox@trox.de)

Internet: [www.trox.de](http://www.trox.de)

A00000071368, 2, GB/en

03/2020

© TROX GmbH 2018

## General information

### Information about the installation and commissioning manual

This installation and commissioning manual enables operating or service personnel to use the variable air terminal unit (VAV terminal unit) safely and efficiently.

The manual must be kept near the unit to be available for use at all times.

Personnel who intend to work on the VAV terminal unit must read and fully understand this manual before starting any work. The basic prerequisite for safe working is to comply with the safety notes and all instructions in this manual.

The local regulations for health and safety at work and the general safety regulations for the area of application of VAV terminal unit also apply.

Illustrations in this manual are mainly for information and may differ from the actual design.

### Other applicable documentation

In addition to this manual, the following documents apply:

- Product data sheets
- Instructions for the electrical control components (assemblies)
- Project-specific wiring documents, if any

### TROX Technical Service

To ensure that your request is processed as quickly as possible, please keep the following information ready:

- Product name
- TROX order number
- Delivery date
- Brief description of the fault

Online	<a href="http://www.troxtechnik.com">www.troxtechnik.com</a>
Phone	+49 2845 202-400

### Safety notes

Symbols are used in this manual to alert readers to areas of potential hazard. Signal words express the degree of the hazard.

Comply with all safety instructions and proceed carefully to avoid accidents, injuries and damage to property.

#### **DANGER!**

Imminently hazardous situation which, if not avoided, will result in death or serious injury.

#### **WARNING!**

Potentially hazardous situation which, if not avoided, may result in death or serious injury.

#### **CAUTION!**

Potentially hazardous situation which, if not avoided, may result in minor or moderate injury.

#### **NOTICE!**

Potentially hazardous situation which, if not avoided, may result in property damage.

#### **ENVIRONMENT!**

Environmental pollution hazard.

### Tips and recommendations



*Useful tips and recommendations as well as information for efficient and fault-free operation.*

## Safety notes as part of instructions

Safety notes may refer to individual instructions. In this case, safety notes will be included in the instructions and hence facilitate following the instructions. The above listed signal words will be used.

Example:

1. ▶ Loosen the screw.

2. ▶



**CAUTION!**

**Danger of finger entrapment when closing the lid.**

Be careful when closing the lid.

3. ▶ Tighten the screw.

## Specific safety notes

The following symbols are used in safety notes to alert you to specific hazards:

Warning signs	Type of danger
	Warning – high-voltage.
	Warning – danger zone.

<b>1</b>	<b>Security</b> .....	<b>6</b>	<b>8</b>	<b>Troubleshooting</b> .....	<b>28</b>
	1.1 Correct use.....	6	<b>9</b>	<b>K values</b> .....	<b>29</b>
	1.2 Safety signs.....	6	<b>10</b>	<b>Control component/attachments</b> .....	<b>31</b>
	1.3 Residual risks.....	6	<b>11</b>	<b>Declaration of conformity</b> .....	<b>32</b>
	1.3.1 Electric shock hazards.....	6			
	1.4 System owner's responsibility.....	7			
	1.5 Staff.....	7			
	1.6 Personal protective equipment.....	7			
	1.7 General safety measures.....	8			
	1.8 Repair and replacement parts.....	8			
<b>2</b>	<b>Transport, storage and packaging</b> .....	<b>9</b>			
	2.1 Delivery check.....	9			
	2.2 Transport on site.....	9			
	2.3 Storage.....	9			
	2.4 Packaging.....	9			
<b>3</b>	<b>Product description</b> .....	<b>10</b>			
	3.1 VAV terminal unit types.....	10			
	3.1.1 Round VAV terminal units, steel.....	10			
	3.1.2 Rounded VAV terminal units, plastic.....	11			
	3.1.3 Rectangular VAV terminal units, steel ...	12			
	3.2 Detection of the control components.....	14			
	3.3 Position of the damper blade.....	14			
<b>4</b>	<b>Installation</b> .....	<b>15</b>			
	4.1 Security.....	15			
	4.2 Installation information.....	15			
	4.3 Installation orientation.....	15			
	4.4 Direction of airflow.....	15			
	4.5 Upstream conditions.....	16			
	4.5.1 Circular ducting.....	16			
	4.5.2 Rectangular ducting.....	17			
	4.6 Affixing/suspension.....	19			
	4.6.1 General information.....	19			
	4.6.2 Rounded units.....	19			
	4.6.3 Rectangular units.....	20			
	4.6.4 Installation of secondary silencer.....	20			
	4.7 Connecting the duct.....	22			
<b>5</b>	<b>Wiring</b> .....	<b>24</b>			
	5.1 Installation notes.....	24			
<b>6</b>	<b>Commissioning and operation</b> .....	<b>25</b>			
	6.1 Commissioning.....	25			
	6.2 Operation.....	25			
	6.3 Volume flow rate measurement.....	26			
	6.3.1 Volume flow rate calculation.....	26			
<b>7</b>	<b>Maintenance</b> .....	<b>27</b>			
	7.1 System owner's responsibility.....	27			
	7.2 Maintenance.....	27			
	7.3 Inspection measures.....	27			
	7.4 Repair.....	27			
	7.5 Maintenance service.....	27			

## 1 Security

### 1.1 Correct use

#### VAV terminal units

VAV terminal units are designed for variable volume flow control, restriction or shut-off in room air distribution and ventilation systems within closed rooms.

Do not use VAV terminal units in extract air systems in commercial kitchens unless the extract air has been cleaned as much as possible with high-efficiency aerosol separators; see VDI 2052.

Only VAV terminal units with static pressure transmitters are allowed to be used in ventilation systems with dust-laden air.

Only VAV terminal units of the TVLK and TVRK types are allowed to be used in ventilation systems with chemical contamination (e.g. extract air from fume cupboards).

#### Incorrect use

#### WARNING!

##### **Danger of injury or risk of damage to property due to incorrect use!**

Incorrect use of the VAV terminal unit can lead to dangerous situations.

Do not use the VAV terminal unit:

- in areas with potentially explosive atmospheres
- in aircraft
- outdoors without sufficient protection against the effects of weather
- in wet areas
- for areas of application that are not described in this manual

Modifying the unit or using replacement parts that have not been approved by TROX is not permitted.

### 1.2 Safety signs

The following symbols and signs are usually found in the work area. They apply to the very location where they are found.

#### WARNING!

##### **Danger due to illegible signage!**

Over time, stickers and signs may fade or become otherwise illegible, meaning that hazards cannot be identified and necessary operating instructions cannot be followed. There is then a risk of injury.

- Ensure that all of the safety, warning and operating information is clearly legible.
- Replace illegible signs or stickers immediately.

### Electrical voltage



Only skilled qualified electricians are allowed to work in areas marked as having electrical voltage.

Unauthorised persons must not enter areas, open cabinets or work on components where an electrical voltage is present and which are hence marked with this symbol.

### 1.3 Residual risks

The VAV terminal unit is a state-of-the-art product and meets current safety requirements. Residual risks cannot be excluded, however, and you should proceed with caution. This section describes the residual risks that have been identified in a risk assessment.

Always observe the safety notes in this manual to reduce health hazards and prevent any hazardous situations.

#### 1.3.1 Electric shock hazards

##### Electric current

#### DANGER!

##### **Danger of death due to electric current!**

Danger of electric shock! Do not touch any live components! Damaged insulation or damaged parts are a life threatening hazard.

- Have work on the electrical system carried out only by skilled qualified electricians.
- If the insulation is damaged, disconnect the power supply immediately and have the insulation repaired.
- Before you start working on electric systems and equipment, switch off the supply voltage and secure it against being switched on accidentally. Comply with the following safety rules:
  - Switch off the power supply.
  - Secure it against being switched on accidentally.
  - Ensure that no voltage is present.
  - Connect to the earth; short circuit connection.
- Do not bypass or disable any circuit breakers. Be sure to maintain the correct current rating when you replace a circuit breaker.
- Ensure that live parts do not come into contact with moisture. Moisture can cause a short circuit.

## 1.4 System owner's responsibility

### System owner

The system owner is a natural or legal person who for commercial or business purposes owns or manages the ventilation system or component or allows third parties to use or operate it, but continues to bear legal responsibility for the safety of users, staff or third parties while the product is in use.

### System owner's obligations

The unit is intended for commercial use. The system owner is therefore subject to the legal obligations of occupational health and safety regulations.

In addition to the safety notes in this manual, the applicable regulations for safety, accident prevention and environmental protection must also be complied with.

In particular:

- The system owner must be aware of the applicable occupational health and safety regulations and carry out a risk assessment to determine any additional hazards that may exist or result from the specific working conditions at the installation location. The system owner has to create operating instructions for the unit that reflect the results of this risk assessment.
- The system owner has to ensure, throughout the entire operating period of the unit, that these operating instructions conform to applicable standards and guidelines; in case of any deviation, the system owner has to adapt the instructions.
- The system owner must secure the unit to prevent access by unauthorised individuals.
- The system owner must clearly define the responsibilities for operation, maintenance, cleaning, troubleshooting and removal.
- The system owner has to ensure that all individuals who handle or use the unit have read and understood this manual.
- The system owner must provide the employees with the required personal protective equipment.
- The system owner must observe the local fire regulations.

### Hygiene requirements

The system owner has to comply with the local regulations and harmonised standards for hygiene requirements. This includes regular maintenance and inspection intervals.

## 1.5 Staff

### Qualification

The work described in this manual has to be carried out by individuals with the qualification, training, knowledge and experience described below:

### HVAC technician

HVAC technicians are individuals who have sufficient professional or technical training in the field they are working in to enable them to carry out their assigned duties at the level of responsibility allocated to them and in compliance with the relevant guidelines, safety regulations and instructions. HVAC technicians are individuals who have in-depth knowledge and skills related to HVAC systems; they are also responsible for the professional completion of the work under consideration.

HVAC technicians are individuals who have sufficient professional or technical training, knowledge and actual experience to enable them to work on HVAC systems, understand any potential hazards related to the work under consideration, and recognise and avoid any risks involved.

### Skilled qualified electrician

Skilled qualified electricians are individuals who have sufficient professional or technical training, knowledge and actual experience to enable them to work on electrical systems, understand any potential hazards related to the work under consideration, and recognise and avoid any risks involved.

## 1.6 Personal protective equipment

Personal protective equipment is equipment that protects the user against health or safety risks at work.

Personal protective equipment must be worn for various types of work; the protective equipment required is listed in this manual together with the description of each type of work.

### Description of personal protective equipment

#### Industrial safety helmet



Industrial safety helmets protect the head from falling objects, suspended loads, and the effects of striking the head against stationary objects.

#### Protective gloves



Protective gloves protect hands from friction, abrasions, punctures, deep cuts, and direct contact with hot surfaces.

## Safety shoes



Safety shoes protect the feet from crushing, falling parts and prevent slipping on a slippery floor.

## 1.7 General safety measures

### Large temperature differences

Be careful when there is a large temperature difference. Do not put the VAV terminal unit into operation immediately if it has been transported from an unheated area to a warm one. Condensation may damage the electronic components beyond repair. Only after about 2 hours will the system have reached room temperature.

### Foreign matter and liquids

Be careful when objects or liquids have got into the casing, or if the unit emits a smell or smoke. Decommission the VAV terminal unit and have it checked by the manufacturer.

## 1.8 Repair and replacement parts

Only qualified personnel are allowed to repair the devices and only genuine replacement parts are allowed to be used. This applies in particular to work on the electrical equipment. For safety reasons, therefore, have defective devices repaired by TROX Technical Service, ↪ *'TROX Technical Service'* on page 3.



## 2 Transport, storage and packaging

### Sharp edges and sheet metal parts



#### CAUTION!

**Danger of injury from sharp edges and sheet metal parts.**

- Always wear protective gloves when handling the unit.

### Damage to the VAV terminal unit



#### NOTICE!

**Risk of damage to the VAV terminal unit!**

- Handle the unit with care.
- Do not lift the VAV terminal unit by its control components, the damper blade or differential pressure sensor.
- Lift the unit only by lifting the entire casing.

### 2.1 Delivery check

Check delivered items immediately after arrival for transport damage and completeness. In case of any damage or an incomplete shipment, contact the shipping company and your supplier immediately.

### 2.2 Transport on site

- If possible, take the VAV terminal unit in its transport packaging up to the installation location.
- Do not remove the protective wrapping until just before installation.

### 2.3 Storage

If the product has to be stored temporarily:

- Moisture and lack of ventilation can lead to oxidation, even on galvanised components. Remove any plastic wrapping in order to avoid oxidation.
- Protect the product from dust and contamination.
- Store the product in a dry place and away from direct sunlight.
- Do not store the product below -10 °C or above +50 °C.

### 2.4 Packaging

Properly dispose of packaging material.

## 3 Product description

### 3.1 VAV terminal unit types

#### 3.1.1 Round VAV terminal units, steel

Type	Illustration	Description
LVC		<ul style="list-style-type: none"> <li>① Differential pressure sensor (plastic nozzle)</li> <li>② Damper blade</li> <li>③ Lip seal</li> <li>④ Easy controller</li> <li>⑤ Volume flow rate scale</li> <li>⑥ Wire clamping bracket</li> </ul>
TVE		<ul style="list-style-type: none"> <li>① Lip seal</li> <li>② Casing</li> <li>③ Damper blade with integrated differential pressure sensor</li> <li>④ Shaft</li> <li>⑤ Control components, e.g. a compact controller</li> </ul>
TVR		<ul style="list-style-type: none"> <li>① Differential pressure sensor</li> <li>② Damper blade</li> <li>③ Lip seal</li> <li>④ Control components, e.g. Easy controllers</li> </ul>

3.1.2 Rounded VAV terminal units, plastic

Type	Illustration	Description
TVRK		<ul style="list-style-type: none"> <li>① Differential pressure sensor</li> <li>② Damper blade</li> <li>③ Casing</li> <li>④ Actuator</li> <li>⑤ Control components, e.g. a Universal controller</li> </ul>
TVLK		<ul style="list-style-type: none"> <li>① Differential pressure sensor (nozzle, optional)</li> <li>② Control component, e.g. LABCONTROL controller EASYLAB</li> <li>③ Casing</li> <li>④ Actuator</li> <li>⑤ Differential pressure sensor (bluff body and sensor tubes)</li> </ul>

## 3.1.3 Rectangular VAV terminal units, steel

Type	Illustration	Description
TVJ		<ul style="list-style-type: none"> <li>① Differential pressure sensor</li> <li>② Damper blade</li> <li>③ Gear</li> <li>④ Control components, e.g. Easy controllers</li> </ul>
TVT		<ul style="list-style-type: none"> <li>① Differential pressure sensor</li> <li>② Damper blade with seal</li> <li>③ Gear</li> <li>④ Control components, e.g. Easy controllers</li> </ul>
TZ-Silenzio		<ul style="list-style-type: none"> <li>① Integral sound attenuator</li> <li>② Differential pressure sensor</li> <li>③ Control components, e.g. Easy controllers</li> <li>④ Damper blade with seal</li> </ul>
TA-Silenzio		<ul style="list-style-type: none"> <li>① Integral sound attenuator</li> <li>② Differential pressure sensor</li> <li>③ Control components, e.g. Easy controllers</li> <li>④ Damper blade with seal</li> </ul>

Type	Illustration	Description
TVZ		<ul style="list-style-type: none"> <li>① Differential pressure sensor</li> <li>② Lip seal</li> <li>③ Inspection access</li> <li>④ Damper blade</li> <li>⑤ Integral sound attenuator</li> <li>⑥ Control components, e.g. Easy controllers</li> </ul>
TVA		<ul style="list-style-type: none"> <li>① Integral sound attenuator</li> <li>② Lip seal</li> <li>③ Damper blade</li> <li>④ Differential pressure sensor</li> <li>⑤ Control components, e.g. Easy controllers</li> </ul>
TVM		<ul style="list-style-type: none"> <li>① Damper blade – cold air</li> <li>② Lip seal</li> <li>③ Differential pressure sensor – cold air</li> <li>④ Control components, e.g. compact controllers</li> <li>⑤ Inspection access</li> <li>⑥ Differential pressure sensor – total air</li> <li>⑦ Noise insulation</li> <li>⑧ Damper blade – warm air</li> </ul>

**Notes for terminal units for duct pressure control**

The accessibility of the connections for the differential pressure sensors varies depending on the version of the VAV terminal unit, and the control components installed.

VAV terminal units intended for duct pressure control require a suitable pressure tapping point in the duct system to be controlled. In VAV terminal units with control components for duct pressure control, the differential pressure sensor installed in the VAV terminal unit has no function and is therefore either not accessible or designed without tubing to the control component.

## 3.2 Detection of the control components

The attached control component can be identified on the adjustment label of the VAV terminal unit, see marking Fig. 1 and Fig. 2.

Possible combinations of VAV controller and control component ↪ Chapter 10 'Control component/attachments' on page 31

		TROX GmbH Heinrich-Trox-Platz D-47504 Neukirchen-Vluyn
COM: 000000000.0001.234		
TYP: TA-Silenzio / 315 / <b>XB0</b> / V0		
OP : 0-10V/150-300m³/h /CCW(i)		
LIM: V: 3024 m³/h		C: 223
HW : 227V-024-10-DD3 /SP		
SW : V253 #160831110144-2		
ID : DE.2.01.2017234.0013		

Fig. 1: Calibration sticker variant 1

Com. 111111-222-333	
Unit type: TVR	
Size: 160	
Operation mode: E0	
V Nom: 900 m³/h	Operator
Pw: 224 Pa/Vnom	26.02.2015
	SCHLATH
min: 200 m³/h	
max: 700 m³/h	
U5min: 2,2 VDC U5max: 7,8 VDC	
U5zu: 0,0 VDC U5nom: 10,0 VDC	
Controller: <b>BC0</b> [CCW]	
[No. 01437-30017-158-139]	
LMV-D3-MP	

Fig. 2: Calibration sticker variant 2

## 3.3 Position of the damper blade

The position of the damper blade corresponds to the mark on the axis and is thus recognisable from the outside.

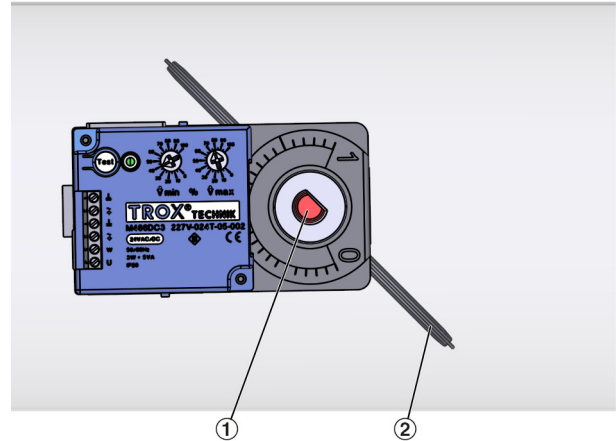

Fig. 3: Actuators with positive locking

- 1 Shaft with marking for position indication
- 2 Damper blade

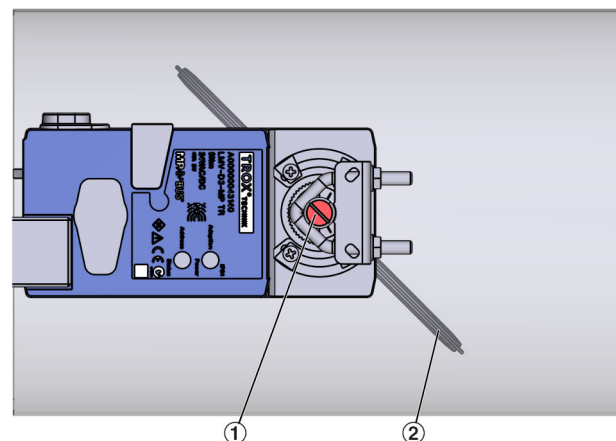

Fig. 4: Actuator with traction

- 1 Shaft with marking for position indication
- 2 Damper blade

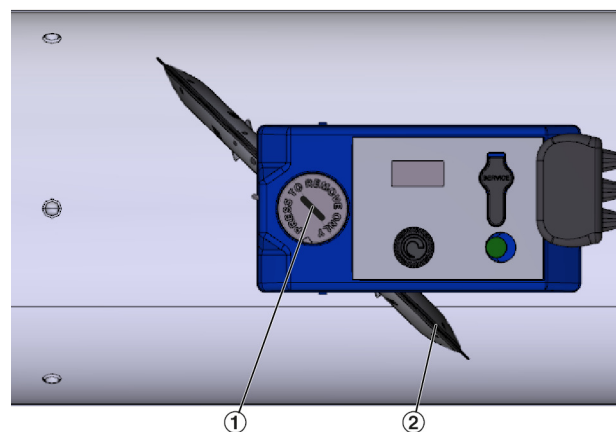

Fig. 5: Actuator on TVE

- 1 Shaft with marking for position indication
- 2 Damper blade



## 4 Installation

### 4.1 Security

**Personnel:**

- HVAC technician

**Protective equipment:**

- Protective gloves
- Safety shoes
- Industrial safety helmet

Only specialist personnel are allowed to perform the described work on the VAV terminal unit.

Only skilled qualified electricians are allowed to work on the electrical system.

**⚠ CAUTION!**  
**Danger of injury from sharp edges and sheet metal parts.**

- Always wear protective gloves when handling the unit.

**! NOTICE!**  
**Risk of damage to the VAV terminal unit!**

- Handle the unit with care.
- Lift the unit only by lifting the entire casing.
- Never lift the unit by its control components, the damper blade or differential pressure sensor.

### 4.2 Installation information

- Select the installation location for the VAV terminal unit such that the VAV terminal unit, inspection accesses and the control components remain accessible for the following work:
  - Wiring
  - Adjustment work (service socket if necessary)
  - Servicing and maintenance, e.g. to replace control components, if necessary in several parts (controllers, transducers, actuators).

For information on space requirements, see product data sheets.

- Observe the air direction arrows on the units.
- Do not swap supply and extract air units.
- Do not swap over devices that belong together in command and tracking controls (e.g. supply air and extract air).
- VAV terminal units are only allowed to be installed in extract air systems in commercial kitchens if the extract air has already been cleaned with aerosol separators, see VDI 2052.

### 4.3 Installation orientation

In the case of terminal units with diaphragm pressure transducers, the installation orientation of the control component must be observed; possible installation orientations are indicated on a sticker (Fig. 6) on the terminal unit.

Other installation orientations or relocation of the pressure transducer only after consultation with TROX.

The mounting position is freely selectable for terminal units without installation orientation stickers.

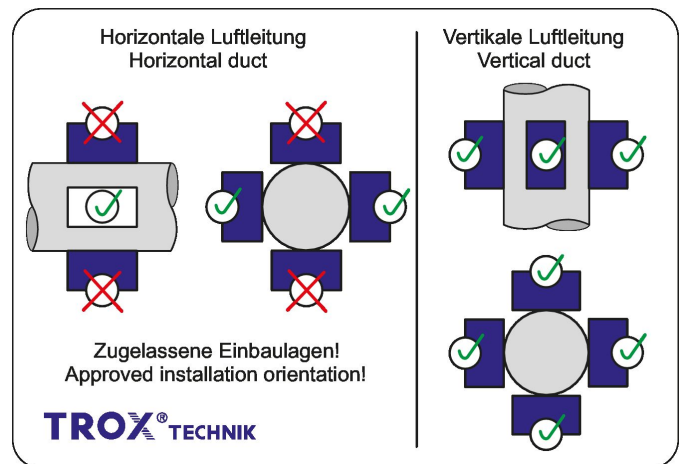

Fig. 6: Sticker showing installation orientations

- ✓ Installation orientation OK
- ✗ Installation orientation not OK

### 4.4 Direction of airflow

It is imperative that air terminal units are installed in their intended airflow direction. For this purpose, an air direction arrow (Fig. 7/1, Fig. 8/1, Fig. 9/1) is attached to the terminal unit. The air direction arrows are designed differently depending on the combination of terminal unit and control component.

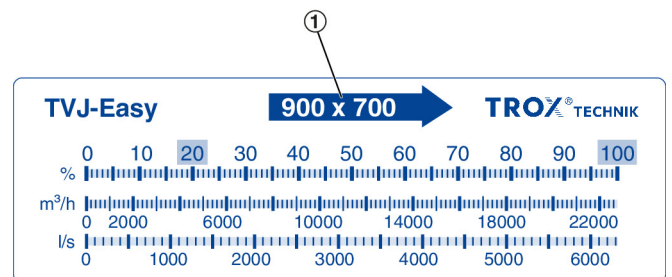

Fig. 7: Air direction arrow on the scale sticker for Easy type control components

Auftrag - Pos		1 / 1
<b>DE1139345-80-4</b>		
<b>GS</b>		
Best.-Nr. : 134126		
Empfänger: Trox Hesco (Schweiz) AG		
Walderstrasse		
CH 8630 Rütli		
<b>CH</b>		
Absender : TROX GmbH		
Gendringer Straße		
DE 46419 Isselburg		
Spediteur : M + R Spedag Group AG, Muttenz		
Sendung :		
TZ-Silenzio-D/125/BC0		
TZ-Silenzio-D/125/BC0/E0/108-648m3/h		
Projekt: 784666		
PA 221212522 ,LOS 100565170		
TERMIN 19.07.2018,PROJ DE1139345		
---> <b>LUFT/AIR</b> --->		

Fig. 8: Air direction arrow on the order sticker



Fig. 9: Air direction arrow on the TVLK

## Airflow direction control unit TVE

In the case of TVE in combination with a control component with a dynamic differential pressure transducer (Easy, XB0, XM0 (-J6)), the airflow direction is arbitrary.

**If Easy, XB0 or XM0(-J6) is listed on the commission sticker, the airflow direction (Fig. 8/1) specified there can be ignored.**

For the TVE with the Easy control component, this is indicated by the double arrow (Fig. 10/1) on the scale label.

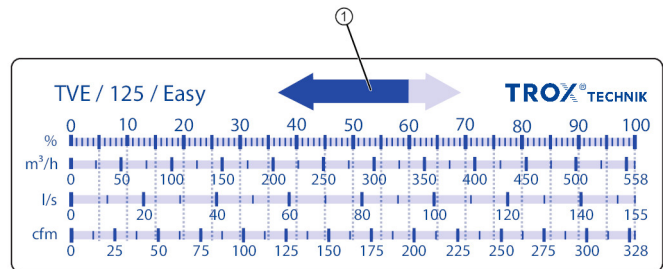

Fig. 10: TVE Easy air direction arrow on the scale sticker

## 4.5 Upstream conditions

The volume flow rate accuracy of VAV terminal units applies to a straight upstream section of the duct. Bends, junctions or a narrowing or widening of the duct cause turbulence that may affect measurement.

Some terminal units require straight upstream duct sections which are explained below.

### 4.5.1 Circular ducting

- **ATTENTION:** Observe air direction arrows on VAV terminal units during installation 15
- Observe EN 1506 for fittings and bridges, in particular:
  - No sharp-edged bridges
  - Slants at reductions and expansions per leg max. 7.5°
- Circular silencers CA/CS/CF (same nominal size) can be installed directly in front of or behind a VAV terminal unit.
- Circular silencer CB (same nominal size)
  - In front of the VAV terminal unit: install at a distance 1D
  - Behind the VAV terminal unit: install at a distance 1D (acoustic decoupling)
- Connection of fire dampers (same nominal size):
  - In front of the VAV terminal unit: at a distance 1D
  - Behind the VAV terminal unit: without distance, observe the movement range of the damper blade.



Upstream conditions with circular ducting

Type	Bend	Junction
LVC	↪ Fig. 11	- 1
TVE		
TVR		
TVZ		↪ Fig. 12
TVM		
TVRK		
TVLK		

1) No straight entry flow required

**Bend: LVC, TVE, TVR, TVZ, TVM, TVRK, TVLK**

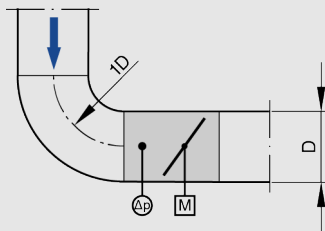

Fig. 11: Bend

A bend with a centre line curvature radius of at least 1D – without an additional straight duct section upstream of the VAV terminal unit – has only a negligible effect on the volume flow rate accuracy.

**Junction: TVR, TVZ, TVM, TVRK**

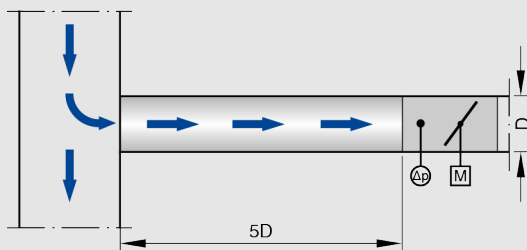

Fig. 12: Rounded junction from a main duct

A junction causes strong turbulence. The stated volume flow rate accuracy can only be achieved with a straight duct section of at least 5D upstream.

4.5.2 Rectangular ducting

- **ATTENTION:** Observe air direction arrows on VAV terminal units during installation ↪ 15
- Observe EN 1505 for fittings and bridges, in particular:
  - No sharp-edged bridges
  - At reductions and expansions: slants max. 7.5° per leg
- Secondary silencer TX can be installed directly upstream/downstream of the volume flow controller, non-active section to the volume flow controller, Fig. 26.
- For splitter sound attenuators MSA, XSA, RSA, keep a distance of 4H in front of the VAV terminal unit.
- Connection of fire dampers (same nominal size):
  - In front of the VAV terminal unit: at a distance 4H
  - Behind the VAV terminal unit: without distance, observe the movement range of the damper blade.

Upstream conditions with rectangular ducting

Type	Bend		Junction	
	horiz.	vertical	horiz.	vertical
TVJ	↪ Fig. 13	↪ Fig. 14	↪ Fig. 16	↪ Fig. 17
TVT				
TZ-Silenzio	↪ Fig. 15		↪ Fig. 18	
TA-Silenzio			↪ Fig. 19	
TVA			↪ Fig. 18 / Fig. 19	

## Bend in horizontal ducting: TVJ, TVT

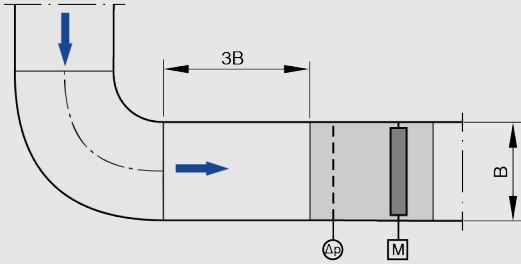

Fig. 13: Horizontal bend connection (view from above)

A bend – with a straight duct section of at least  $3B$  upstream of the VAV terminal unit – has only a negligible effect on the volume flow rate accuracy.

## Bend in vertical ducting: TVJ, TVT

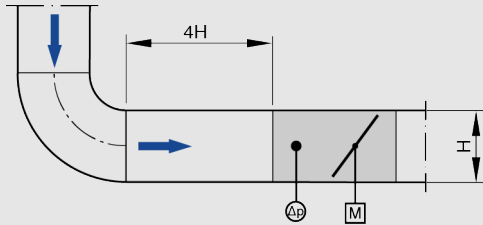

Fig. 14: Vertical bend connection (view from the side)

A bend – with a straight duct section of at least  $4H$  upstream of the VAV terminal unit – has only a negligible effect on the volume flow rate accuracy.

## Bend: TZ-/TA-Silenzio, TVA

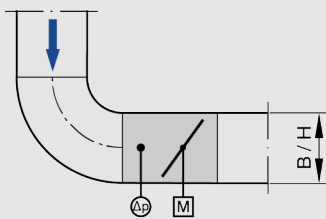

Fig. 15: Bend connection, vertical or horizontal

A bend – without a straight duct section upstream of the VAV terminal unit – has only a negligible effect on the volume flow rate accuracy

## Junction from horizontal main duct: TVJ, TVT

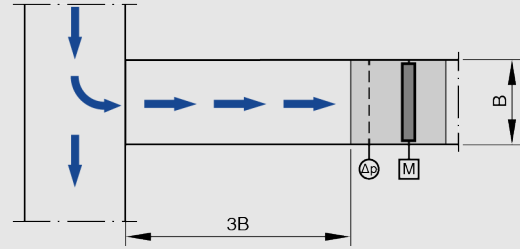

Fig. 16: Junction from a horizontal main duct (view from above)

A junction causes strong turbulence. The stated volume flow rate accuracy can only be achieved with a straight duct section of at least  $3B$  upstream.

## Junction from vertical main duct: TVJ, TVT

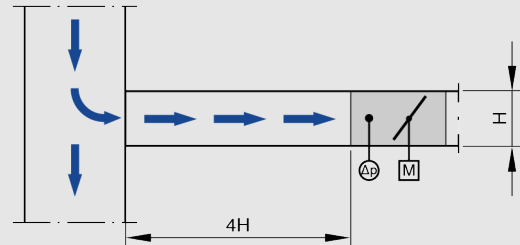

Fig. 17: Junction from a vertical main duct (view from the side)

A junction causes strong turbulence. The stated volume flow rate accuracy can only be achieved with a straight duct section of at least  $4H$  upstream.

## Junction: TZ-Silenzio

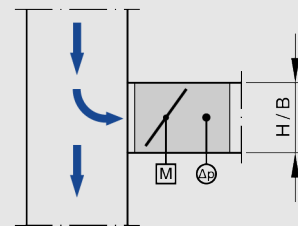

Fig. 18: Junction from a main duct, vertical or horizontal

The stated volume flow rate accuracy is achieved even with a direct connection to the junction of a main duct.

**Junction: TA-Silenzio, TVA**

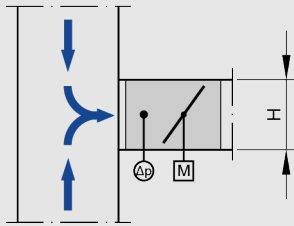

Fig. 19: Convergence of two airflows

The stated volume flow rate accuracy will be achieved even when the VAV terminal unit is connected at a junction and at the point of convergence of two airflows.

**4.6 Affixing/suspension**

**4.6.1 General information**

- When designing and constructing ventilation and air conditioning systems, take into account the requirements of VDI 6022, in particular:
  - Hygienic, clean installation of all components and their air distribution surfaces
  - Inspection and cleaning options for VAV terminal units, e.g. by planning inspection/cleaning openings in the ducting system
  - Avoidance of leaks
- Affix the unit proficiently and only to load-bearing components.
- Load suspension systems only with the weight of the unit. Adjacent components and connecting ducts must be supported separately.
- Only use approved and sufficiently dimensioned suspensions for affixing. Secure screw connections against self-loosening, e. g. by locking them. Affixing material is not included in the supply package.
- Only use the shortest possible drilling screws for affixing; these must not be screwed into the area of the damper blade or differential pressure sensor.

**4.6.2 Rounded units**

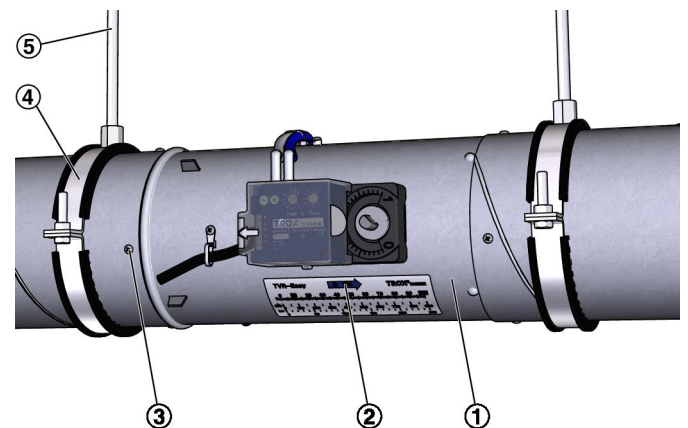

Fig. 20: Installation example TVR-\*

- 1 Terminal unit, rounded, e. g. TVR
- 2 Air direction arrow e. g. on the scale sticker
- 3 Drilling screw for affixing to the ducting
- 4 Clamp
- 5 Suspension, e. g. with threaded rod

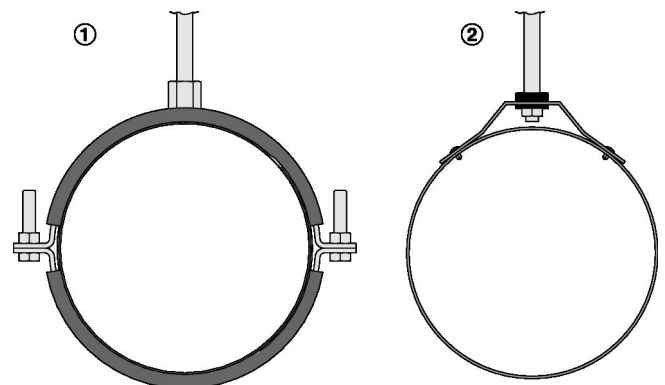

Fig. 21: Examples of fixings for rounded units

- 1 Affixing to pipe clamps
- 2 Affixing to suspension element

## 4.6.3 Rectangular units

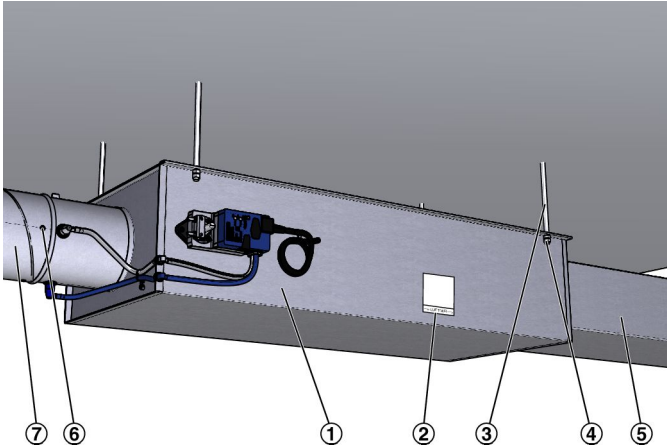

Fig. 22: Installation example directly on the terminal unit

- 1 Terminal unit, rectangular, e. g. TVZ
- 2 Air direction arrow e. g. on the order sticker
- 3 Suspension, e. g. with threaded rod
- 4 Nut, with locknut
- 5 Duct, rectangular
- 6 Drilling screw for affixing to the ducting
- 7 Duct, circular

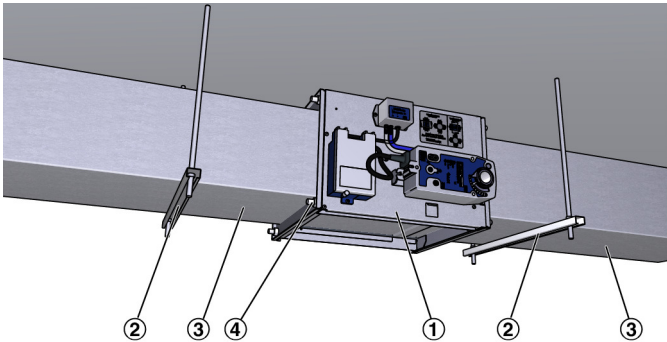

Fig. 23: Installation example suspension on ducting

- 1 Terminal unit, rectangular, e. g. TVJ
- 2 Suspension, e. g. with U-channel, threaded rod nuts with locknuts
- 3 Duct, rectangular
- 4 Affixing the duct to the terminal unit

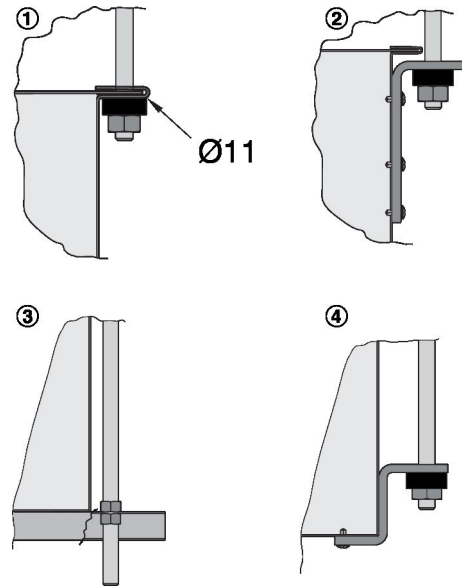

Fig. 24: Examples of fixings for rectangular units

- 1 Affixing to existing drilled holes (only for TVM, TVZ, TVA, TZ-/TA-Silenzio)
- 2 Affixing to duct bracket (L-bracket)
- 3 Affixing with bracket or U-channel
- 4 Affixing to duct bracket (Z-bracket)

## 4.6.4 Installation of secondary silencer

Secondary silencers are supplied separately and must be mounted directly on the VAV terminal unit at the installation location. Suspend sound attenuator separately.

### Secondary silencer TX

To optimise acoustics and flow, the TX sound attenuator has an empty chamber. When mounting, observe the arrangement of the empty chamber depending on the installation location of the sound attenuator (in front of or behind the terminal unit in air direction).

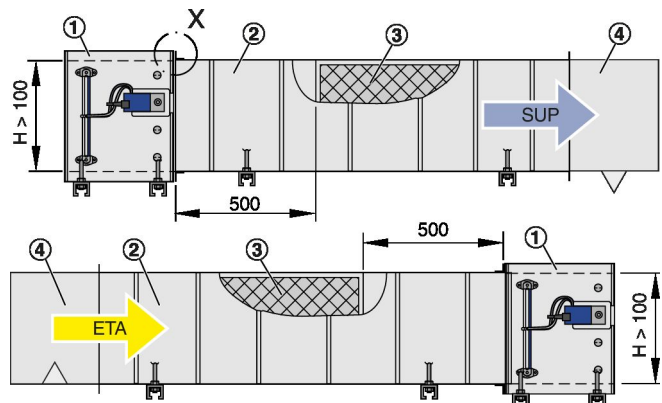

Fig. 25: Installation of sound attenuator TX  $H > 100$  mm

- 1 VAV terminal unit TVJ-\* / TVT-\*
- 2 Sound attenuator TX
- 3 Splitter
- 4 Air terminal device (room end)

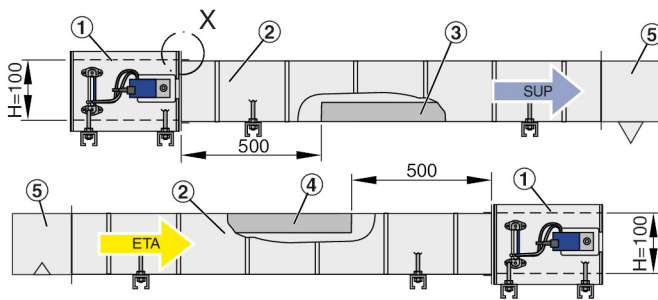

Fig. 26: Installation of sound attenuator TX H = 100 mm

- 1 VAV terminal unit TVJ-\* / TVT-\*
- 2 Sound attenuator TX
- 3 Splitter at bottom (TX behind TVJ / TVT in airflow direction)
- 4 Splitter at top (TX in front of TVJ / TVT in airflow direction)
- 5 Air terminal device (room end)

For sound attenuators with a height of H = 100 mm, observe the position of the splitter (top or bottom).

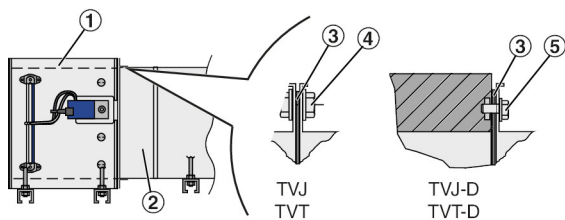

Fig. 27: Detail X

- 1 VAV terminal unit TVJ-\* / TVT-\*
- 2 Sound attenuator TX
- 3 Seal (to be provided by others)
- 4 4 screws / washers / nuts M8 or M10 (to be provided by others)
- 5 4 washers / screws / M8 × 16 (to be provided by others)

### Secondary silencer TS

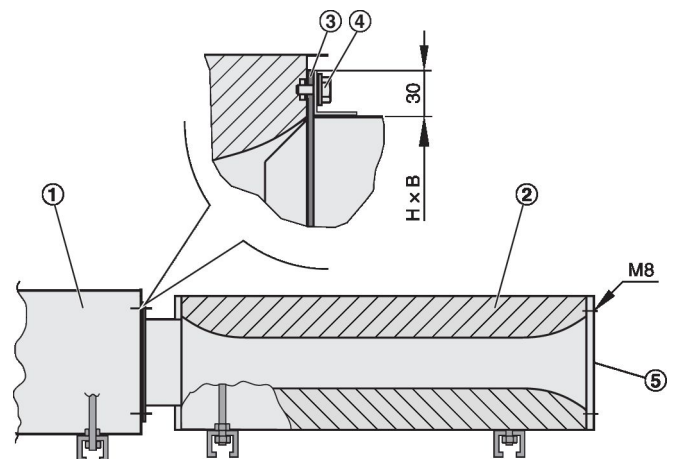

Fig. 28: Installation of sound attenuator TS

- 1 VAV terminal unit TVZ, TVA, TZ-/TA-Silenzio, TVM
- 2 Sound attenuator TS
- 3 Seal (to be provided by others)
- 4 4 screws M8 × 16 (to be provided by others)
- 5 Room end

## 4.7 Connecting the duct

When connecting the ducting, the customer must ensure that the connection points are installed as air-tight as possible in order to avoid negative influences from leakages such as air volume deviations, power consumption, etc. Unless otherwise specified, the connecting material is not included in the supply package. In the case of one-sided connection of the ductwork, intervention in the damper blade is to be prevented by suitable measures (for example grilles).

Before connecting the ducting:

- Check the inside of the unit for damage and loose parts.
- Remove any contamination from the ducting.

### Circular ducting – metal

	<p>Spigot without lip seal</p> <ul style="list-style-type: none"> <li>■ Plug-in mounting on ducting in accordance with EN 1506 or EN 13180.</li> <li>■ Affixing and sealing with ventilation strip, e. g. KLP180.</li> </ul> <p>When using heat-shrinkable tape, carefully heat up the plastic parts near the spigot.</p>
	<p>Spigot with optional lip seal</p> <ul style="list-style-type: none"> <li>■ Plug-in mounting on ducting in accordance with EN 1506 or EN 13180.</li> <li>■ Connect the spigot with the ducting, e. g. using drilling screws.</li> <li>■ No further sealing required.</li> </ul>
	<p>Spigot with optional steel flanges (galvanised steel)</p> <ul style="list-style-type: none"> <li>■ Matching flanges available as accessories</li> <li>■ Seal and screw connection M8 (to be provided by others)</li> <li>■ Dimensions and number of holes in accordance with EN 12220.</li> <li>■ Position the ducting exactly. Do not pull the distances together via the flange connection.</li> </ul>

### Circular duct – plastic

	<p>Plastic flanges (TVRK and TVLK)</p> <ul style="list-style-type: none"> <li>■ Matching flanges incl. seal available as accessories</li> <li>■ Screw connection M8 (to be provided by others)</li> <li>■ Dimensions and number of holes in accordance with EN 12220.</li> <li>■ Position the ducting exactly. Do not pull the distances together via the flange connection.</li> </ul>
	<p>Plastic spigot (TVRK and TVLK)</p> <ul style="list-style-type: none"> <li>■ Installation on ducting in accordance with DIN 8077             <ul style="list-style-type: none"> <li>– with clamp connectors</li> <li>– by plastic welding</li> </ul> </li> </ul>



### Rectangular duct



#### TVZ / TVA / TVM / TZ-/TA-Silenzio

- Connection to ducting with air duct connections.
- Make sure that the flange seal and screw connection M8x16 (to be provided by others) are properly installed.
- Position the ducting exactly. Do not pull the distances together via the air duct connections.

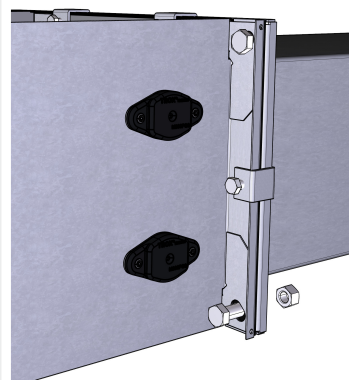

#### TVJ / TVT

- Connection to ducting with air duct connections.
- Make sure that the flange seal and screw connection (to be provided by others) are properly installed.
- If necessary, insert additional duct clamps.
- Position the ducting exactly. Do not pull the distances together via the air duct connections.

### Insulation

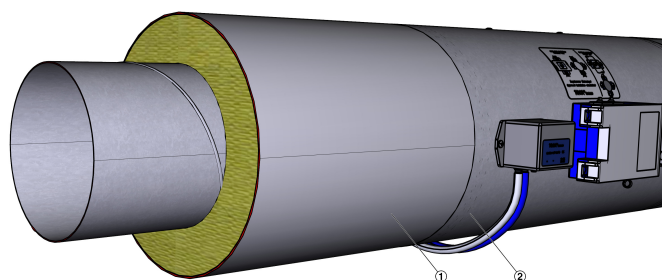

Fig. 29: Terminal unit with insulation, e.g. TVR-D

For VAV terminal units with acoustic cladding (Fig. 29/1), lead the insulation of the room-end ducting up to the acoustic cladding (Fig. 29/2) of the terminal unit.



#### **Retrofitting acoustic cladding**

*It is not possible to retrofit the factory acoustic cladding to the VAV terminal unit.*

## 5 Wiring

### Safety instructions

** DANGER!**

Danger of electric shock! Do not touch any live components! Electrical equipment carries a dangerous electrical voltage.

- Only skilled qualified electricians are allowed to work on the electrical system.
- Switch off the power supply before working on any electrical equipment.

### 5.1 Installation notes

The VAV terminal unit was manufactured and configured for each project. The control components are prewired at the factory. For installation of electrical control components, the supply voltage must be connected, and, if necessary, also signal or bus lines must be connected.

The connection is made according to the information on the control components or connection diagrams and the commissioning instructions for the respective control component, [www.trox.de](http://www.trox.de). These must be observed for project-specific wiring diagrams. The voltage ranges and terminal connections indicated on the control components must be observed!

**Personnel:**

- Skilled qualified electrician

Observe during installation:

- Legal and official regulations, in particular VDE guidelines
- Consideration of the technical connection conditions (TAB) of the local grid operators
- Wiring work for supply voltage and signal lines, to be provided by others
- The sizing and manufacture of connections and wiring provided by others must be carried out in accordance with the recognised regulations of electrical engineering.
- Comply with wiring guidelines and project-specific circuit diagrams of the control components.
- The electrical connection may only be made after complete installation of the control unit.
- For control components with 24 V supply only supply via safety transformer
- If several volume flow rate controllers are connected to one 24 V network, it is important to ensure that a common neutral or ground wire is used and that this is not connected to any other wiring.
- Suitable wire clamping brackets must be provided for all connecting cables.
- The control component does not contain any parts that can be replaced or repaired by the user and is only allowed to be opened by the manufacturer.



## 6 Commissioning and operation

### 6.1 Commissioning



#### Code of good practice for commissioning

Commissioning is governed by the standard "DIN EN 12599 Testing and measuring procedures for the transfer of installed ventilation and air conditioning systems", and, if applicable, contractually agreed services between HVAC contractors, system owners and installation engineers. The standard describes the essential commissioning steps of the completeness check, function check, function measurement as well as report generation and handover.

#### Factory calibration

TROX VAV terminal units are prepared, calibrated and tested at the factory with regard to air distribution technology. The commissioned operating parameters are also set. Once the electrical or pneumatic connections have been correctly installed and made, the terminal unit is ready for operation.

#### Exceptions:

- VAV terminal units with control component of the Easy type
  - Set operating parameters  $V_{min}$  and  $V_{max}$  on potentiometers (screwdriver required).
- Subsequent volume flow adjustments
  - Subsequent adjustments to the volume flow rate operating range may require manufacturer-specific adjustment devices or PC software, depending on the control component.
- Network integration
  - VAV terminal units with bus compatible control components may require integration into the building's network infrastructure to be performed by others (network commissioning).
- Special constructions
  - VAV terminal units without standardised control components (e.g. special versions) may require parameterisation or network integration to be performed by others. Manufacturer-specific tools such as adjustment devices or software packages and associated interface adapters may be required for this.

#### Carrying out the functional test

Prerequisites for the functional test

- Terminal unit has been correctly installed in the ducting system:

- Airflow direction, according to airflow direction arrows ↪ Chapter 4.4 'Direction of airflow' on page 15
  - Upstream conditions correct, ↪ Chapter 4.5 'Upstream conditions' on page 16
  - Electrical or pneumatic connections have been correctly installed and tested.
  - Ventilation and air conditioning system is in operation (fans running).
  - Supply voltage or the compressed air supply is switched on.
  - Measuring hoses between differential pressure sensor and pressure transducer are undamaged and kink-free.
1. ▶ Check installation orientation and carry out zero point correction, see instructions for the control component.



#### Installation orientation and zero point correction

Only required for control components with static diaphragm pressure transducer. Control components with static diaphragm pressure transducers can be identified by the installation orientation sticker ↪ Fig. 6.

2. ▶ Compare volume flow rate actual value signal with setpoint value signal. The setpoint value signal can be variable or constant, depending on the intended application.
3. ▶ Check damper blade positions:
  - Damper blade in control position
  - Door open
  - Door closed
4. ▶ Check override control functions
5. ▶ Further function tests on the VAV terminal unit can only be carried out if it is known which control component has been fitted.

Information on this can be found in the documentation of the TROX control components or in the product information of the control component manufacturer.

### 6.2 Operation

Once commissioning has been completed, the controller will operate independently and require no intervention from the system owner.

Depending on the area of application of the air terminal unit, test specifications and intervals may have to be observed; for example, when used on fume cupboards, an annual functional test must be carried out and documented.

In case of a malfunction, decommission the terminal unit and have it repaired before commissioning it again.

## 6.3 Volume flow rate measurement

For testing the volume flow rate or differential pressure transducer, the differential pressure  $\Delta p_w$  (effective pressure) can be measured directly at the differential pressure sensor of the air terminal unit by means of a pressure gauge (not on type TVE).

**Attention:** During the measurement, the actuator of the control component must be switched off, e.g. by switching off the supply voltage.

The connection for the pressure gauge must be selected depending on the transmitter type (dynamic or static) of the fitted control component:

- Dynamic - Pressure measurement only directly at the differential pressure sensor of the terminal unit (parallel measurement can falsify the result).
- Static - Parallel measurement to the transducer of the control component with its hose connections attached; the measurement is performed at T-pieces inserted in the measuring hoses at the factory.

### Alternative measurement point

Differential pressure measurement directly in the ducting as an alternative to the differential pressure sensor of the terminal unit requires a high degree of expertise and experience.

For sufficiently reliable differential pressure measurement results, a complex network measurement (gravity line method) and a final error propagation calculation in accordance with EN 12599 must be adhered to.

### 6.3.1 Volume flow rate calculation

The volume flow rate is calculated according to the following formula:

$$\dot{V} = C \times \sqrt{\Delta p_w} \quad [l/s]$$

$$\dot{V} = C \times \sqrt{\Delta p_w} \times 3,6 \quad [m^3/h]$$

Fig. 30: Calculation of the volume flow rate

- $\dot{V}$  Volume flow rate
- $\Delta p_w$  Measured effective pressure in Pascal [Pa]
- C Unit constant for air density  $\rho = 1.2 \text{ kg/m}^3$ ,  
 ↪ Chapter 9 'K values' on page 29

It should be noted that the volume flow rate determined depends on the current flow conditions in the ducting and that the measurement only corresponds to an instantaneous value without any averaging.

**Note:** It is not possible to calculate the volume flow rate according to this formula for the LCV and TVE types, as the unit constant C depends on the current blade angle.

## 7 Maintenance

### 7.1 System owner's responsibility

#### WARNING!

Only authorised specialist personnel are allowed to perform the described maintenance measures.

The system owner is responsible for maintenance. The system owner is responsible for creating a maintenance plan, for defining the maintenance goals, and for the functional reliability of the equipment.

The legal regulations must be observed during maintenance, e.g. the system owner is responsible for hygienic operation in accordance with VDI 6022.

### 7.2 Maintenance

The VAV terminal unit, the actuator and the electric/pneumatic control components are maintenance-free with regard to wear, but the VAV terminal unit must still be included in the regular cleaning of the ventilation system. Regular care and maintenance ensure operational readiness, functional reliability, and long service life of the VAV terminal unit.

### 7.3 Inspection measures

#### DANGER!

Danger of electric shock! Do not touch any live components! Electrical equipment carries a dangerous electrical voltage.

- Only skilled qualified electricians are allowed to work on the electrical system.
- Switch off the power supply before working on any electrical equipment.

#### CAUTION!

**Crushing hazard.**

The damper blade may suddenly open or close.

Switch off the voltage supply before you start working on the unit.

#### Personnel:

- Skilled qualified electrician

#### Protective equipment:

- Safety shoes

1. ▶ Remove any contamination that affects the function of the terminal unit, especially around sensor tubes and measuring probes.
2. ▶ Check all screws for firm seating and retighten them, if necessary.

3. ▶ Check electrical feeder cables for damage and firm seating in the terminals.
4. ▶ Adjust the zero point of the differential pressure transducer, see the documentation for the electronic control component.

#### Zero point correction

Only required for control components with static diaphragm pressure transducer. Control components with static diaphragm pressure transducers can be identified by the installation orientation sticker  Fig. 6.

5. ▶ Test the functions of the closed circuits (including volume flow rate) and, if necessary, correct the set operating parameters.
6. ▶ Check if the measured values are plausible.
7. ▶ Check special functions (override controls, alarm suppression on monitoring systems) and make corrections, if necessary.
8. ▶ Check sequence control functions (room balancing) and make corrections, if necessary.
9. ▶ Document maintenance measures and measurement results.

### 7.4 Repair

Repair work is only allowed to be carried out by specialist personnel or by the manufacturer. Only genuine replacement parts must be used.

### 7.5 Maintenance service

Regular maintenance by the TROX Technical Service is recommended in order to ensure operational readiness, functional reliability, and long service life of the unit.

The TROX Technical Service can establish the actual condition of the unit, adapt or correct it if necessary, and ensure that the unit is in proper condition after maintenance.

Necessary adjustments and parameter setting can be conducted as part of maintenance so that a high level of safety is always maintained.

## 8 Troubleshooting

Check the installation situation

- Accessibility to the VAV terminal unit and the control component sufficient?
- Specified airflow direction maintained? ↪ 4.4 'Direction of airflow' on page 15
- Required upstream section maintained? ↪ Chapter 4.5 'Upstream conditions' on page 16
- Installation orientation of control component maintained, depending on transmitter type of control component (observe installation orientation sticker ↪ on page 15)
- Differential pressure measuring hoses undamaged and kink-free?

Only for VAV terminal units for differential pressure control

- Selection of a suitable pressure measuring point
- Selection of a suitable pressure reference as comparison value (reference room with stable pressure conditions, with a constant atmospheric pressure)
- Select the measuring range of the pressure transducer with sufficient reserve. The measuring range must allow the detection of the setpoint pressure range plus an appropriate tolerance.
- The following applies in particular to room pressure control systems:
  - Sufficient cross section of the pressure measuring tubing, in particular when using ring ducts for the reference pressure
  - The pressure-controlled rooms must be sufficiently airtight to be able to build up the desired room pressure.
  - The pressure-controlled rooms must allow air transfer flow so that the room pressure can be regulated. (At least 10% of the total room extract air to air transfer flow.)
  - All doors and seals must be installed and holes must be closed in the walls in order to commission the rooms that are to be controlled.

Check system readiness

- Fan switched on?
- Sufficient pre charge pressure available at the VAV terminal unit, i.e. minimum differential pressure complied with in accordance with the data sheet?
- Fire dampers/shut-off devices opened in the duct section?

Check control component (for additional details, see commissioning instructions for control components)

- Error-free wiring and supply voltage within tolerance zone?
- Characteristic curve of the setpoint value control input signal suitable for the control component or its parameterisation?

- Zero point correction performed on control components with static transducer?
- If necessary, adapt the actuators again (only required for certain control components)

Check control operation

- Setpoint control within the control range of the VAV terminal unit and its control component.
- Check operating point at  $V_{min}$ ; if necessary, temporarily disconnect external setpoint setting to prevent influence of external control input signal and only check the controller itself at operating point  $V_{min}$ .
- Check the operating point at  $V_{max}$ ; check the direction of rotation of the damper blade in each case.
- Check damper blade position relative to the setpoint value; if the damper blade is fully open, the setpoint value is not reached. This is an indicator for an inadequate differential pressure. Detection of the damper blade position, ↪ 3.3 'Position of the damper blade' on page 14.

### Room situation (pressure conditions and air transfer behaviour)

The overall situation in the room depends on many factors, in particular:

- Supply air volume flow rates and their tolerance zone
- Extract air volume flow rates and their tolerance zone
- Tightness of the room or size of air transfer openings – type of control components used (control speed) and their control input signal
- Type of the selected leading control concept, control based on volume flow rate or pressure

Note: The planning concept – and not the individual VAV terminal unit – is decisive for achieving compliance with the desired room situation. Even if the technical data of the installed volume flow controller is complied with, the desired room situation can only be achieved if the necessary components have been selected during the planning phase, taking into account the requirements.

## 9 K values

### Rounded VAV terminal units

Serie	ØD [mm]	C-Wert (-> l/s)
LVC 1)	125	–
LVC 1)	160	–
LVC 1)	200	–
LVC 1)	250	–
TVE 1)	125,00	–
TVE 1)	160,00	–
TVE 1)	200,00	–
TVE 1)	250,00	–
TVR	100	6,10
TVR	125	9,97
TVR	140	12,40
TVR	160	16,00
TVR	200	26,06
TVR	250	39,50
TVR	315	65,60
TVR	400	108,18
TVRK	125	8,60
TVRK	160	15,10
TVRK	200	24,30
TVRK	250	38,00
TVRK	315	62,00
TVRK	400	103,00
TVLK <sup>2)</sup> --> 2009	250-0	43,06
TVLK <sup>3)</sup> 2009 -->	250-0	38,33
TVLK	250-100	25,00
TVLK	250-110	24,31
TVLK	250-140	21,53
TVLK	250-160	13,33
TVLK	250-180	15,14
TVLK	250-D08	33,89
TVLK	250-D10	24,30
TVLK	250-D16	13,75
TVR-Ex	125	9,97
TVR-Ex	160	16,00
TVR-Ex	200	26,06
TVR-Ex	250	39,50
TVR-Ex	315	65,60
TVR-Ex	400	108,18

1) LVC, TVE: no calculation possible using K value

2) TVLK: with four parallel measuring tubes made before approx. 2009

3) TVLK: with four crossed measuring tubes made from approx. 2009 onwards

### Rectangular VAV terminal units

Serie	ØD [mm]	B [mm]	H [mm]	C-Wert (-> l/s)
TVJ	–	200	100	15,17
TVJ	–	300	100	22,75
TVJ	–	400	100	30,34
TVJ	–	500	100	37,92
TVJ	–	600	100	45,50
TVJ	–	200	200	30,34
TVJ	–	300	200	45,50
TVJ	–	400	200	60,67
TVJ	–	500	200	75,84
TVJ	–	600	200	91,01
TVJ	–	700	200	106,17
TVJ	–	800	200	121,34
TVJ	–	300	300	74,51
TVJ	–	400	300	99,35
TVJ	–	500	300	124,19
TVJ	–	600	300	149,03
TVJ	–	700	300	173,86
TVJ	–	800	300	198,70
TVJ	–	900	300	223,54
TVJ	–	1000	300	248,38
TVJ	–	400	400	138,03
TVJ	–	500	400	172,54
TVJ	–	600	400	207,05
TVJ	–	700	400	241,55
TVJ	–	800	400	276,06
TVJ	–	900	400	310,57
TVJ	–	1000	400	345,08
TVJ	–	500	500	200,03
TVJ	–	600	500	240,03
TVJ	–	700	500	280,04
TVJ	–	800	500	320,04
TVJ	–	900	500	360,05
TVJ	–	1000	500	400,06
TVJ	–	600	600	298,05
TVJ	–	700	600	347,73
TVJ	–	800	600	397,40
TVJ	–	900	600	447,08
TVJ	–	1000	600	496,76
TVJ	–	700	700	415,42
TVJ	–	800	700	474,76
TVJ	–	900	700	534,11
TVJ	–	1000	700	593,46
TVJ	–	800	800	552,12
TVJ	–	900	800	621,14
TVJ	–	1000	800	690,16
TVJ	–	900	900	708,17
TVJ	–	1000	900	786,86
TVJ	–	1000	1000	883,56

Serie	ØD [mm]	B [mm]	H [mm]	C-Wert (-> l/s)
TVT	-	200	100	15,17
TVT	-	300	100	22,75
TVT	-	400	100	30,34
TVT	-	500	100	37,92
TVT	-	600	100	45,50
TVT	-	200	200	30,34
TVT	-	300	200	45,50
TVT	-	400	200	60,67
TVT	-	500	200	75,84
TVT	-	600	200	91,01
TVT	-	700	200	106,17
TVT	-	800	200	121,34
TVT	-	300	300	74,51
TVT	-	400	300	99,35
TVT	-	500	300	124,19
TVT	-	600	300	149,03
TVT	-	700	300	173,86
TVT	-	800	300	198,70
TVT	-	900	300	223,54
TVT	-	1000	300	248,38
TVT	-	400	400	138,03
TVT	-	500	400	172,54
TVT	-	600	400	207,05
TVT	-	700	400	241,55
TVT	-	800	400	276,06
TVT	-	900	400	310,57
TVT	-	1000	400	345,08
TVT	-	500	500	200,03
TVT	-	600	500	240,03
TVT	-	700	500	280,04
TVT	-	800	500	320,04
TVT	-	900	500	360,05
TVT	-	1000	500	400,06
TVT	-	600	600	298,05
TVT	-	700	600	347,73
TVT	-	800	600	397,40
TVT	-	900	600	447,08
TVT	-	1000	600	496,76
TZ-Silenzio	125	-	-	11,80
TZ-Silenzio	160	-	-	18,61
TZ-Silenzio	200	-	-	26,39
TZ-Silenzio	250	-	-	33,33
TZ-Silenzio	315	-	-	56,11
TA-Silenzio	125	-	-	13,19
TA-Silenzio	160	-	-	19,86
TA-Silenzio	200	-	-	26,94
TA-Silenzio	250	-	-	36,39
TA-Silenzio	315	-	-	61,94

Serie	ØD [mm]	B [mm]	H [mm]	C-Wert (-> l/s)
TVZ	125	-	-	9,97
TVZ	140	-	-	12,40
TVZ	160	-	-	16,00
TVZ	200	-	-	26,06
TVZ	250	-	-	39,50
TVZ	315	-	-	65,60
TVZ	400	-	-	108,18
TVA	125	-	-	9,00
TVA	140	-	-	11,50
TVA	160	-	-	15,20
TVA	200	-	-	24,20
TVA	250	-	-	38,00
TVA	315	-	-	63,00
TVA	400	-	-	103,00
TVM-K	125	-	-	9,97
TVM-K	160	-	-	16,00
TVM-K	200	-	-	26,06
TVM-K	250	-	-	39,50
TVM-K	315	-	-	67,50
TVM-K	400	-	-	108,30
TVM-W	125	-	-	16,80
TVM-W	160	-	-	29,10
TVM-W	200	-	-	43,70
TVM-W	250	-	-	61,30
TVM-W	315	-	-	89,40
TVM-W	400	-	-	144,50

TVM-K: Cold air spigot

TVM-W: Hot air spigot



# 10 Control component/attachments

Code	Controlled variable	Differential pressure transducer	Actuator	LVC	TVE	TVR	TVJ	TVT	TZ-Silenzio	TA-Silenzio	TVZ	TVA	TVM	TVRK	TVLK
<b>Easy controller</b>		<b>Dynamic</b>													
Easy	V	Integral	Slow running, integrated	•	•	•	•	•	•	•	•	•	•		
<b>Compact controller</b>		<b>Dynamic</b>													
BC0	V	Integral	Slow running, integrated	•		•	•	•	•	•	•	•	•		
BL0	V	Integral	Slow running, integrated			•	•	•	•	•	•	•	•		
BM0	V	Integral	Slow running, integrated			•	•	•	•	•	•	•	•		
BM0-J6	V	Integral	Slow running, integrated			•	•	•	•	•	•	•	•		
XB0	V	Integral	Slow running, integrated		•	•	•	•	•	•	•	•	•		
LN0	V	Integral	Slow running, integrated			•	•	•	•	•	•	•	•		
LK0	V	Integral	Slow running, integrated			•	•	•	•	•	•	•	•		
XM0	V	Integral	Slow running, integrated		•										
XM0-J6	V	Integral	Slow running, integrated		•										
<b>Compact controller</b>		<b>Static</b>													
SA0	V	Integral	Slow running, integrated			•	•	•	•	•	•	•	•		
SC0	V	Integral	Fast-running, integral			•	•	•	•	•	•	•	•		
XD0	V	Integral	Slow running, integrated			•	•	•	•	•	•	•	•		
XS0	V	Integral	Slow running, integrated		•										
XS0-J6	V	Integral	Slow running, integrated		•										
XF0	Δp	Integrated 600 Pa	Slow running, integrated			•	•	•	•	•	•	•	•		
<b>Universal controller</b>		<b>Dynamic</b>													
B11	V	Integral	Slow running, separately					•							
B13	V	Integral	Slow running, separately				•	•							
B1B	V	Integral	Spring return actuator, separate			•	•	•	•	•	•	•	•		
XB4	V	Integral	Spring return actuator, separate			•	•	•	•	•	•	•	•		
<b>Universal controller</b>		<b>Static</b>													
BP1	V	Separately	Slow running, separately					•							
BP3	V	Separately	Slow running, separately			•	•	•	•	•	•	•	•		•
BPB	V	Separately	Spring return actuator, separate			•	•	•	•	•	•	•	•		•
BPG	V	Separately	Fast running, separately			•	•	•	•	•	•	•	•		•
BB1	V	Separately	Fast running, separately					•							
BB3	V	Separately	Slow running, separately			•	•	•	•	•	•	•	•		•
BBB	V	Separately	Spring return actuator, separate			•	•	•	•	•	•	•	•		•
XD4	V	Integral	Spring return actuator, separate			•	•	•	•	•	•	•	•		•
BR1	Δp	Separately 100 Pa	Slow running, separately					•							
BR3	Δp	Separately 100 Pa	Slow running, separately			•	•		•	•	•	•	•		•
BRB	Δp	Separately 100 Pa	Spring return actuator, separate			•	•	•	•	•	•	•	•		•
BRG	Δp	Separately 100 Pa	Fast running, separately			•	•	•	•	•	•	•	•		•
BS1	Δp	Separately 600 Pa	Slow running, separately					•							
BS3	Δp	Separately 600 Pa	Slow running, separately			•	•		•	•	•	•	•		•
BSB	Δp	Separately 600 Pa	Spring return actuator, separate			•	•	•	•	•	•	•	•		•
BSG	Δp	Separately 600 Pa	Fast running, separately			•	•	•	•	•	•	•	•		•
BG1	Δp	Separately 100 Pa	Slow running, separately					•							
BG3	Δp	Separately 100 Pa	Slow running, separately			•	•		•	•	•	•	•		•
BGB	Δp	Separately 100 Pa	Spring return actuator, separate			•	•	•	•	•	•	•	•		•
BH1	Δp	Separately 600 Pa	Slow running, separately					•							
BH3	Δp	Separately 600 Pa	Slow running, separately			•	•		•	•	•	•	•		•
BHB	Δp	Separately 600 Pa	Spring return actuator, separate			•	•		•	•	•	•	•		•
XF4	Δp	Integrated, 600 Pa	Spring return actuator, separate			•	•	•	•	•	•	•	•		•
TUN	V, Δp	V = integrated, Δp= separately	Slow running, separately			•	•	•	•	•	•	•	•		•
TUNF	V, Δp	V = integrated, Δp= separately	Spring return actuator, separate			•	•	•	•	•	•	•	•		•
TUS	V, Δp	V = integrated, Δp= separately	Fast running, separately			•	•	•	•	•	•	•	•		•
<b>EASYLAB</b>		<b>Static</b>													
ELAB	V, Δp	V = integrated, Δp= separately	Fast running, separately			•	•	•	•	•	•	•	•		•
ELAB	V, Δp	V = integrated, Δp= separately	Fast-running, digital, separate			•	•	•	•	•	•	•	•		•





## **11 Declaration of conformity**

## Declaration of incorporation

according to the EU Machinery Directive 2006/42/EC, Annex II 1. B  
for partly completed machinery

The art of handling air

### Manufacturer

TROX GmbH  
Heinrich-Trox-Platz  
DE - 47504 Neukirchen-Vluyn

### Person established in the Community authorised to compile the relevant technical documentation

Jan Heymann, TROX GmbH

### Description and identification of the partly completed machinery

<b>Product / Article</b>	VAV controller
<b>Type</b>	TVE, TVR, TVJ, TVT, TZ/TA-Silenzio, TVZ/TVA, TVM, TVRK, TVLK, LVC
<b>Function</b>	Controller for flow and / or pressure control in ventilation systems

**It is declared that the following essential requirements of the Machinery Directive 2006/42/EC have been fulfilled:**

It is also declared that the relevant technical documentation has been compiled in accordance with part B of Annex VII.

**It is expressly declared that the partly completed machinery fulfils all relevant provisions of the following EU Directives or Regulations:**

2006/42/EC	Directive 2006/42/EC of the European Parliament and of the Council of 17 May 2006 on machinery, and amending Directive 95/16/EC (recast) (1)
2014/30/EU	Directive 2014/30/EU of the European Parliament and of the Council of 26 February 2014 on the harmonisation of the laws of the Member States relating to electromagnetic compatibility (recast)
2014/35/EU	Directive 2014/35/EU of the European Parliament and of the Council of 26 February 2014 on the harmonisation of the laws of the Member States relating to the making available on the market of electrical equipment designed for use within certain voltage limits

### Reference to the harmonised standards used, as referred to in Article 7 (2):

EN ISO 12100:2010-11	Safety of machinery - General principles for design - Risk assessment and risk reduction (ISO 12100:2010)
----------------------	---

The manufacturer or his authorised representative undertake to transmit, in response to a reasoned request by the national authorities, relevant information on the partly completed machinery. This transmission takes place  
by post

This does not affect the intellectual property rights!

**Important note! The partly completed machinery must not be put into service until the final machinery into which it is to be incorporated has been declared in conformity with the provisions of this Directive, where appropriate.**

Neukirchen-Vluyn, 11.06.2019

Heymann Jan  
CE-Beauftragter



# TROX<sup>®</sup> TECHNİK

The art of handling air

**TROX GmbH**  
Heinrich-Trox-Platz  
47504 Neukirchen-Vluyn  
Germany

+49 (0) 2845 202-0  
+49 (0) 2845 202-265  
E-mail: [trox@trox.de](mailto:trox@trox.de)  
[www.trox.de](http://www.trox.de)

© TROX GmbH 2018