

Swirl Diffuser

- Type VD
- adjustable, for installation heights ≥ 3.80 m



TROX[®] **TECHNIK**

TROX GmbH
Heinrich-Trox-Platz
D-47504 Neukirchen-Vluyn

Telephone +49/28 45/2 02-0
Telefax +49/28 45/2 02-2 65
e-mail trox@trox.de
www.troxtechnik.com

Contents · Description

Description	2
Construction · Dimensions	3
Materials	3
Installation · Weight	4
Nomenclature	5
Technical Data	5
Acoustic Data	6
Quick Selection	7
Aerodynamic Data for Heating	7
Aerodynamic Data VD 425 and 600	8
Aerodynamic Data VD 775 and 1050	9
Order Details	10

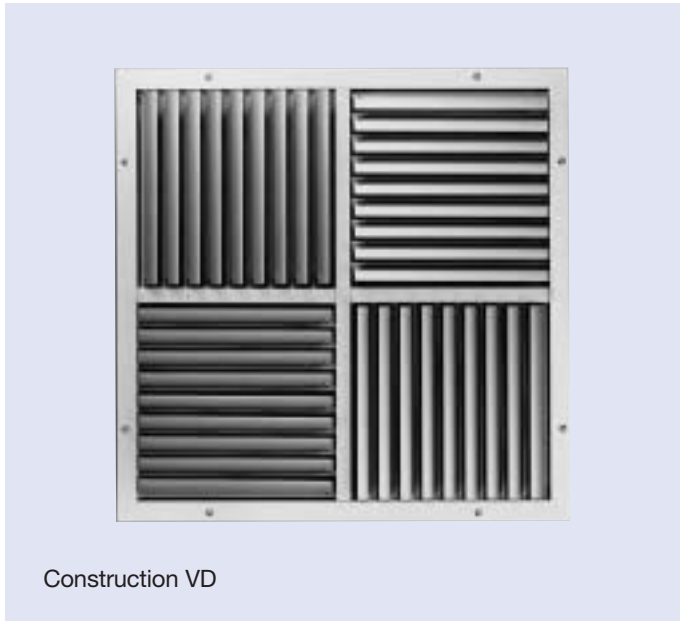

Construction VD

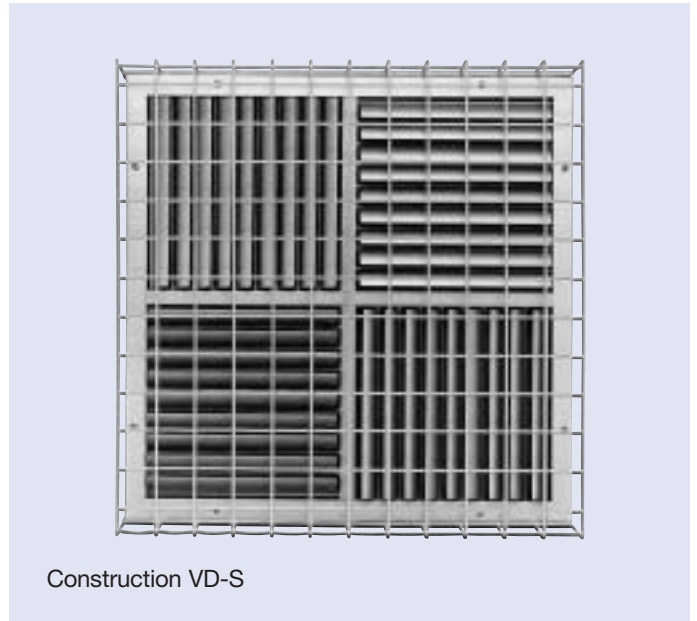

Construction VD-S

Description

Due to changing thermal loads in a space, air entering the space can either be cooling, isothermal or heating. The type VD swirl diffusers can provide an optimum ventilation of the occupied zone with excellent comfort characteristics. This is achieved by varying the adjustable air pattern control blades between horizontal, angled and vertical discharge as the operation changes between cooling and heating modes.

Due to the large volume flow range, they can be used for both, industrial and comfort conditioning applications.

These diffusers can be used in spaces with large floor to ceiling heights (e.g. industrial workshops, airports, theatres and banks), however, they can also be used for lower mounting heights below ≥ 3.8 m (e.g. conference rooms). In all cases they are particularly appropriate when the supply air temperature differential varies between -10K to $+15\text{K}$.

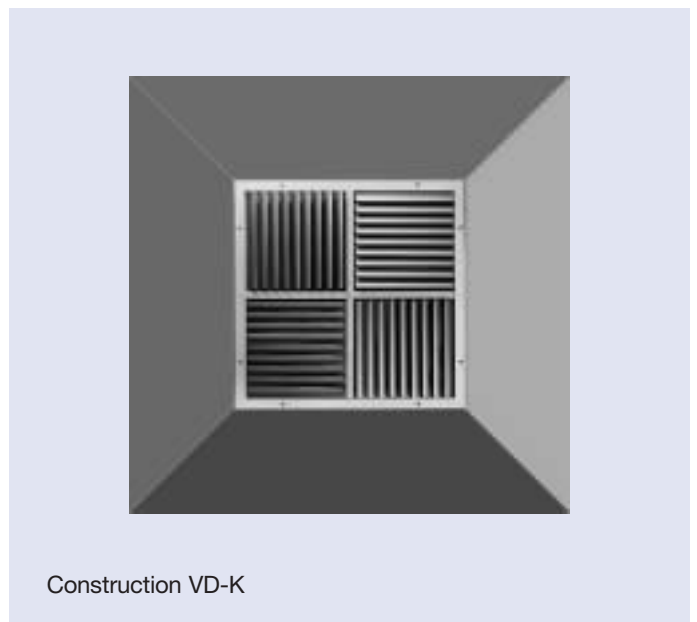

Construction VD-K

Construction · Dimensions · Materials

Construction

Depending on installation, all type VD diffusers can be supplied with top or side entry plenum boxes. The aluminium face plate is mounted on the plenum with visible screw fixings through the border. The face plate with control actuator and linkage comes as an integral assembly which is easily demountable from below. The air control blades can be adjusted either manually by using an electric actuator. For use in sports halls, a protection grid can be supplied as an optional extra.

Materials

Diffuser face made of extruded aluminium sections. Standard finish is natural anodised, E6-C-0.

Plenum box, actuator mounting and collar made of galvanised sheet steel.

The protection grid is made of formed steel rod. Surface is powder coated pure white (RAL 9010).

Other colours are optional for all visible surfaces.

Dimensions in mm

Size	□ B	∅D	G1	G2	H1	H2	J	K1	K2	□ M	P
425	425	248	31	46	500	500	335	449	404	833	325
600	600	313	33	48	550	550	353	624	604	1003	500
775	775	448	45	60	550	750	498	799	754	1171	675
1050	1050	498	45	60	600	800	523	1074	1054	1451	950

VD-V... with top entry spigot

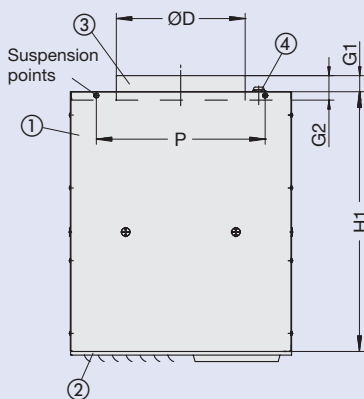

VD-H... with side entry spigot

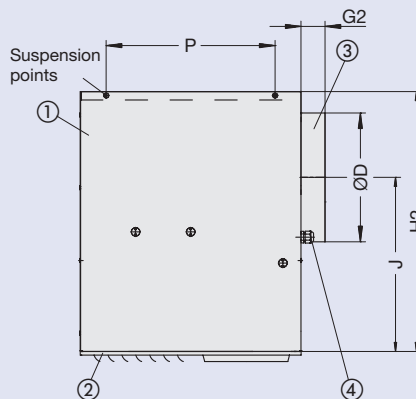

- ① Plenum box
- ② Diffuser face
- ③ Primary air spigot
- ④ Cable clamp (only for constructions E1 to E3)
- ⑤ Protection grid
- ⑥ Collar

* For variants with plenum box only

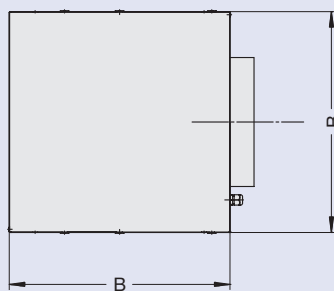
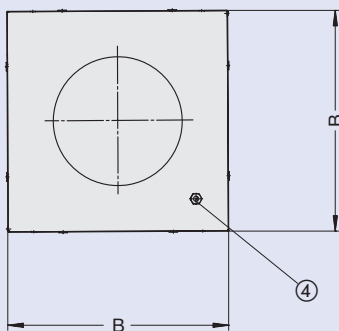

VD-V-K... and VD-H-K... with collar *

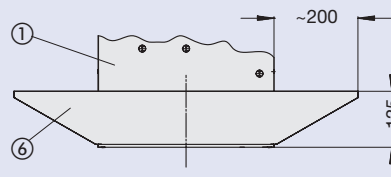

VD-V-S... and VD-H-S... with protection grid *

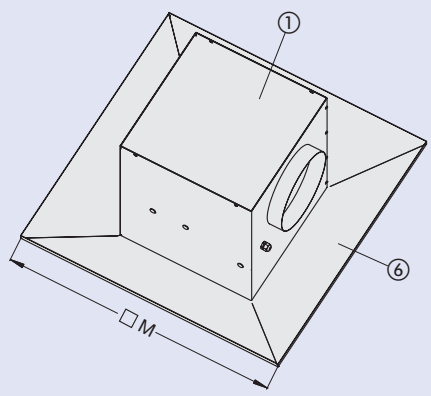
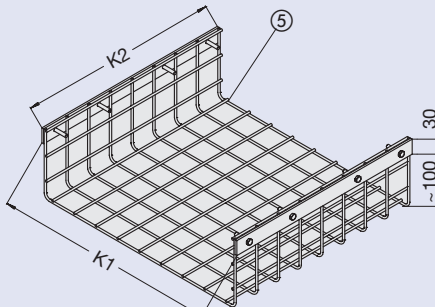
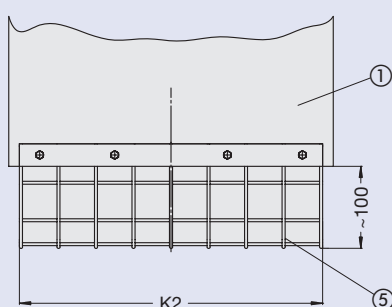

Installation · Weight

Installation

Swirl diffusers type VD can be installed flush with ceiling as well as freely suspended, due to their versatile characteristics.

With a flush installation in open raster ceilings, the same flow conditions result as with a freely suspended situation.

A continuous adjustment of the direction of air flow can be made using an electrical actuator; see diffuser arrangement, figure 1.

TROX-TDC can be used for the temperature-independent actuation of the heating or cooling mode.

Construction	Weight in kg			
	Size			
	425	600	775	1050
VD-0	4	7	9	17
VD-0-E1...-E3	6	9	12	23
VD-V	11	19	29	51
VD-H	11	19	34	57
Collar -K	3	6	7	8
Protection grid-S	3	6	7	8

Figure 1

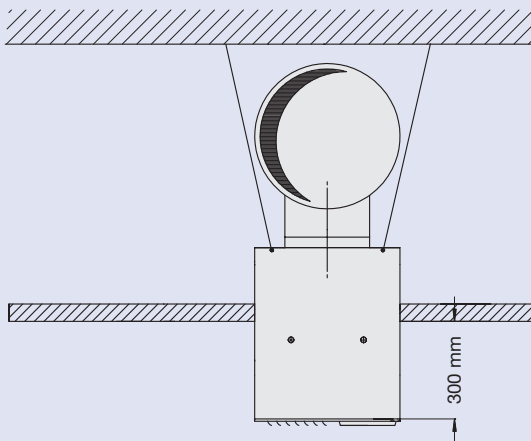

Installation of the face 300 mm below a continuous closed ceiling is required to obtain a fully angled discharge.

Figure 2

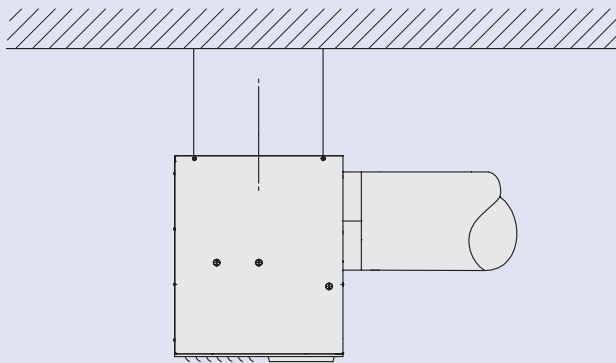

Freely suspended: e.g. suited for industrial use

Figure 3

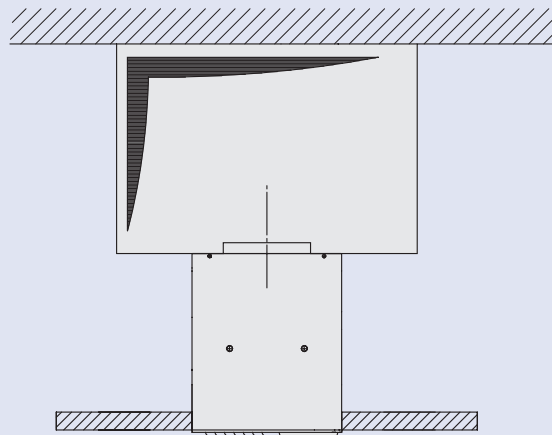

Flush installation in continuous closed ceiling provides two fixed directions of discharge – horizontal and vertical.

Figure 4

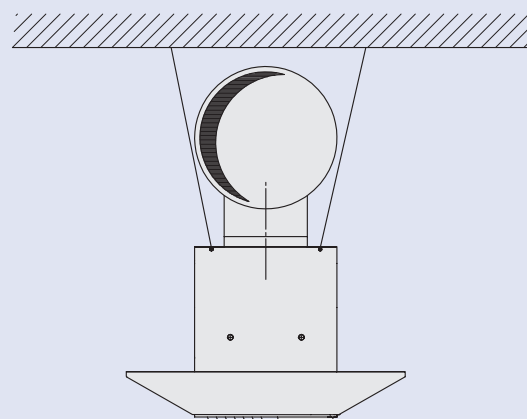

Freely suspended e.g. for use in comfort conditioning with surrounding collar to provide horizontal discharge.

Nomenclature · Technical Data

Nomenclature

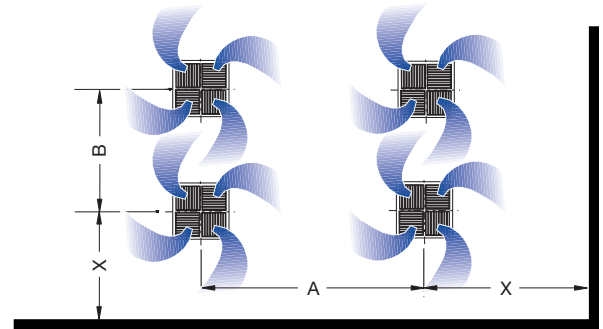
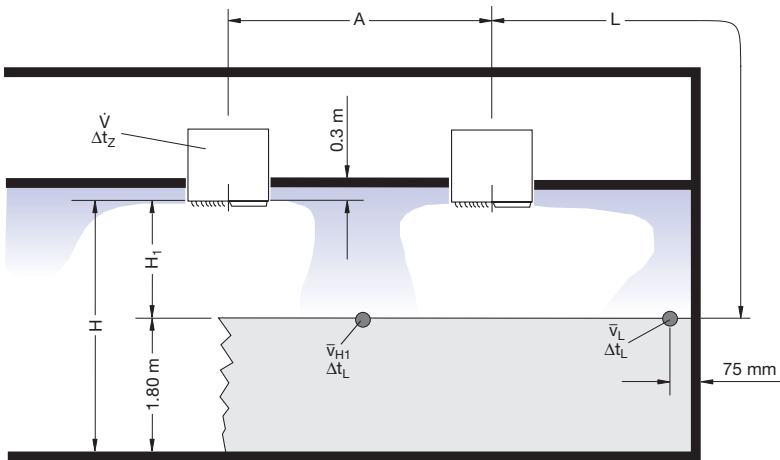

- \dot{V} in l/s or in m³/h: Supply air volume per diffuser
- A in m: Spacing between two diffusers
- H_1 in m: Distance between diffuser face and occupied zone
- \bar{v}_{H1} in m/s: Time average air velocity between two diffusers at distance H_1 from diffuser face
- L in m: Distance from diffuser centre to wall + H_1
- \bar{v}_L in m/s: Time average air velocity at wall
- L_{max} in m: Max. penetration of supply air when heating
- Δt_z in K: Temperature difference between supply air and room air
- Δt_L in K: Temperature difference between core and room at distance $L = A/2 + H_1$ or L to the wall
- A_{eff} in m²: Effective free area
- Δp_t in Pa: Total pressure drop
- L_{WA} in dB(A): A-weighted sound power level
- L_{WNC} : NC rating of sound power level
- L_{WNR} : $L_{WNR} = L_{WNC} + 1$

Effective free area		
Size	A_{eff} in m ²	
	Horizontal Discharge	Vertical Discharge
425	0,0307	0,0781
600	0,0685	0,1819
775	0,1242	0,3405
1050	0,2247	0,6358

Acoustic Data

Example

Data given: Type VD-V; Size 425

Volume flow per diffuser: $\dot{V} = 300$ l/s

Required: Sound power level and pressure drop

Diagram 2:

$\Delta p_t = 55$ Pa

$L_{WA} = 48$ dB(A)

$L_{WNC} = 43$ NC

- 1** Sound power and pressure drop
VD-H (with side entry spigot)
Correction to $L_{WNC} = L_{WA} - 4$ dB

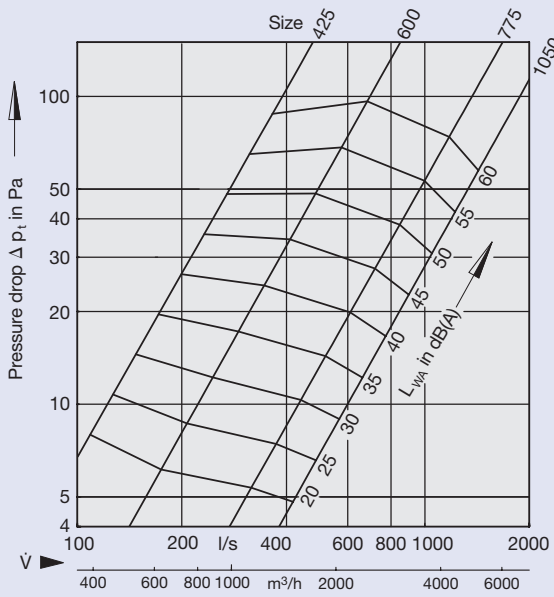

- 2** Sound power and pressure drop
VD-V (with top entry spigot)
Correction to $L_{WNC} = L_{WA} - 4.5$ dB

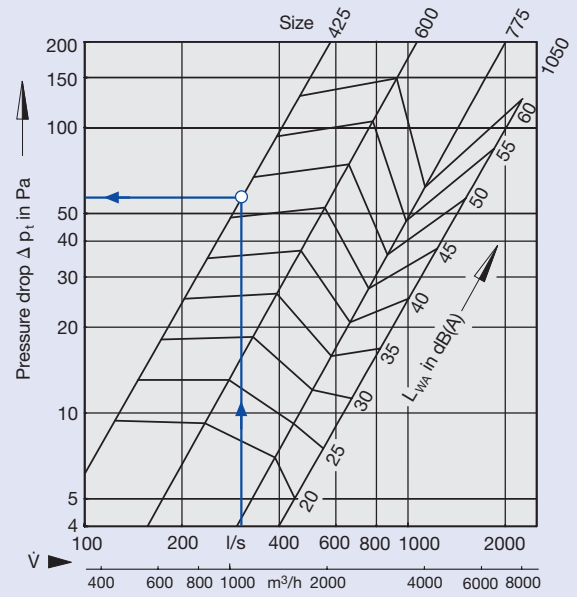

Quick Selection · Aerodynamic Data for Heating

Quick Selection					VD-V
Size	\dot{V}_{\min} in m ³ /h	\dot{V}_{\min} in l/s	\dot{V}_{\max} in m ³ /h	\dot{V}_{\max} in l/s	L _{WA} in dB(A)
425	300	83	900	250	45
600	750	208	1800	500	45
775	1300	361	2900	805	45
1050	2400	667	4000	1110	45

$$\text{m}^3/\text{h} = \text{l/s} \cdot 3.6$$

3 Max. supply air penetration 45°- discharge angle

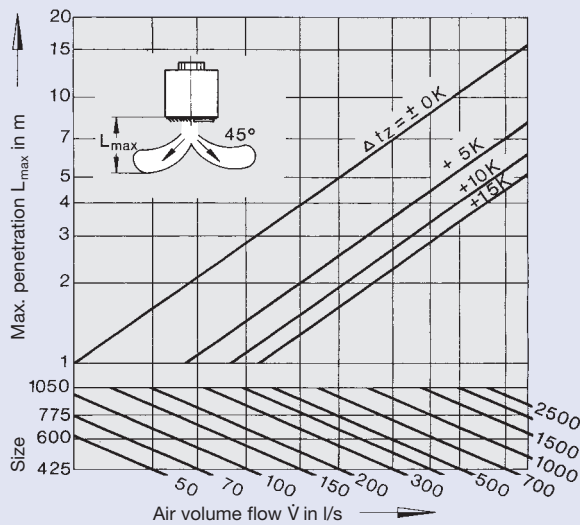

5 Max. supply air penetration 75°- discharge angle

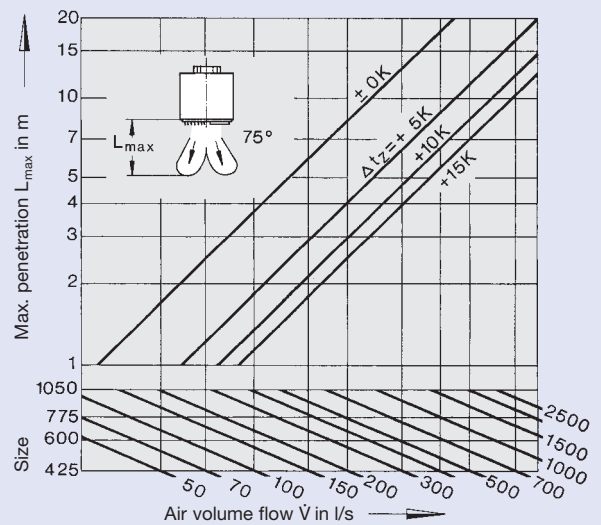

4 Max. supply air penetration 60°- discharge angle

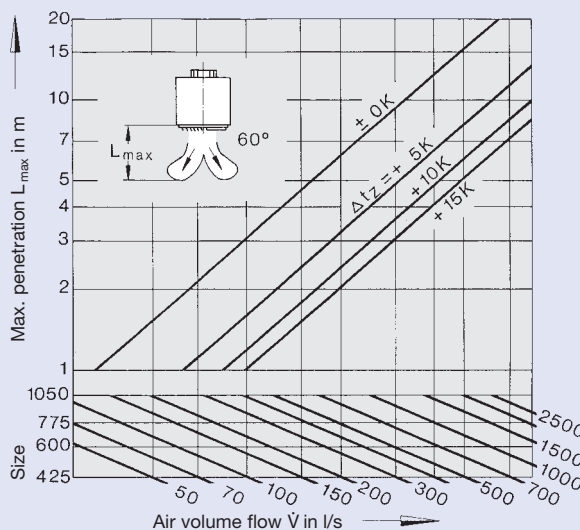

6 Max. supply air penetration vertical discharge

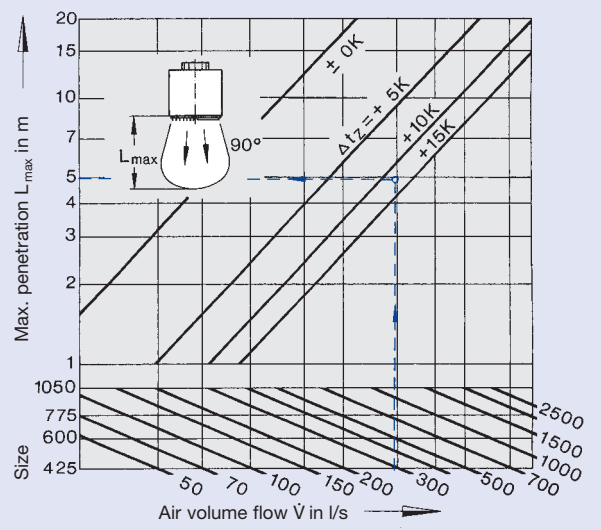

Aerodynamic Data VD 425 and VD 600

Example

Given:
 Supply air volume per diffuser $\dot{V} = 300 \text{ l/s}$
 Vertical duct connection, size 425 VD-V

Supply air temperature difference:
 horizontal, cooling $\Delta t_z = -8 \text{ K}$
 vertical, heating $\Delta t_z = +12 \text{ K}$
 Max. permissible sound power level $L_{WA} = 55 \text{ dB(A)}$
 Spacing between diffusers $A = 3.00 \text{ m}$
 Distance to wall = $A/2$ $L = \frac{3}{2} + (6-1.8) = 5.70 \text{ m}$
 Freely suspended installation with top entry spigot $H = 6.00 \text{ m}$

Resulting sound power level of 53 dB(A) is lower than the required value of 55 dB(A). For the calculation of the noise level in the room, correction for the number of diffusers and the room absorption must also be determined.

Diagram 6, Page 7: Max. supply air penetration, heating
 $\dot{V} = 300 \text{ l/s}$
 $\Delta t_z = +12 \text{ K}$
 $L_{max} = 4.80 \text{ m}$

Hence the warm airstream penetrates into the occupied zone during heating. This is necessary for the heating mode effectiveness. However, if the penetration depth still has to be reduced, the electrical signal to the actuator must be altered accordingly to achieve the required discharge angle.

Diagram 7: Air velocity in occupied zone, cooling
 $A = 3.00 \text{ m}$
 $H_1 = 6.00 - 1.80 = 4.20 \text{ m}$
 $\bar{v}_{H1} < 0.15 \text{ m/s}$

Correction:
 For flush installation in continuous ceiling \bar{v}_{H1} , \bar{v}_L and $\Delta t_L / \Delta t_z$ must be multiplied by 1.4.

7 Determination of spacing A Size 425

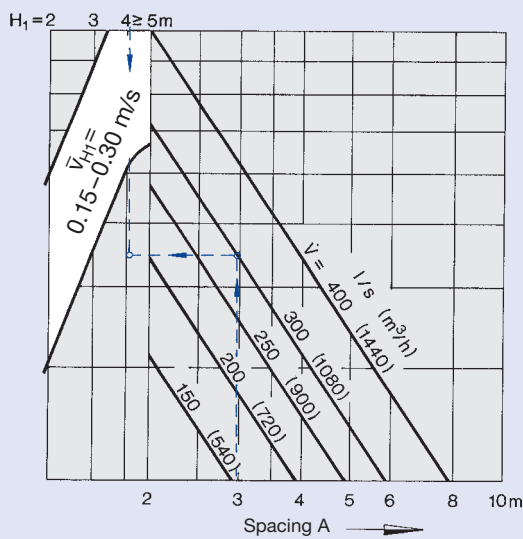

9 Determination of spacing A Size 600

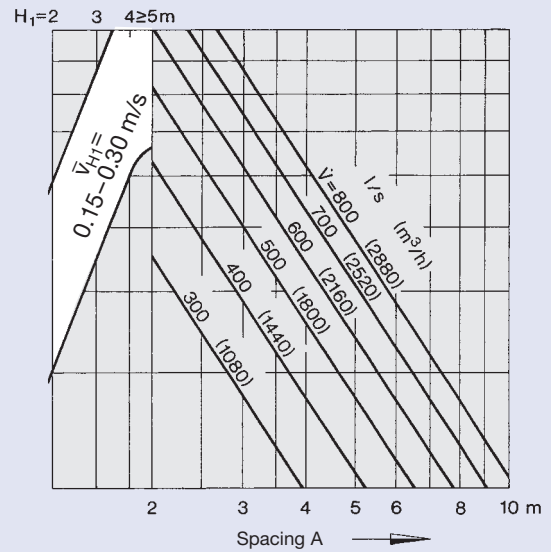

8 Max. core velocity at the wall and temperature quotient Size 425

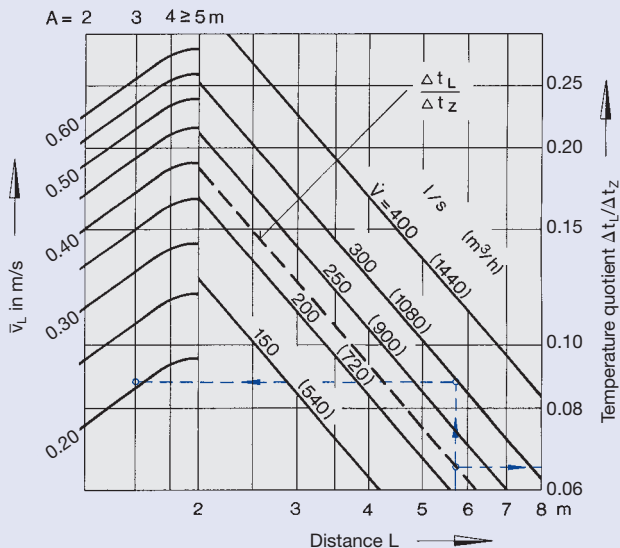

10 Max. core velocity at the wall and temperature quotient Size 600

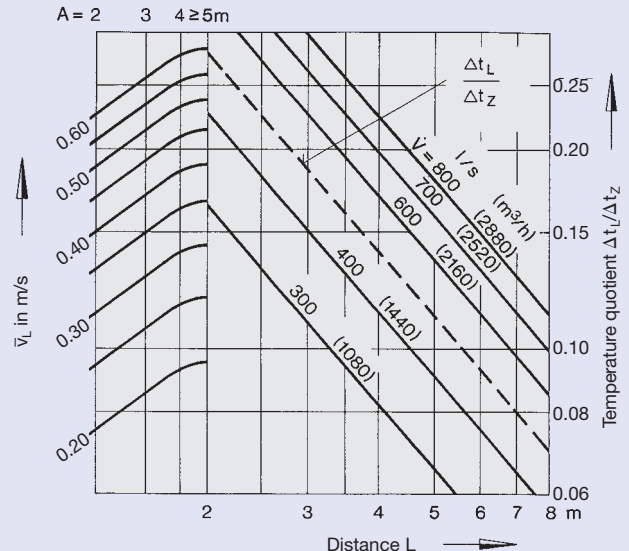

Aerodynamic Data VD 775 and VD 1050

Diagram 8, Page 8:

Max. core velocity at the wall, cooling

Diagrams are valid for cooling, horizontal discharge and freely suspended installation.

$L = A/2 + H_1$
 $L = 1.50 + 4.20 = 5.70 \text{ m}$

$\bar{v}_L = 0.21 \text{ m/s}$

$\Delta t_L / \Delta t_z = 0.065$

$\Delta t_L = -8 \cdot 0.065 = -0.52 \text{ K}$

Supply temperature difference: isothermal to -10 K
 Operation in warm air mode, see page 7

Result:

On the basis of the given data and complying with the required limiting values the selection of VD-V size 425 is appropriate.

Correction:

For flush installation in continuous ceiling \bar{v}_{H1} , \bar{v}_L and $\Delta t_L / \Delta t_z$ must be multiplied by 1.4.

11 Determination of spacing A Size 775
 $H_1 = 2 \quad 3 \quad 4 \geq 5 \text{ m}$

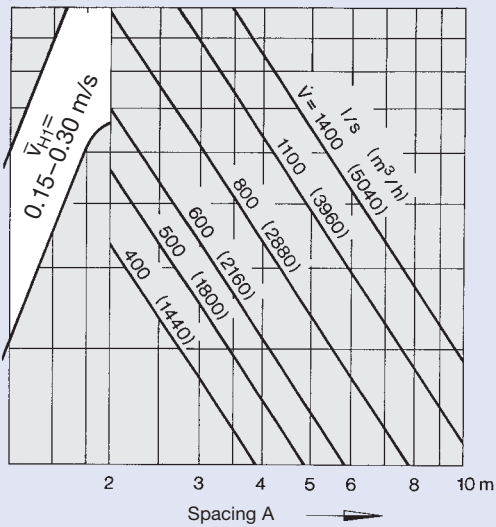

13 Determination of spacing A Size 1050
 $H_1 = 2 \quad 3 \quad 4 \geq 5 \text{ m}$

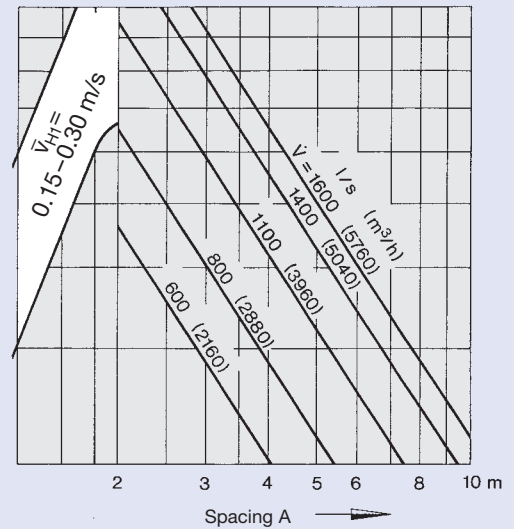

12 Max. core velocity at the wall and temperature quotient Size 775
 $A = 2 \quad 3 \quad 4 \geq 5 \text{ m}$

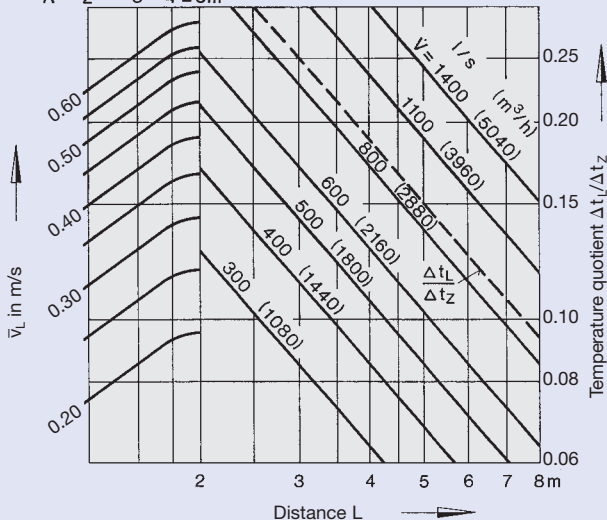

14 Max. core velocity at the wall and temperature quotient Size 1050
 $A = 2 \quad 3 \quad 4 \geq 5 \text{ m}$

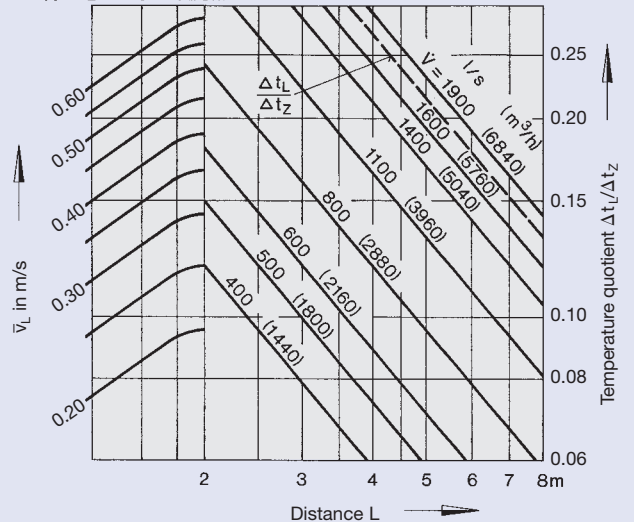

Order Details

Specification

Square swirl diffuser with adjustable blades, suitable for swirling horizontal air discharge.

By means of the adjustment of the diagonally disposed blade arrays, angled or vertical discharge can also be achieved. It is thus suitable for use at ceiling heights ≥ 3.8 m, particularly in the case of variation in supply air temperature differential

- VD-0: Diffuser face consisting of four blade arrays with manually adjustable air control blades.
- VD-V: As VD-0 but with plenum box, suspension points and side entry circular spigot.
- VD-H: As VD-0 but with plenum box, suspension points and top entry circular spigot.
- VD-...-E ...: With electrical actuator for the adjustment of two diagonally opposed blade arrays.
 - E1 – open-close control; 230 V, 50 Hz
 - E2 – open-close control; 24 V, 50 Hz
 - E3 – continuous control; 24 V, 50 Hz, Control signal 2 ... 10 V DC
- K: With collar for types VD-V and VD-H to provide horizontal discharge, supplied loose.
- S: With protection grid for sports halls, e.g. as a ball guard for types VD-V and VD-H, supplied loose.

Materials

Diffuser face made of extruded aluminium profiles, as standard natural anodised finish E6-C-0, alternatively with powder coat colour finish to RAL...

The plenum box is made of galvanised sheet steel.

Collar made of galvanised steel sheet, alternatively with powder coat colour finish to RAL...

Protection grid consists of formed steel rod, finish powder coated pure white RAL 9010, alternatively with powder coat colour finish to RAL...

Order Code

These codes do not need to be completed for standard products.

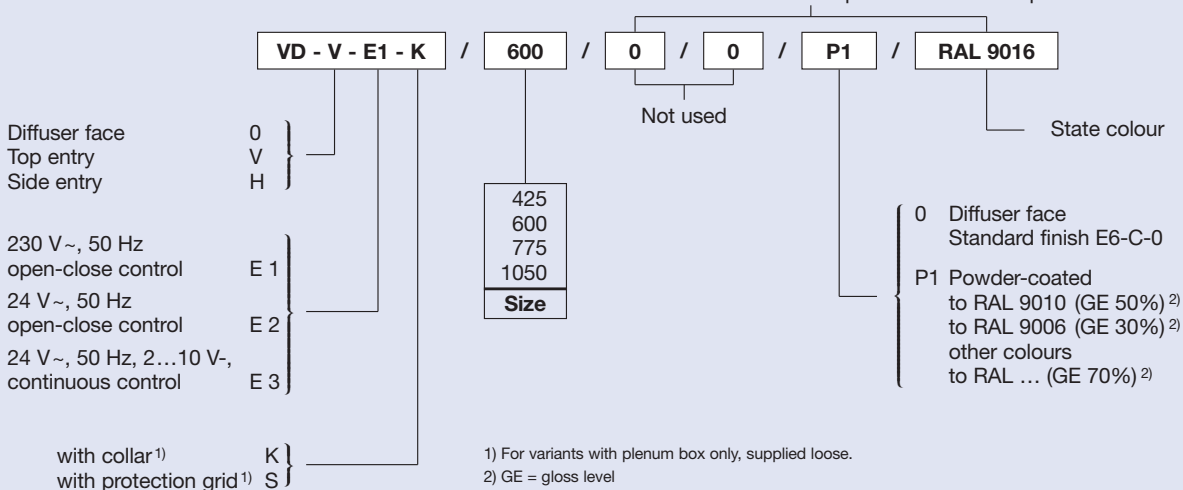

Order Example

Manufacturer: TROX
 Type: VD - V - E1 - K / 600 / 0 / 0 / P1 / 9016