

Designer Diffusers

Type ADD

The creative element
for ceilings in comfort conditioning



TROX[®] TECHNİK

TROX GmbH
Heinrich-Trox-Platz
D-47504 Neukirchen-Vluyn

Telephone +49/28 45/2 02-0
Telefax +49/28 45/2 02-2 65
e-mail trox@trox.de
www.troxtechnik.com

Contents · Description

Description _____	2	Nomenclature _____	5
Dimensions · Construction _____	3	Acoustic data _____	6
Materials _____	3	Aerodynamic data _____	14
Installation · Fixing details _____	4	Order details _____	17

ADD-Q



ADD-R



**Different versions of the Designer face plate are available on request!
They are similar to those below.**

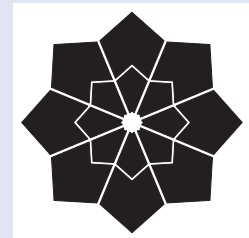
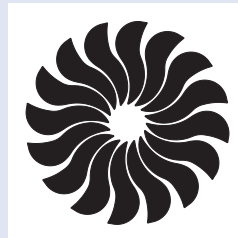
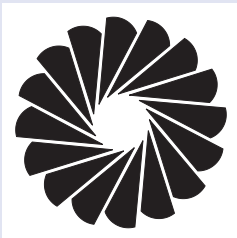

Designer Diffusers Type ADD are recommended for the supply and extract air application.

The attractive feature is the special architect-designed diffuser face. It is superior to other diffusers because of its high free area and the rear control blades, yet it performs well all the functions of a swirl diffuser.

Depending on the requirements of the architect the diffuser can be provided with a circular or square faceplate. Air connection is by means of a plenum box with top or side spigots.

The swirl and horizontal discharge of the supply air guarantees high induction, which results in rapid reduction in jet temperature differential and velocity. To stabilize the supply air jet, all sizes must be installed flush with the ceiling.

The minimum distance from the diffuser face to the floor should be 2.60 m.

The diffusers are suitable for supply air temperature differentials of +10K to -10K.

Construction

Diffusers Type ADD for supply air comprise a circular or square designer faceplate with continuous rear seal, a rear air control ring and a swirl unit.

The diffuser face can be fitted to or removed from the plenum by means of a centre fixing screw. The screw head is fitted with a decorative cap. The plenum box can be supplied with top or side entry spigot and on request, with volume control damper and/or spigot lip seal.

The plenum is suspended by holes in the top flange or by means of brackets.

If required the plenum box can be provided with a test connection for measurement of reference pressure and volume control damper operated by sheathed cables to set flow rate.

Materials:

Galvanized sheet steel faceplate powder-coated white (RAL 9010, gloss level 50%), aluminium control ring, stove enamelled black (RAL 9005), galvanized sheet steel swirl unit, stove-enamelled black (RAL 9005), sheet steel plenum box, rubber lip seal.

Size	ØB	ØD	H ₁ min ³⁾	H ₂	K	ØP	ØR ₁	ØR ₂	ØR ₃	Q	AK code ¹⁾
250	143	123	200	220	266	202	250	192	138	248	AK019
300	199	158	200	250	290	258	300	248	194	298	AK020
400	255	198	200	295	372	314	400	304	250	398	AK021
450	311	248	230	345	476	362	450	360	306	448	AK022
500	367	248	230	345	476	426	500	416	362	498	AK023
600	479	313	260	410	590	578	600	528	474	598	AK025
625 ²⁾	479	313	260	410	590	578	-	528	474	623	AK025

1) Only applies to ADD-...-H!

2) Does not apply for ADD-R!

3) H₁max = H₁min + 30!

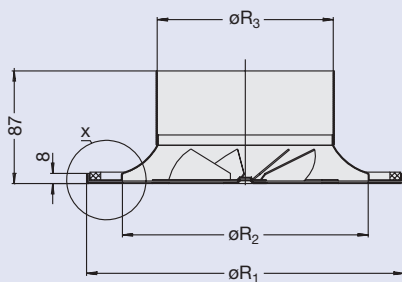

Detail X

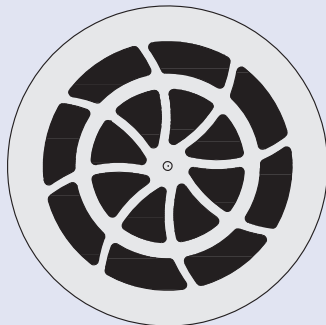
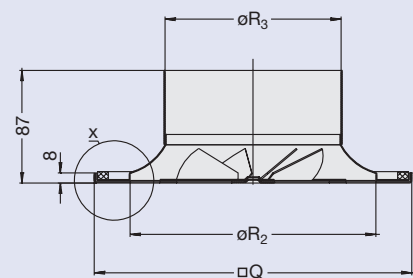
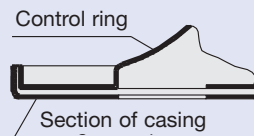

ADD-R

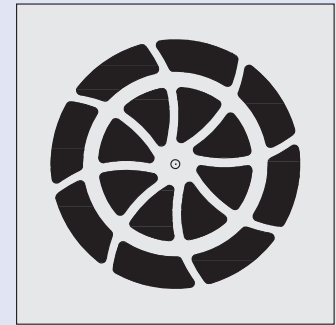

ADD-Q

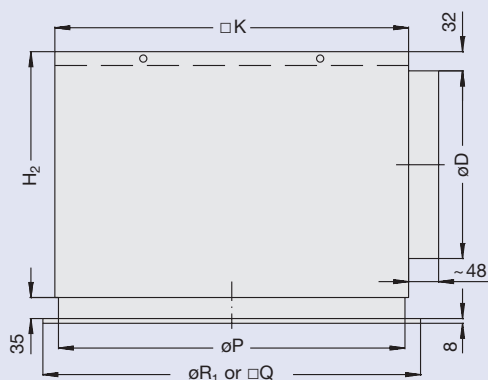

ADD with plenum box – side entry spigot
ADD-...-ZH/AH

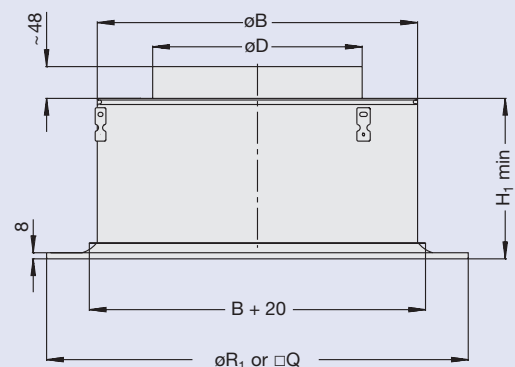

ADD with plenum box – top entry spigot
ADD-...-ZV/AV

Installation · Fixing Details

Installation · Fixing Details

All versions and sizes are designed for installation in continuous, suspended ceilings. Where plenum boxes are used the whole unit can be suspended on wires or rods using the holes in the top of the plenum return edges or hanging brackets provided.

The seal, which is supplied for side entry configuration, must be glued to the reverse edge of the plenum box on site. The diffuser face is installed with a centre fixing bolt locating in a bridge in the plenum. A decorative cap is pressed over the head of the fixing bolt.

A stable air flow is also guaranteed when the diffuser is installed outside of a closed ceiling (freely suspended) provided that the surrounding edge is widened by >50mm. Please inquire in case of demand.

Determining the volume flow by Δp_w

With the option "MN" (volume flow setting with control cable and test nipple) – see order code.

The setting of required flow rate is simplified.

The reference pressure Δp_w is measured using a plastic tube to a standard manometer.

The relevant volume flow is determined from the characteristic $\dot{V} = f(\Delta p_w)$ enclosed with every plenum box.

If necessary cables ⑥ and ⑦ can be used to adjust butterfly damper in order to obtain the required volume flow.

When the measurement and the adjustment have been completed the tube and the cables are pushed behind the diffuser face.

Installation flush with ceiling

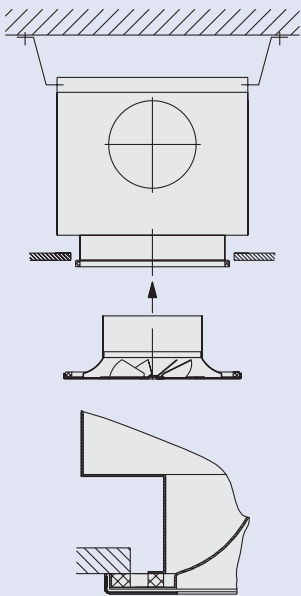

Diffuser face fixed by centre fixing bolt

Freely suspended

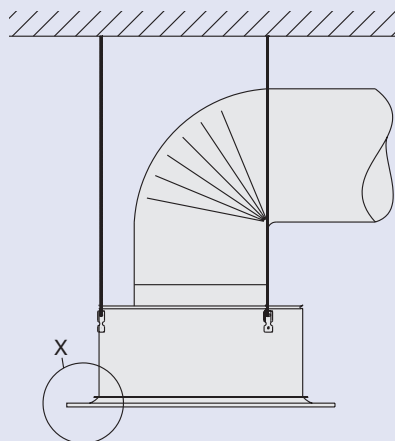

Installation using suspension brackets

Detail X

Measurement of reference pressure

Side entry plenum box

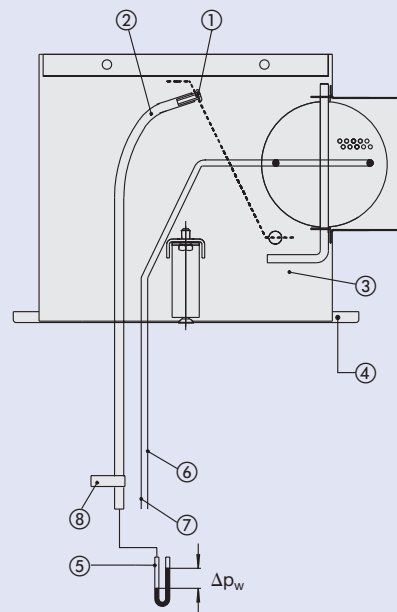

Measurement of reference pressure

Top entry plenum box

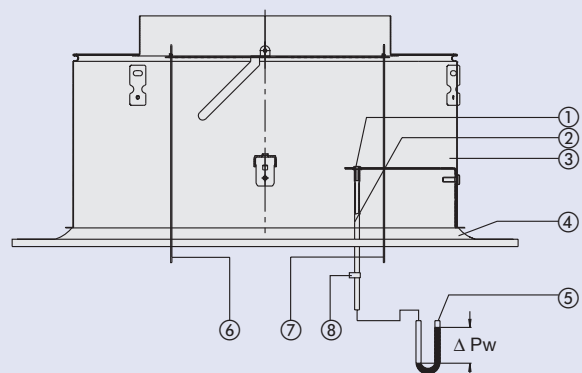

Installed with ceiling tiles

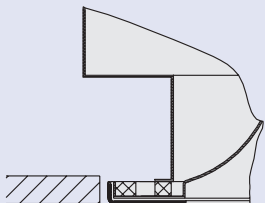

- ① Test nipple
- ② Plastic hose
- ③ Plenum tube
- ④ Diffuser face
- ⑤ Inclined manometer
- ⑥ Green cable to close butterfly damper
- ⑦ White cable to open butterfly damper
- ⑧ Plenum box code

Nomenclature

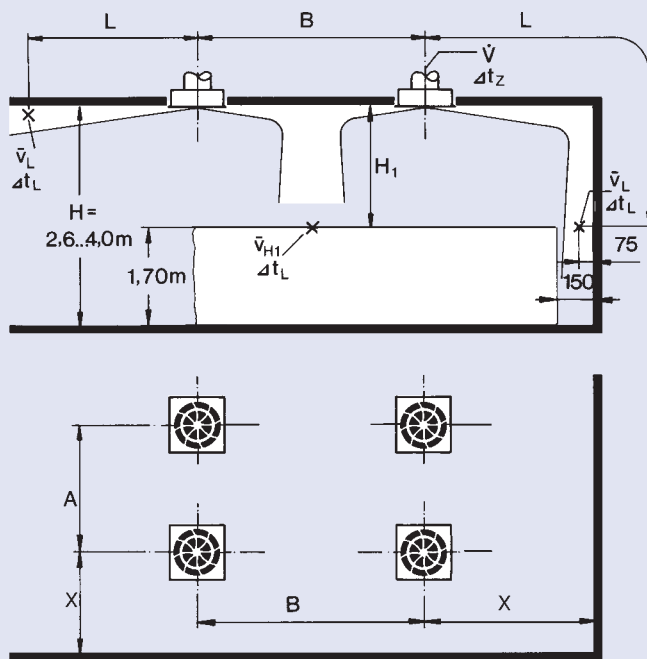

Nomenclature

- \dot{V} in l/s: Volume flow per diffuser
- \dot{V} in m³/h: Volume flow per diffuser
- A, B in m: Spacing between two diffusers
- X in m: Distance from centre of diffuser to wall
- H₁ in m: Distance between ceiling and occupied area
- \bar{v}_{H1} in m/s: Mean air velocity between two diffusers at distance from ceiling H₁
- L in m: Distance horizontal + vertical (X + H₁) when discharging towards wall
- \bar{v}_L in m/s: Mean air velocity at wall
- Δt_z in K: Temperature difference between supply air and room air
- Δt_L in K: Difference between core and room temperature at distance
 - $L = A/2 + H_1$
 - $L = B/2 + H_1$
 - $L = X + H_1$
- A_{eff} in m²: Effective outlet area
- Δp_t in Pa: Total pressure drop (supply air)
- L_{WA} in dB(A): A-weighted sound power level
- L_{W NC}: NC rating of sound power level
- L_{W NR}: L_{W NR} = L_{W NC} + 2
- L_{pA}, L_{pNC}: A-weighting and NC rating respectively of sound pressure level
 - in room L_{pA} ≈ L_{WA} - 8 dB
 - L_{pNC} ≈ L_{W NC} - 8 dB
- ΔL in dB/oct: Relative sound power level with respect to L_{WA}
- L_W in dB/oct: Octave sound power level of air generated noise
L_W = L_{WA} + ΔL

Effective outlet area A_{eff}

Size	250	300	400	450	500	600/625
A _{eff}	0.00917	0.0137	0.0259	0.0336	0.0424	0.0635

Acoustic Data ADD - ... - ZV

Supply Air

Correction to Diagram 1: Control damper setting

Damper angle α	0°	45°	90°
Δp_t	x 1.0	x 1.2	x 2.8
L_{WA}/L_{WNC}	+ 0	+ 2.0	+ 4.0

Correction to Diagram 3: Control damper setting

Damper angle α	0°	45°	90°
Δp_t	x 1.0	x 1.8	x 4.3
L_{WA}/L_{WNC}	+ 0	+ 5.0	+ 12.0

Correction to Diagram 2: Control damper setting

Damper angle α	0°	45°	90°
Δp_t	x 1.0	x 1.6	x 4.0
L_{WA}/L_{WNC}	+ 0	+ 4.0	+ 5.0

Correction to Diagram 4: Control damper setting

Damper angle α	0°	45°	90°
Δp_t	x 1.0	x 1.7	x 3.9
L_{WA}/L_{WNC}	+ 0	+ 3.0	+ 7.0

**1 Sound power level and pressure drop
Size 250**

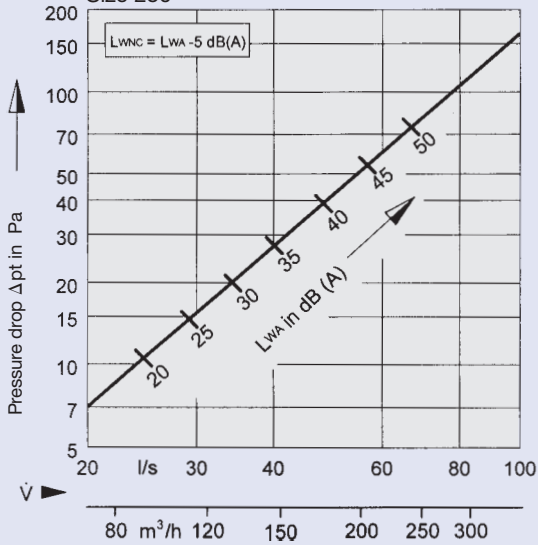

**3 Sound power level and pressure drop
Size 400**

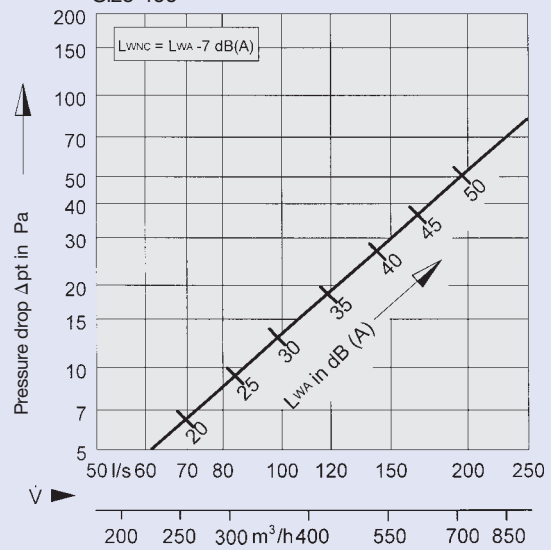

**2 Sound power level and pressure drop
Size 300**

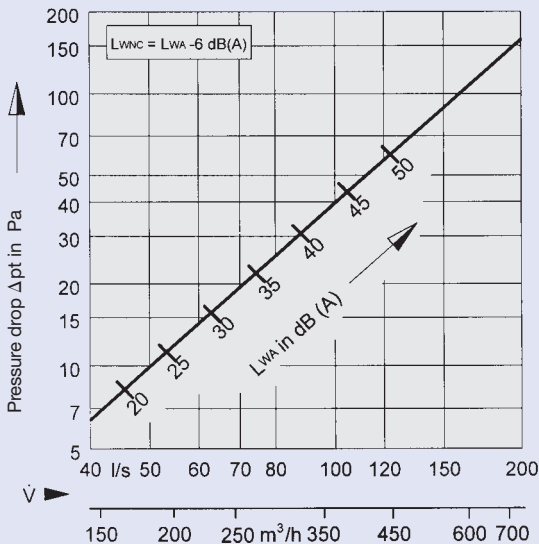

**4 Sound power level and pressure drop
Size 450**

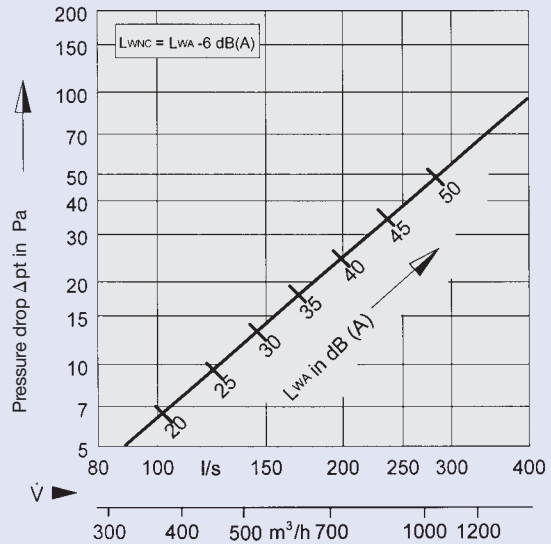

5 Sound power level and pressure drop
Size 500

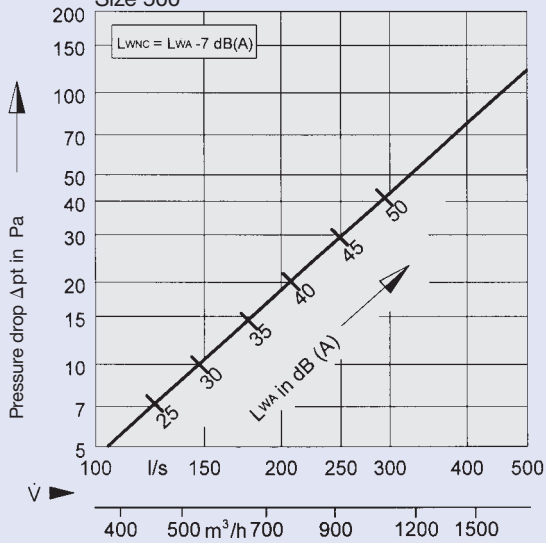

Correction to Diagram 5: Control damper setting

Damper angle α	0°	45°	90°
Δp_t	x 1.0	x 1.8	x 4.7
L_{WA}/L_{WNC}	+ 0	+ 5.0	+ 9.0

6 Sound power level and pressure drop
Size 600/625

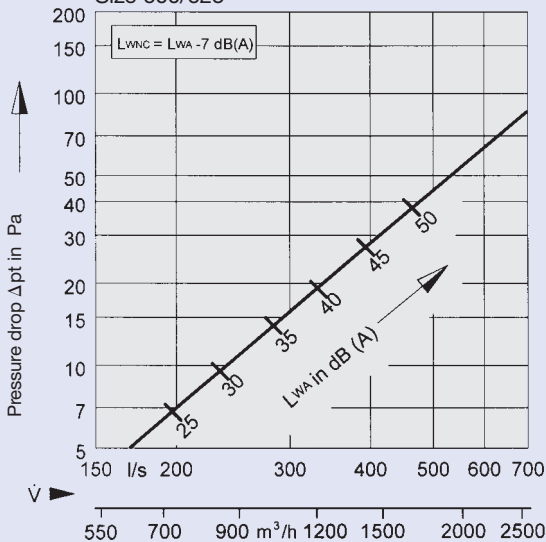

Correction to Diagram 6: Control damper setting

Damper angle α	0°	45°	90°
Δp_t	x 1.0	x 1.7	x 6.6
L_{WA}/L_{WNC}	+ 0	+ 4.0	+ 8.0

Acoustic Data ADD - ... - ZH

Supply Air

Correction to Diagram 7: Control damper setting

Damper angle α	0°	45°	90°
Δp_t	x 1	x 1.2	x 2.4
L_{WA}/L_{WNC}	+ 0	+ 0	+ 2.0

Correction to Diagram 9: Control damper setting

Damper angle α	0°	45°	90°
Δp_t	x 1	x 1.3	x 2.8
L_{WA}/L_{WNC}	+ 0	+ 2.0	+ 5.0

Correction to Diagram 8: Control damper setting

Damper angle α	0°	45°	90°
Δp_t	x 1	x 1.3	x 2.6
L_{WA}/L_{WNC}	+ 0	+ 2.0	+ 4.0

Correction to Diagram 10: Control damper setting

Damper angle α	0°	45°	90°
Δp_t	x 1	x 1.2	x 2.6
L_{WA}/L_{WNC}	+ 0	+ 0	+ 2.0

7 Sound power level and pressure drop
Size 250

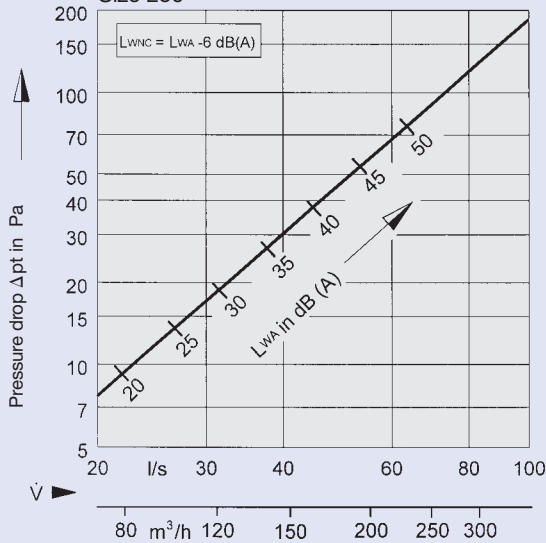

9 Sound power level and pressure drop
Size 400

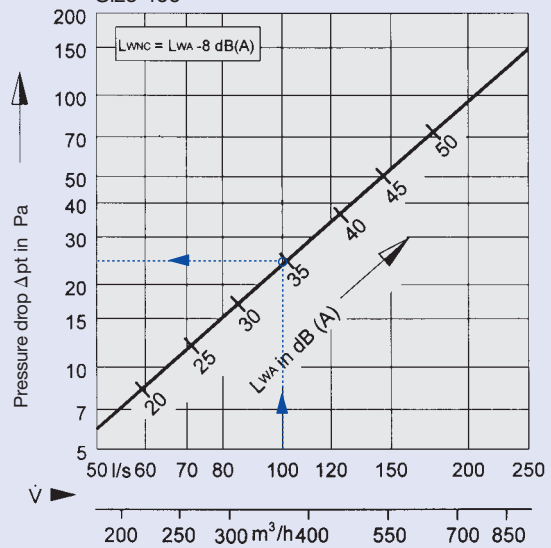

8 Sound power level and pressure drop
Size 300

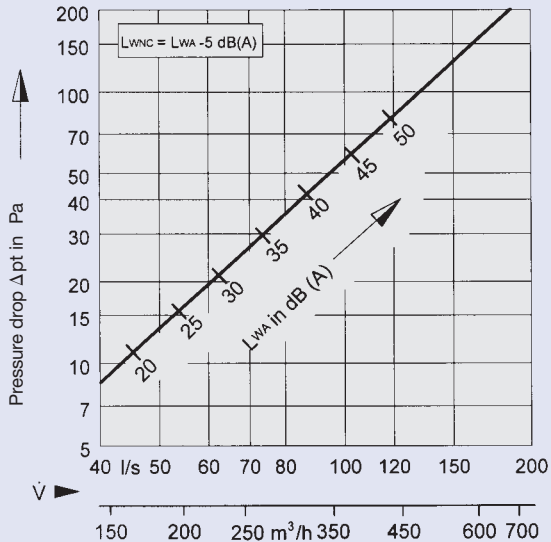

10 Sound power level and pressure drop
Size 450

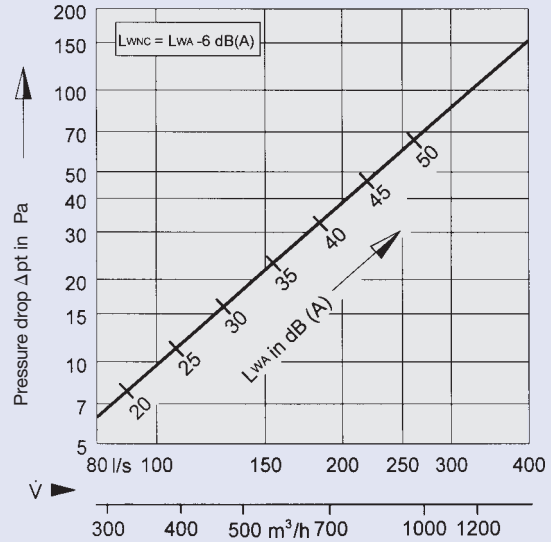

Acoustic Data ADD - ... - ZH

Supply air

Example:

Data given:

2 units Type ADD-Q-ZH/400

Volume flow per diffuser

$$\dot{V} = 100 \text{ l/s}$$

Supply air temperature differential

$$\Delta t_z = -8 \text{ K}$$

Spacing between two diffusers

$$A = 2.00 \text{ m}$$

Distance from diffuser centre line to wall

$$X = 1.50 \text{ m}$$

Distance between ceiling and occupied zone

$$H_1 = 1.20 \text{ m}$$

Diagram 29:

$$L = A/2 + H_1 = 1.00 + 1.20 = 2.20 \text{ m}$$

$$\Delta t_L / \Delta t_z = 0.16$$

$$\Delta t_L = -8 \cdot 0.16 = -1.6 \text{ K between two diffusers}$$

$$L = X + H_1 = 1.50 + 1.20 = 2.70 \text{ m}$$

$$\Delta t_L / \Delta t_z = -0.11$$

$$\Delta t_L = -8 \cdot 0.11 = -0.88 \text{ K at the wall}$$

$$\bar{v}_L \sim 0.25 \text{ m/s}$$

Temperature quotient

Diagram 9:

Sound power and pressure drop

$$L_{WA} = 35 \text{ dB(A)} \quad (L_{WNC} = 27 \text{ NC})$$

$$\Delta p_t = 25 \text{ Pa}$$

Diagram 30:

Single row or more than one row of diffusers

$$\bar{v}_{H1} = 0.20 \text{ m/s}$$

11 Sound power level and pressure drop
Size 500

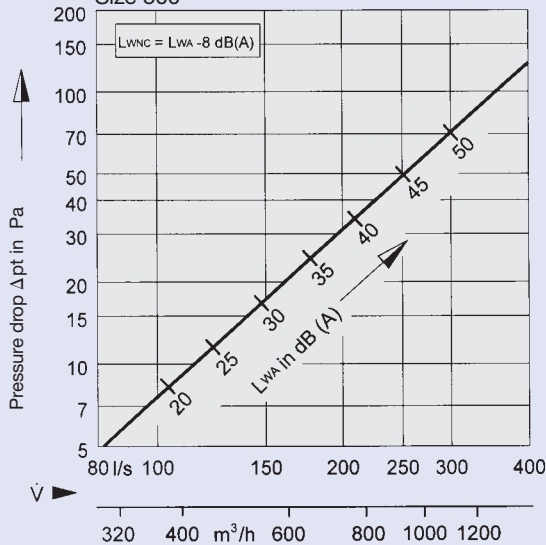

Correction to Diagram 11: Control damper setting

Damper angle α	0°	45°	90°
Δp_t	x 1	x 1.3	x 2.9
L_{WA}/L_{WNC}	+ 0	+ 2.0	+ 6.0

12 Sound power level and pressure drop
Size 600/625

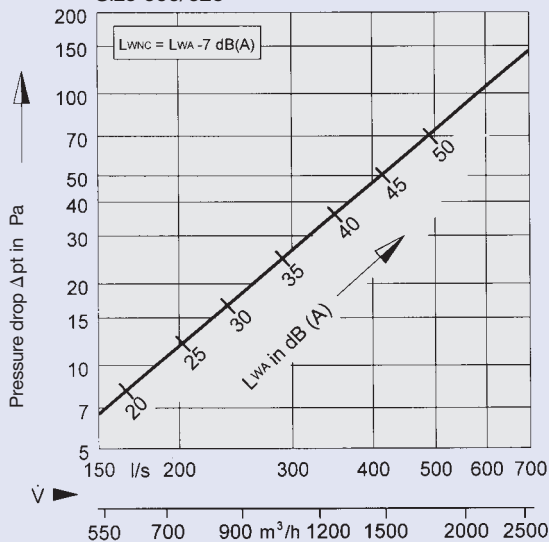

Correction to Diagram 12: Control damper setting

Damper angle α	0°	45°	90°
Δp_t	x 1	x 1.4	x 2.5
L_{WA}/L_{WNC}	+ 0	+ 2.0	+ 5.0

Acoustic Data ADD - ... - AV

Extract air

Correction to Diagram 13: Control damper setting

Damper angle α	0°	45°	90°
Δp_t	x 1.0	x 1.4	x 2.4
L_{WA}/L_{WNC}	+ 0	+ 2.0	+ 6.0

Correction to Diagram 15: Control damper setting

Damper angle α	0°	45°	90°
Δp_t	x 1.0	x 1.3	x 2.5
L_{WA}/L_{WNC}	+ 0	+ 1.0	+ 7.0

Correction to Diagram 14: Control damper setting

Damper angle α	0°	45°	90°
Δp_t	x 1.0	x 1.4	x 3.2
L_{WA}/L_{WNC}	+ 0	+ 3.0	+ 10.0

Correction to Diagram 16: Control damper setting

Damper angle α	0°	45°	90°
Δp_t	x 1.0	x 1.5	x 2.8
L_{WA}/L_{WNC}	+ 0	+ 2.0	+ 9.0

13 Sound power level and pressure drop
Size 250

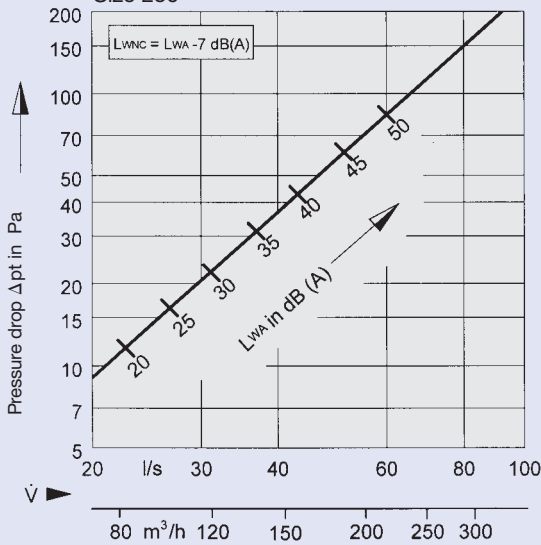

15 Sound power level and pressure drop
Size 400

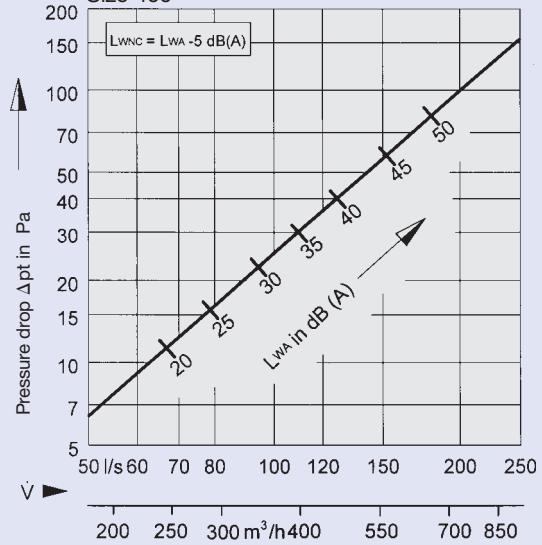

14 Sound power level and pressure drop
Size 300

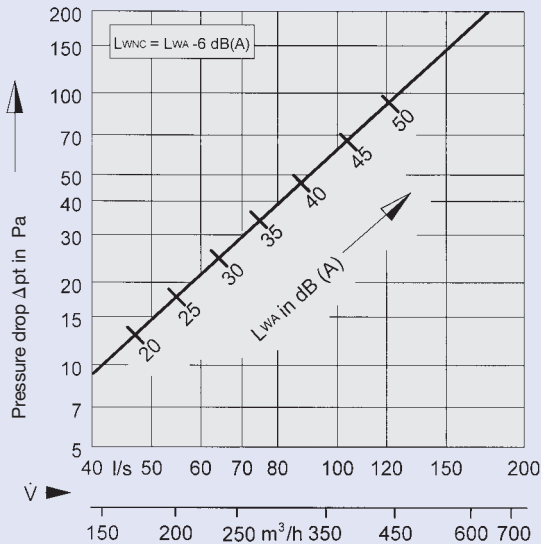

16 Sound power level and pressure drop
Size 450

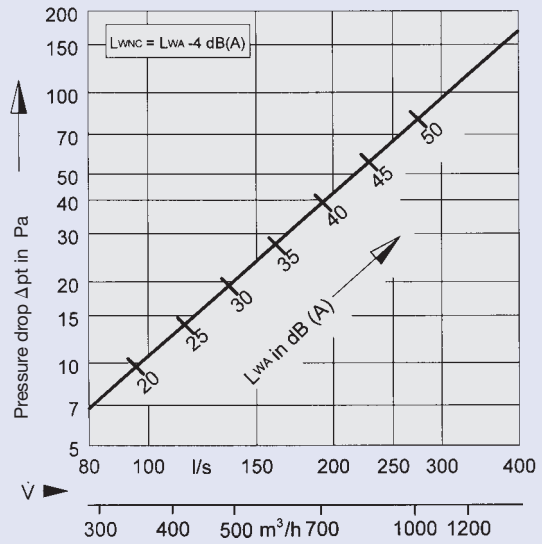

17 Sound power level and pressure drop
Size 500

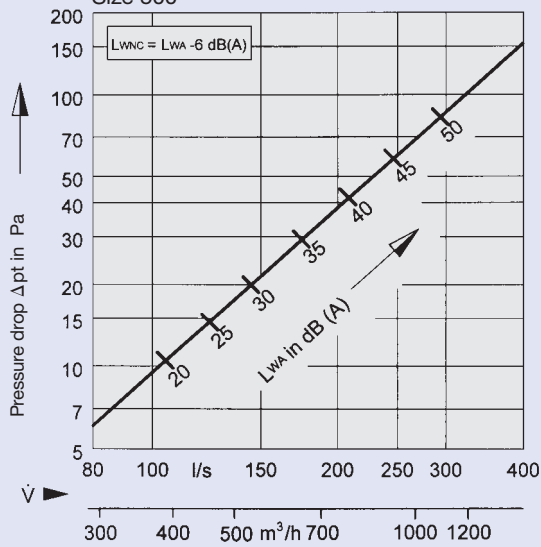

Correction to Diagram 17: Control damper setting

Damper angle α	0°	45°	90°
Δp_t	x 1.0	x 1.5	x 2.9
L_{WA}/L_{WNC}	+ 0	+ 2.0	+ 9.0

18 Sound power level and pressure drop
Size 600/625

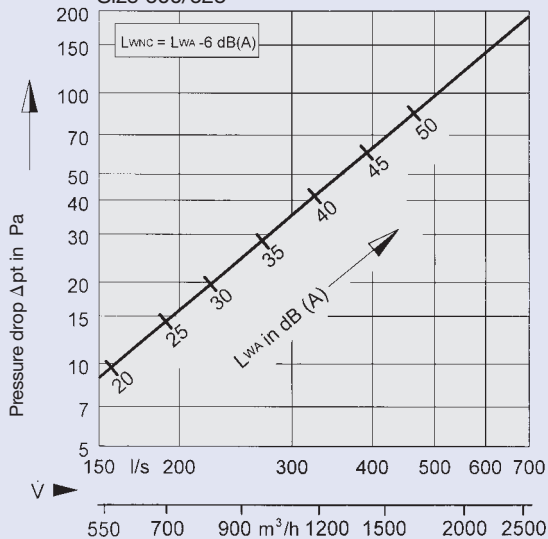

Correction to Diagram 18: Control damper setting

Damper angle α	0°	45°	90°
Δp_t	x 1.0	x 1.3	x 2.8
L_{WA}/L_{WNC}	+ 0	+ 2.0	+ 9.0

Acoustic Data ADD - ... - AH

Extract air

Correction to Diagram 19: Control damper setting

Damper angle α	0°	45°	90°
Δp_t	x 1.0	x 1.1	x 1.6
L_{WA}/L_{WNC}	+ 0	+ 0	+ 1.5

Correction to Diagram 21: Control damper setting

Damper angle α	0°	45°	90°
Δp_t	x 1.0	x 1.2	x 2.3
L_{WA}/L_{WNC}	+ 0	+ 2.0	+ 6.0

Correction to Diagram 20: Control damper setting

Damper angle α	0°	45°	90°
Δp_t	x 1.0	x 1.2	x 2.0
L_{WA}/L_{WNC}	+ 0	+ 2.0	+ 4.0

Correction to Diagram 22: Control damper setting

Damper angle α	0°	45°	90°
Δp_t	x 1.0	x 1.3	x 2.2
L_{WA}/L_{WNC}	+ 0	+ 2.0	+ 5.0

19 Sound power level and pressure drop
Size 250

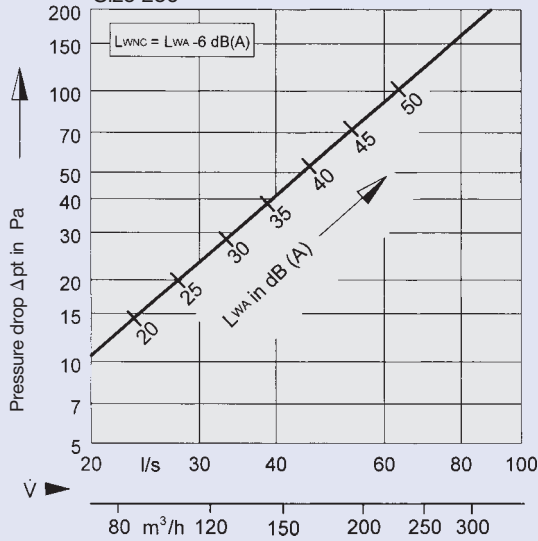

21 Sound power level and pressure drop
Size 400

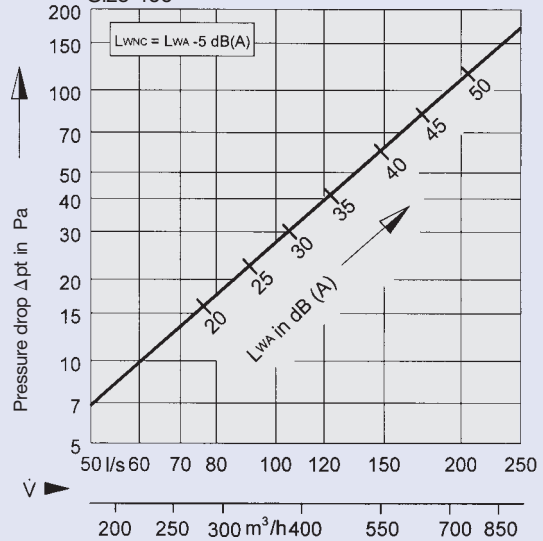

20 Sound power level and pressure drop
Size 300

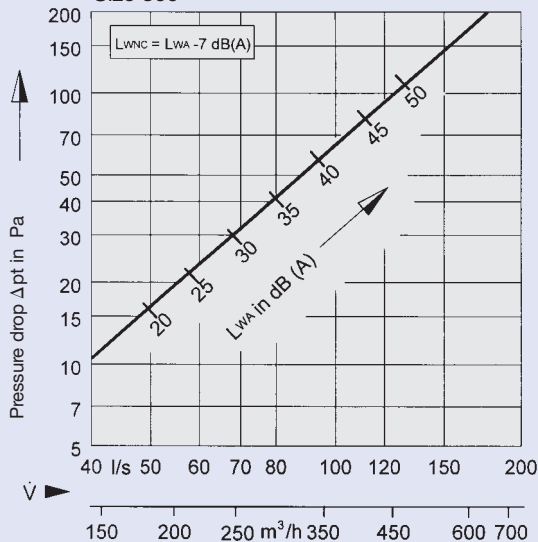

22 Sound power level and pressure drop
Size 450

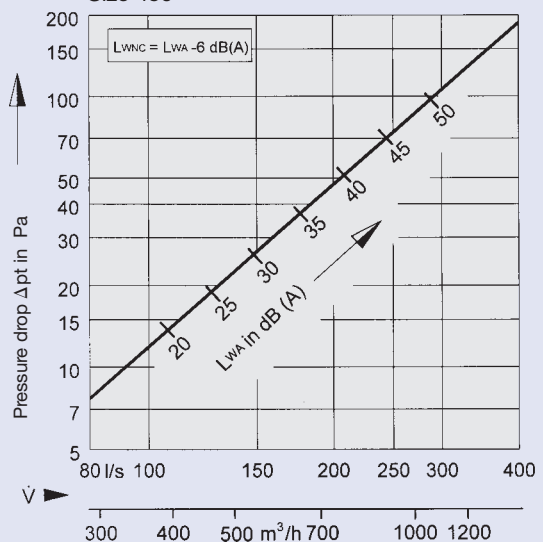

23 Sound power level and pressure drop
Size 500

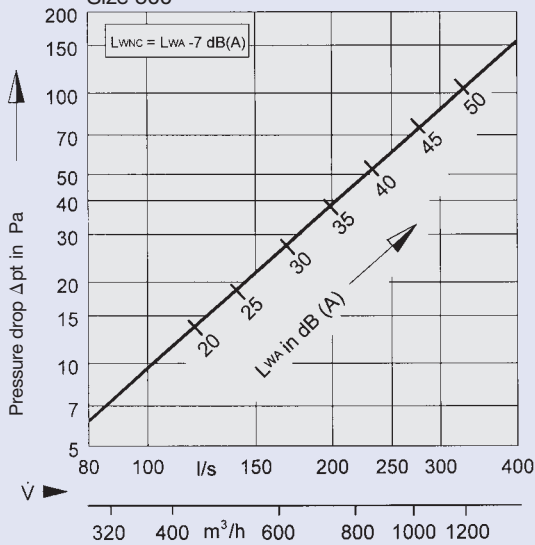

Correction to Diagram 23: Control damper setting

Damper angle α	0°	45°	90°
Δp_t	x 1.0	x 1.3	x 2.1
L_{WA}/L_{WNC}	+ 0	+ 2.0	+ 5.0

24 Sound power level and pressure drop
Size 600/625

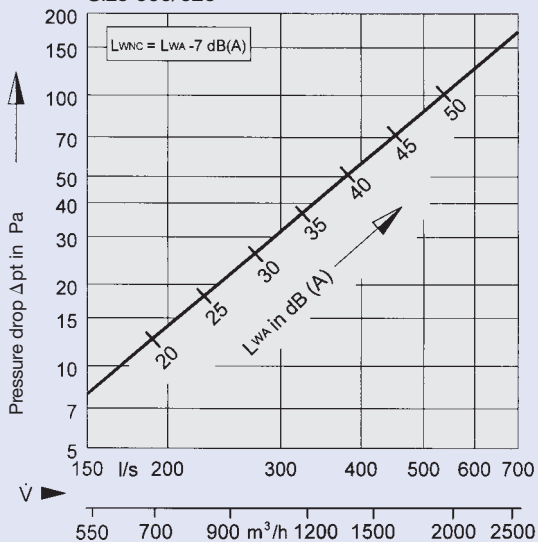

Correction to Diagram 24: Control damper setting

Damper angle α	0°	45°	90°
Δp_t	x 1.0	x 1.3	x 2.6
L_{WA}/L_{WNC}	+ 0	+ 5.0	+ 12.0

Aerodynamic Data

Sizes 250 and 300

Correction:

Where installed below the ceiling the values

\bar{v}_{H1} , \bar{v}_L and $\Delta t_L / \Delta t_z$ must be multiplied by 0.71!

25 Temperature quotient: Size 250

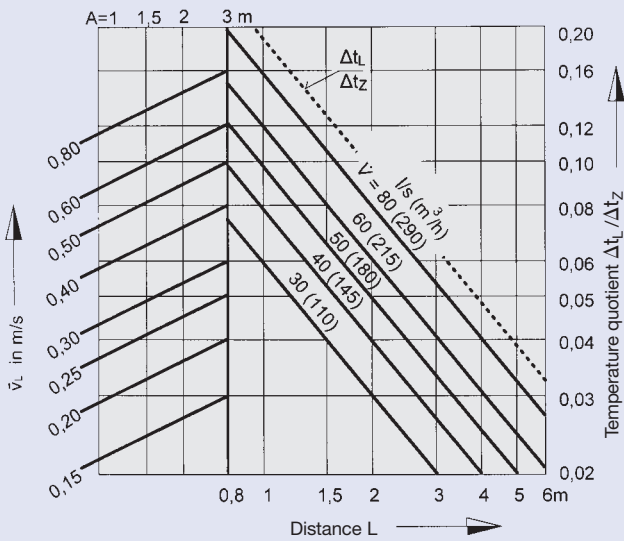

27 Temperature quotient: Size 300

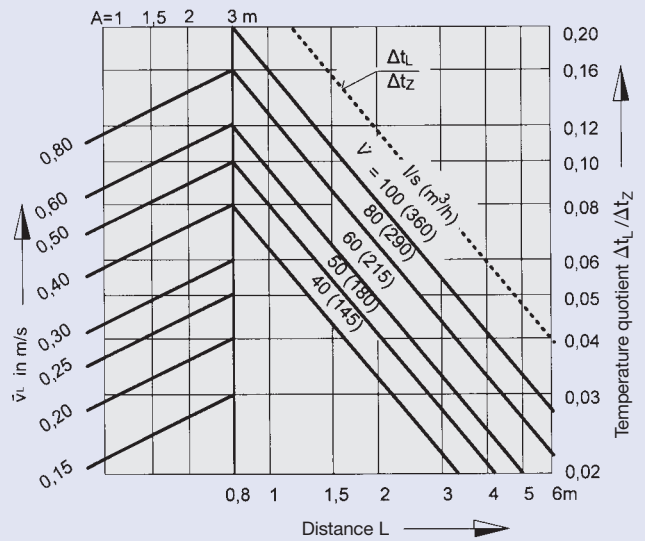

26 Diffuser arrangement: Size 250

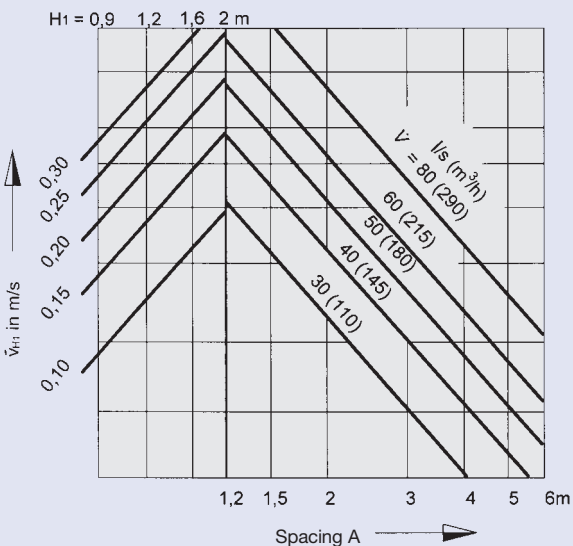

28 Diffuser arrangement: Size 300

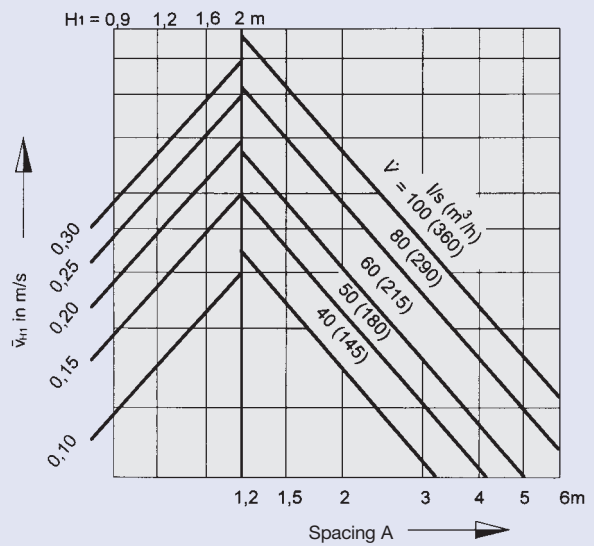

Aerodynamic Data

Sizes 400 and 450

Correction:

Where installed below the ceiling the values

\bar{v}_{H1} , \bar{v}_L and $\Delta t_L / \Delta t_z$ must be multiplied by 0.71!

29 Temperature quotient: Size 400

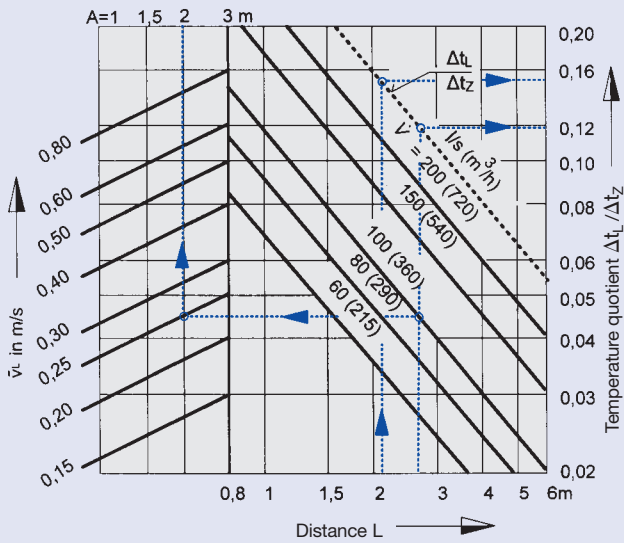

31 Temperature quotient: Size 450

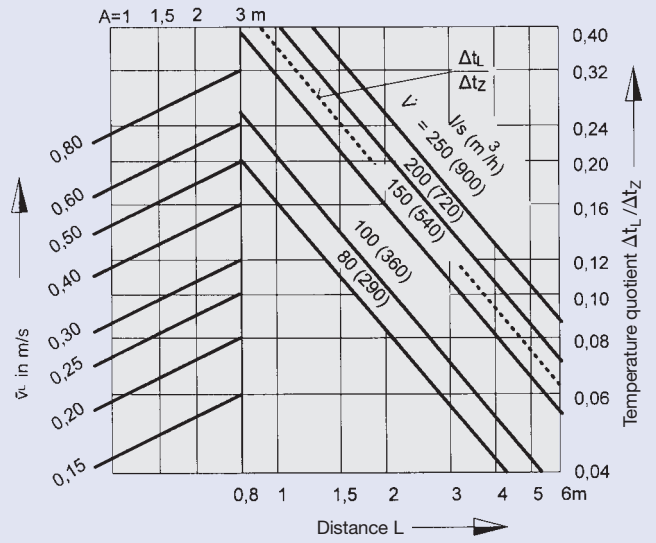

30 Diffuser arrangement: Size 400

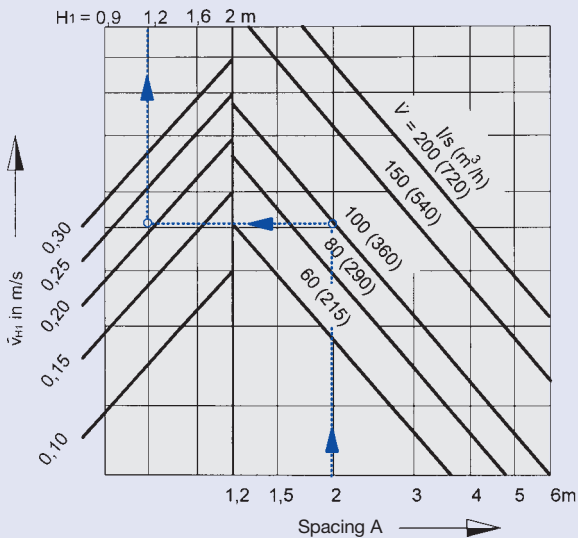

32 Diffuser arrangement: Size 450

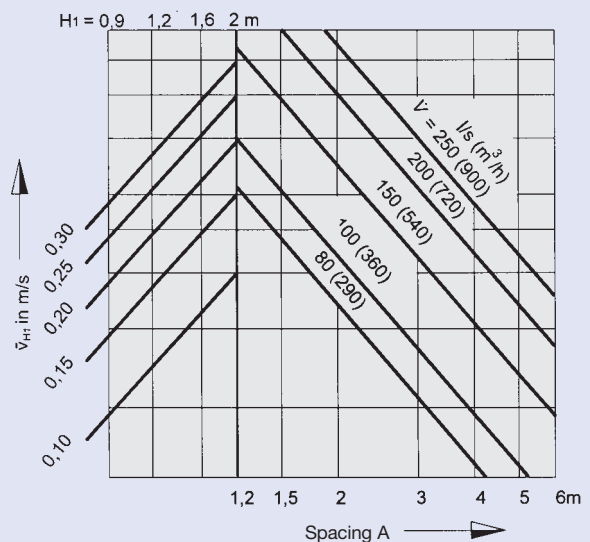

Aerodynamic Data

Sizes 500 and 600/625

Correction:

Where installed below the ceiling the values

\bar{v}_{H1} , \bar{v}_L and $\Delta t_L / \Delta t_z$ must be multiplied by 0.71!

33 Temperature quotient: Size 500

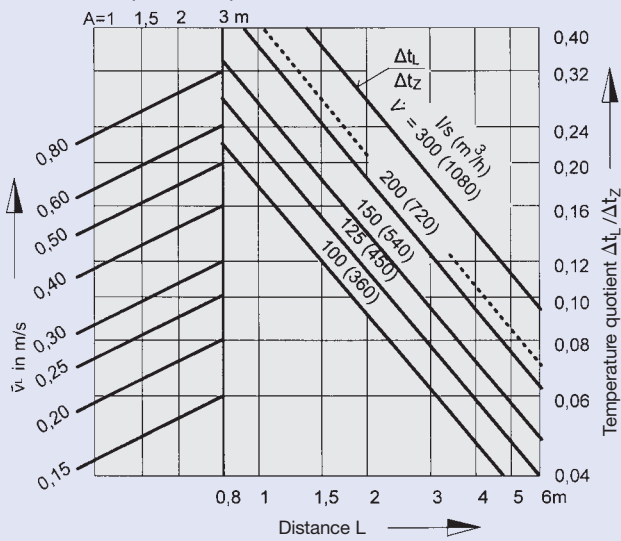

35 Temperature quotient: Size 600/625

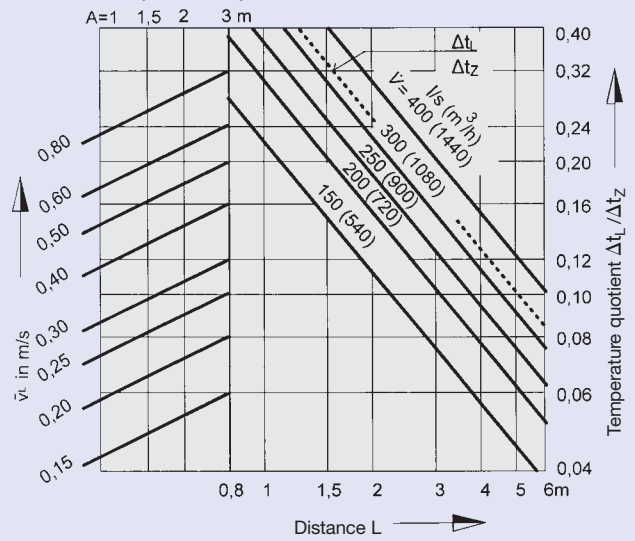

34 Diffuser arrangement: Size 500

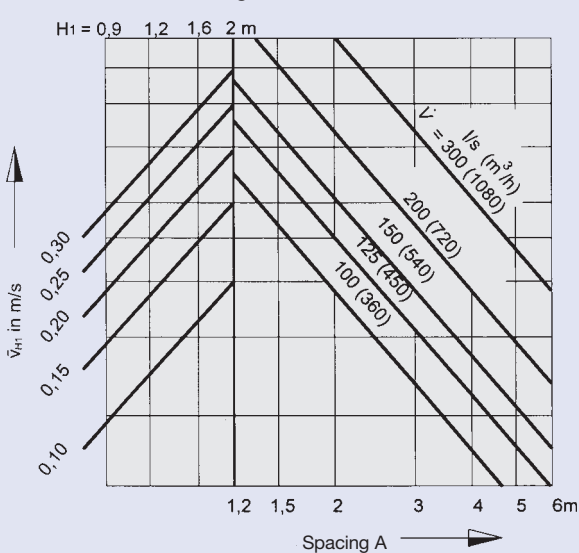

36 Diffuser arrangement: Size 600/625

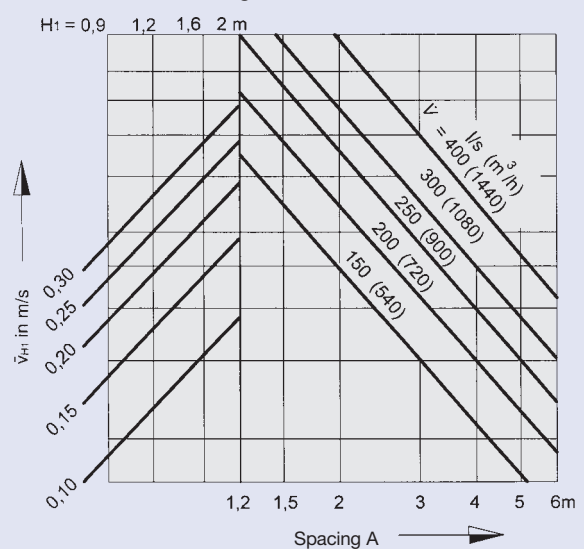

Specification text

Designer diffusers Type ADD for supply and extract air, comprising diffuser face with circular or square faceplate, rear air control ring and swirl unit, extract air version without swirl unit.

Plenum box with circular top or side entry spigot, optionally with volume control damper and/or lip seal, or with reference pressure measurement and cable operated damper. The entire assembly is suspended using holes in the top return edge of the plenum or hanging brackets provided.

The diffuser face can be fitted or removed from the plenum box by means of a centre fixing bolt which locates in a plenum bridge.

Materials:

Galvanized sheet steel faceplate powder-coated white (RAL 9010, gloss level 50%), aluminium control ring, stove enamelled black (RAL 9005), galvanized sheet steel swirl unit, stove-enamelled black (RAL 9005), sheet steel plenum box, rubber lip seal.

Order code

These codes do not need to be completed for standard products

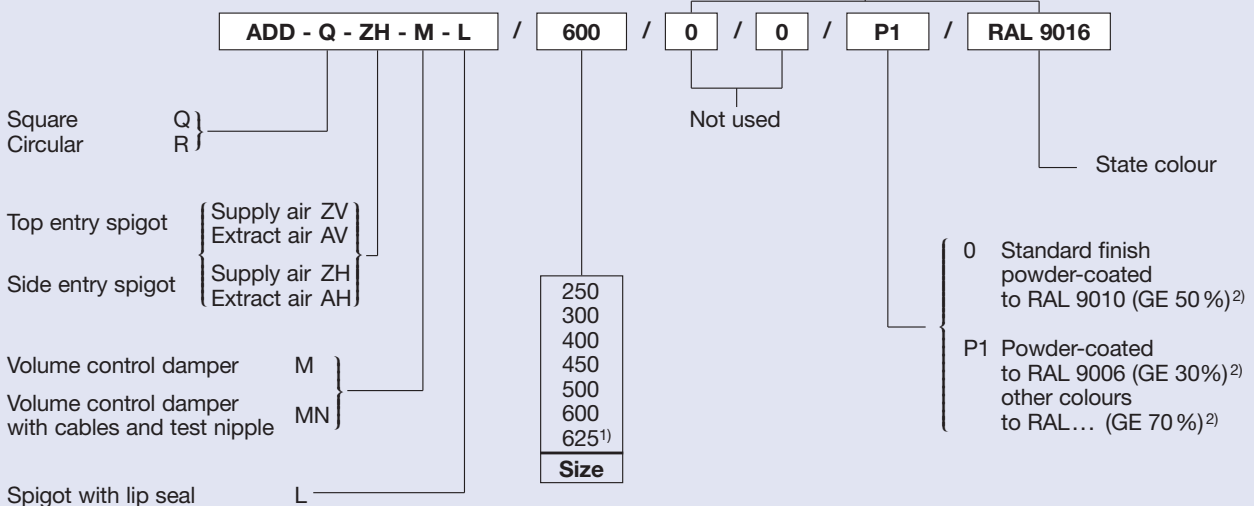

1) Not for ADD-R!
2) GE = Gloss level!

Order Example:

Make: TROX
Type: ADD - Q - ZH - M - L / 600 / P1 / RAL 9016