

# Active Chilled Beams

- Type DID-E
- Air discharge one way

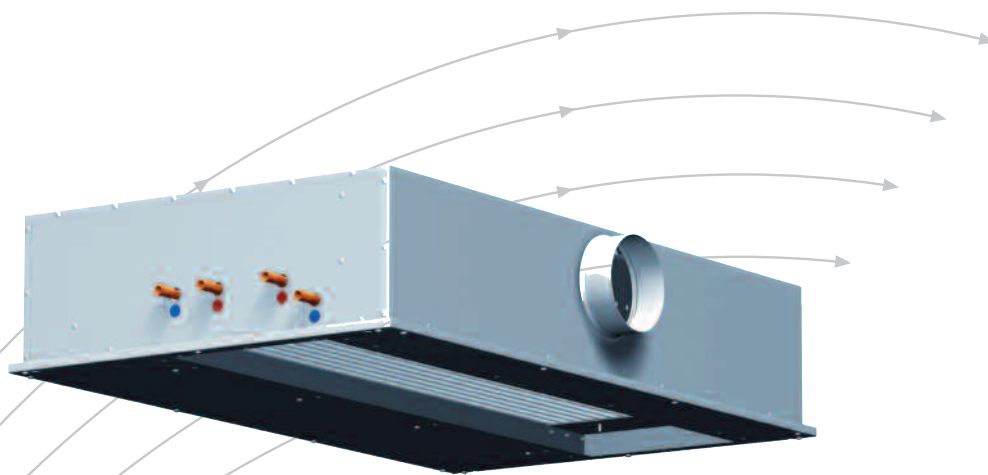

**TROX<sup>®</sup> TECHNIK**

The art of handling air



# Contents · Description

|                           |    |
|---------------------------|----|
| Description               | 2  |
| Functional description    | 3  |
| Construction · Dimensions | 4  |
| Installation              | 5  |
| Assembly                  | 6  |
| Nomenclature              | 7  |
| Selection example         | 8  |
| Quick selection           | 9  |
| Water-side capacity       | 10 |
| Aerodynamic data          | 11 |
| Order Details             | 12 |



Active chilled beams Type DID-E with one way air discharge using air-water systems provide a comfortable air conditioning of rooms with a high cooling load.

They combine the aerodynamic properties of sidewall grilles with the energy benefits of load dissipation using water.

They are particularly suited for hotel bedrooms, individual hospital wards as well as cellular offices.

### Special characteristics

- High cooling capacity with low conditioned fresh air flow rates
- Many options of grille design, e.g. TROX AH, VAT or HESCO DG1
- Heat exchangers for two or four pipe systems
- Heating and/or cooling is possible

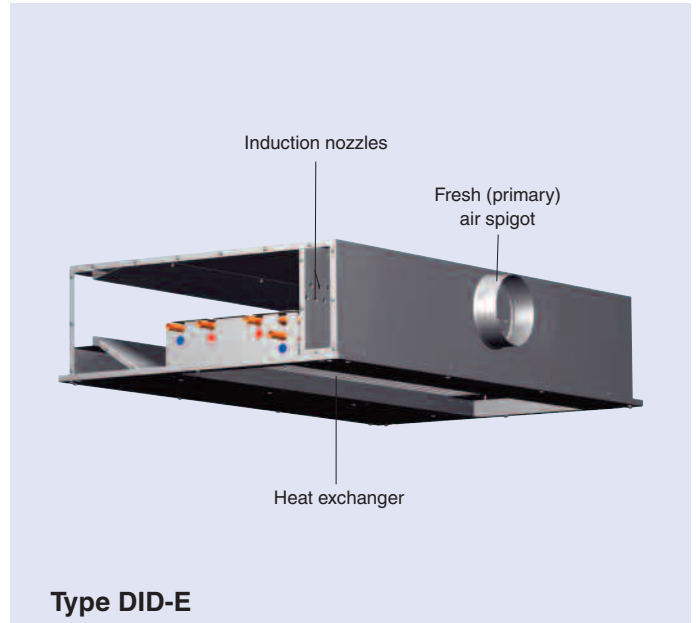

**Type DID-E**

The active chilled beams contain an internal plate with punched nozzles, a horizontal heat exchanger, and a spigot for the connection of the conditioned fresh air.

Further, current information on design can be found on our Website and in our "Air-water systems" design manual.

Our "Easy Product Finder" online design programme is also available on the Internet for the design and selection of our products.

### Certification of EUROVENT

TROX is participating in the Eurovent Certification Programme for Chilled Beams. Products are certified under the number 09.12.432 and presented on the Eurovent Website.

# Functional description

- Active chilled beams supply conditioned fresh air (primary air) to the space from a central plant room to maintain indoor air quality whilst providing additional cooling and/or heating using heat exchangers.

The primary air is discharged into the beam mixing chamber via nozzles. As a result of this secondary air is induced via an inlet grille and then passes through a horizontally mounted heat exchanger into the mixing chamber. Both air flows mix and the total supply air is discharged horizontally into the space through a supply grille.

There are three nominal lengths each having the option of two heat exchanger widths and three different nozzle arrays (one in two rows). This allows the optimum selection to meet fresh air flow rate and thermal capacity requirements whilst exhibiting low differential pressures and sound power level characteristics.

There are two types of heat exchanger, one is a two pipe system for cooling, heating can be provided using a changeover mode. The other is a four pipe system which enables any room to be cooled or heated independently of other rooms. Operation below the dew point (wet operation) must be avoided.

## Principle of operation

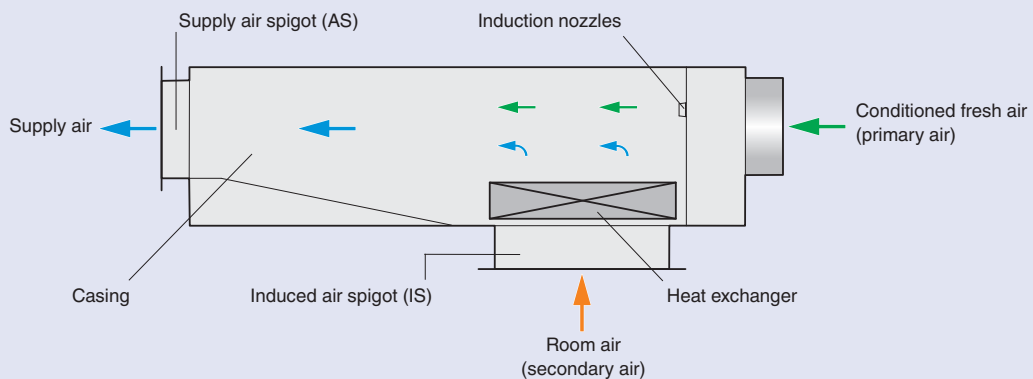

### Four pipe system Heating and cooling

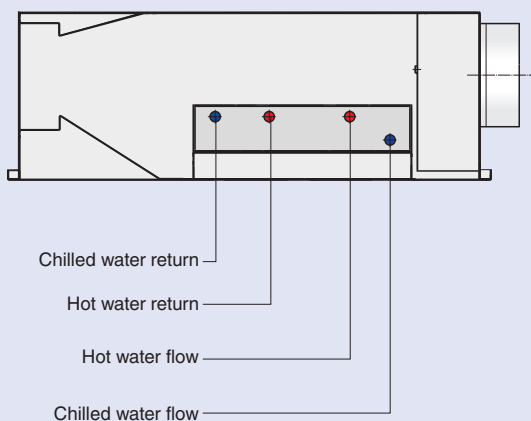

### Two pipe system Heating or cooling

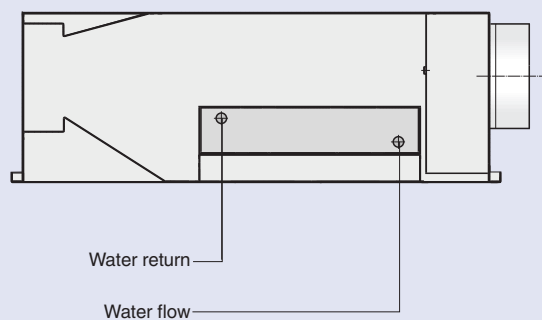

# Construction · Dimensions

## Characteristics

- Fresh air range 10 to 80 l/s, 36 to 288 m<sup>3</sup>/h
  - For clear room heights from approximately 2.6 to 4.0 m
  - Installation into a formed plaster board bulkhead, e.g. of hotel bedrooms
  - Many options of induced and supply air grille design (please order separately)
  - Two heat exchanger widths available
  - Heat exchangers for two or four pipe systems
  - Nozzles in three alternatives to optimise induction
  - Nozzles punched in sheet metal plate, non-combustible
  - Induced and supply air spigot can be supplied as accessories
  - Maximum operating pressure: 6 bar
  - Maximum operating temperature: 75 °C
- Other operating pressures and temperatures upon request.

## Construction features

- Spigot connections suitable for circular connecting ducts according to EN 1506 or EN 13180
- 4 suspension holes for on-site installation
- Water connections, Ø12 mm plain end or with external thread G½", flat end seal

## Materials

- Casing and nozzle plate made of galvanised sheet steel.
- Heat exchanger made of copper tubes and formed aluminium fins
- Casing and heat exchanger option, finish black (RAL 9005)

### DID-E...-LI

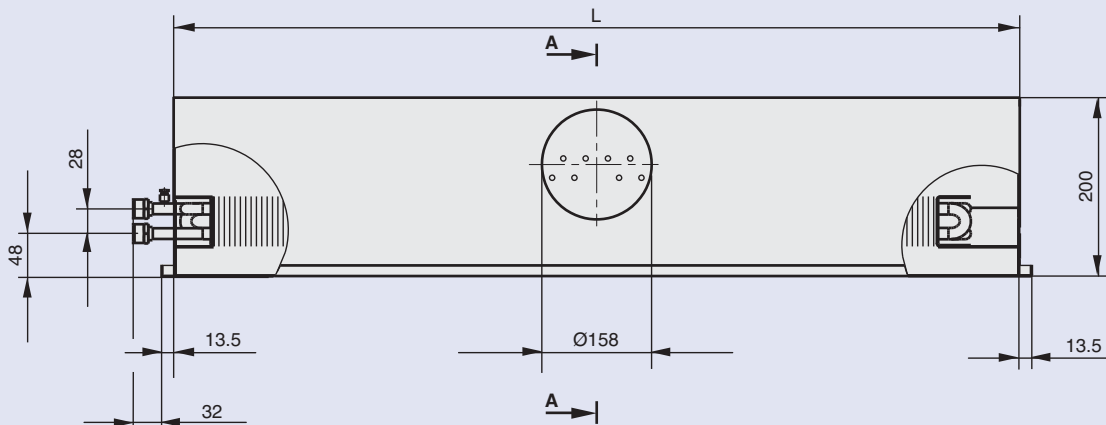

### View A - A

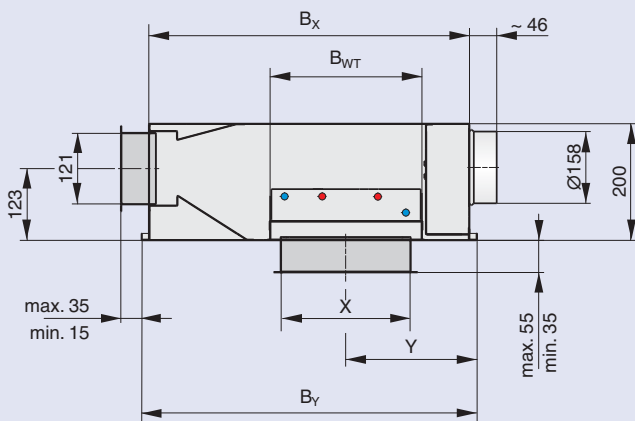

### Dimensions in mm

| L <sub>N</sub> | B <sub>WT</sub> | L    | B <sub>X</sub> | B <sub>Y</sub> | E   | X   | Y   |
|----------------|-----------------|------|----------------|----------------|-----|-----|-----|
| 900            | 256             | 948  | 550            | 576            | 160 | 221 | 225 |
|                | 320             |      | 614            | 640            | 318 | 224 | 257 |
| 1200           | 256             | 1248 | 550            | 576            | 160 | 221 | 225 |
|                | 320             |      | 614            | 640            | 318 | 224 | 257 |
| 1500           | 256             | 1548 | 550            | 576            | 160 | 221 | 225 |
|                | 320             |      | 614            | 640            | 318 | 224 | 257 |

L<sub>N</sub> = nominal length  
 B<sub>WT</sub> = heat exchanger width  
 L = casing length  
 overall length = L + 27

- The customer must install the active chilled beams, make all connections, and provide the hanging system, connection and sealing materials.

Only trained expert personnel should install and make the appropriate connections.

All legal regulations for site work must be complied with.

The ideal installation is in formed plaster board bulkheads or in suspended ceilings of hotel bedrooms, individual hospital wards or cellular offices.

The active chilled beam has four suspension holes for suspending the unit from the ceiling slab using threaded rods, wires or metal hangers. Use only certified hanging systems.

The primary air is connected to the inlet spigot. The heat exchanger has common flow and return connections on the side of the unit (four connections in the case of a four pipe system). The actual connections can either be rigid – soldered or screw, or flexible – using push fit hoses. It is important to ensure adequate venting and draining facilities are provided.

Flexible hoses can be supplied as accessories see separate technical leaflet.

## DID-E...-LI

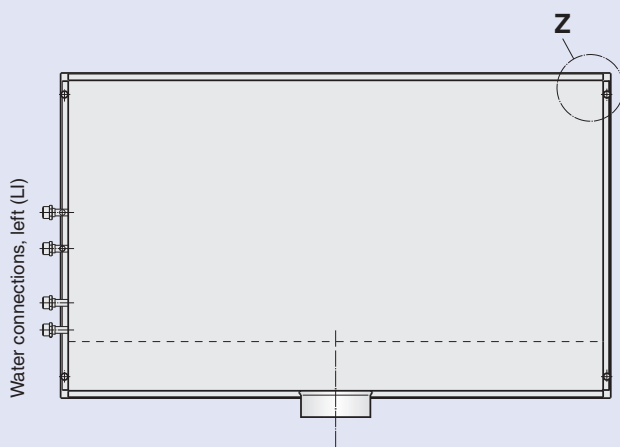
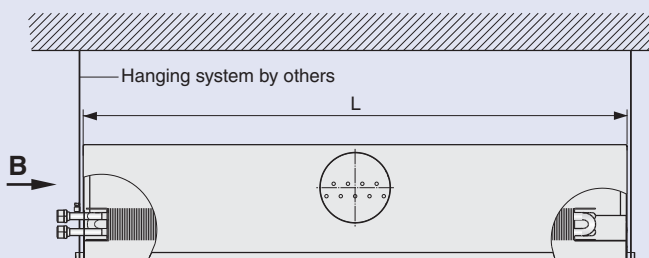

### Detail Z Suspension holes

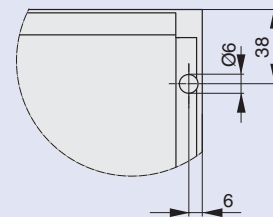

### View B Left hand connections (LI)

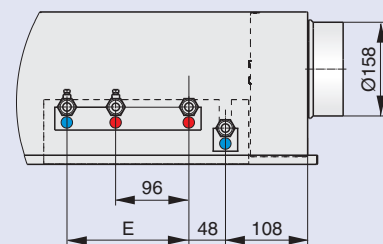

### View B Right hand connections (RE)

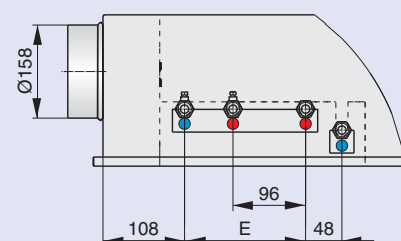

# Assembly

## Induced and supply air grille

The plaster board bulkhead must have two openings for the induced and supply air. Installation is easier with induced and supply air spigots which can be supplied as accessories

For optimum air supply into the space TROX grilles should be used for supply and induced air.

If supplied by others the on-site induction aperture cover must have at least 50 % free area e.g. perforated plate.

## Maintenance

As is the case with all grilles that induce room air, depending on the cleanliness of the room air, deposits may accumulate on the surfaces of the grille. If required, clean the grille with commercial, non-aggressive cleaning agents.

Clean the heat exchanger with an industrial vacuum cleaner. For maintenance, also see VDI 6022, Sheet 1 – “Hygiene Requirements on Ventilation Systems”.

## Removal of the induced air grille

In case that TROX induced air spigot and recommended grille have been used, the heat exchanger is accessible when the induced air grille has been removed.

To remove the induced air grille release the concealed screw fixings.

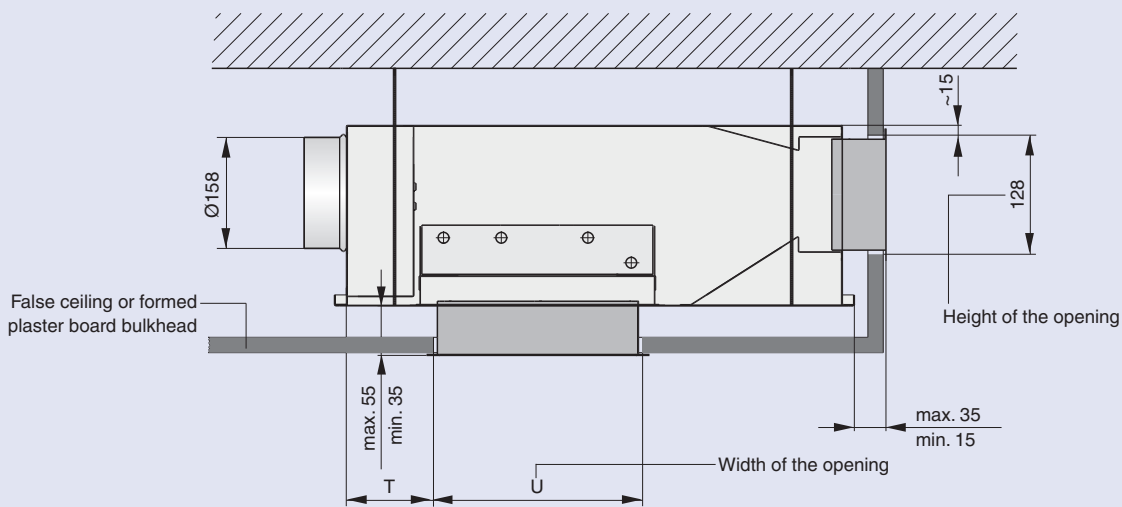

Dimensions in mm

| L <sub>N</sub> | Length                        | Length               | Height            | B <sub>WT</sub> | Height             | T   | U   | Grille dimensions  |                   |
|----------------|-------------------------------|----------------------|-------------------|-----------------|--------------------|-----|-----|--------------------|-------------------|
|                | Induced and supply air grille | Installation opening | Supply air grille |                 | Induced air grille |     |     | Induced air spigot | Supply air spigot |
| 900            | 925                           | 928                  | 125               | 256             | 225                | 101 | 228 | 925 × 225          | 925 × 125         |
|                |                               |                      |                   | 320             | 325                | 85  | 328 | 925 × 325          |                   |
| 1200           | 1225                          | 1228                 | 125               | 256             | 225                | 101 | 228 | 1225 × 225         | 1225 × 125        |
|                |                               |                      |                   | 320             | 325                | 85  | 328 | 1225 × 325         |                   |
| 1500           | 1525                          | 1528                 | 125               | 256             | 225                | 101 | 228 | 1525 × 225         | 1525 × 125        |
|                |                               |                      |                   | 320             | 325                | 85  | 328 | 1525 × 325         |                   |

# Nomenclature

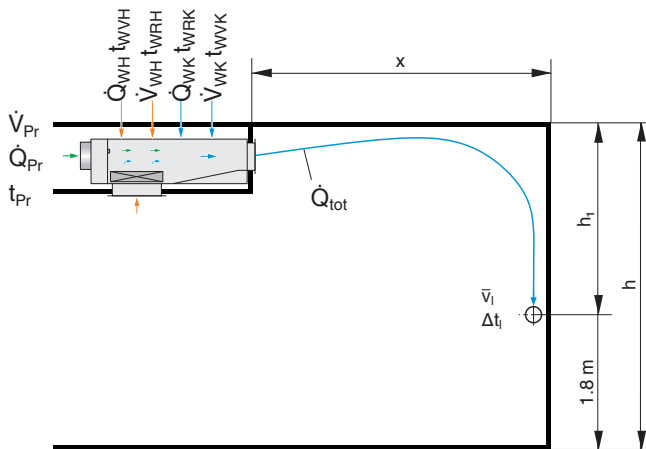

|                  |  |
|------------------|--|
| $\Delta t_i$     | in K : Temperature difference between room air and core at distance $l = x + h_1$                                      |
| $\Delta t_{Pr}$  | in K : Temperature difference between room air and conditioned fresh air   |
| $\Delta t_W$     | in K : Temperature difference between water flow and return  |
| $\Delta t_{RWW}$ | in K : Temperature difference between room air and water flow  |
| $\Delta p_t$     | in Pa : Total differential pressure  |
| $\Delta p_W$     | in kPa : Water-side pressure differential  |
| $t_R$            | in °C : Room temperature   |
| $t_{WVK}$        | in °C : Water flow temperature – cooling   |
| $t_{WRK}$        | in °C : Water return temperature – cooling   |
| $t_{WVH}$        | in °C : Water flow temperature – heating   |
| $t_{WRH}$        | in °C : Water return temperature – heating   |
| $t_{Pr}$         | in °C : Temperature of the conditioned fresh air   |
| $Q_{WK}$         | in W : Water cooling capacity  |
| $Q_{WH}$         | in W : Water heating capacity  |
| $Q_{tot}$        | in W : Total cooling capacity $Q_{Pr} + Q_{WK}$  |
| $Q_{Pr}$         | in W : Conditioned fresh air cooling capacity  |
| $V_{WK}$         | in l/h : Water flow rate – cooling   |
| $V_{WH}$         | in l/h : Water flow rate – heating   |
| $V_{Pr}$         | in l/s, m <sup>3</sup> /h : Conditioned fresh air flow rate  |
| $\bar{v}_i$      | in m/s : Maximum time average air velocity at wall at distance $l = x + h_1$   |
| $L_{WA}$         | in dB(A) : A-weighted sound power level  |
| $l$              | in m : Horizontal plus vertical distance from diffuser, discharge down the wall (1.8 m above the floor), $l = x + h_1$ |
| $h_1$            | in m : Distance from the ceiling to the occupied zone (1.8 m above the floor)  |
| $h$              | in m : Room height   |
| $x$              | in m : Distance between the grille and the wall  |

All sound power levels are based on 1 pW.

All noise levels determined in a reverberation chamber.

Technical data based on an air density of 1.2 kg/m<sup>3</sup>.

# Selection example

First step in selecting active chilled beams is based on the quick selection table (Page 9).

Listed capacities are valid only for the reference values.

Second step, if the operating values differ from the reference ones, corrections must be made using diagrams and tables pages 10 and 11.

Our "Easy Product Finder" online design programme is also available on the Internet for easy and detailed design of our products.

Following example shows the unit selection using this leaflet.

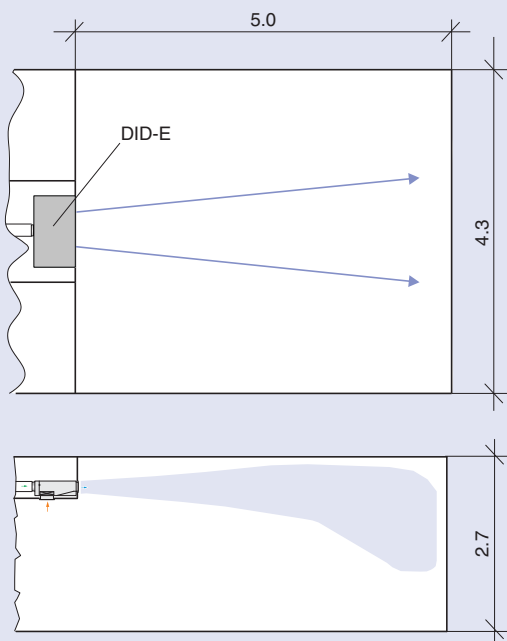

Dimensions in mm

## Given

|                                    |                     |
|------------------------------------|---------------------|
| Hotel bedroom                      |                     |
| Room width:                        | 4.3 m               |
| Room depth:                        | 5 m                 |
| Room height:                       | 2.7 m               |
| Occupancy:                         | 2 persons           |
| Cooling load:                      | 45 W/m <sup>2</sup> |
| Room temperature (Summer):         | 26 °C               |
| Conditioned fresh air temperature: | 16 °C               |
| Chilled water flow temperature:    | 16 °C               |

## Fresh air flow rates

According to EN 15251, low-pollution building, Category II,

|           |                          |
|-----------|--------------------------|
| Building: | 0.7 (l/s)/m <sup>2</sup> |
| People:   | 7.0 (l/s)/Person         |

## Calculation procedure

|  |          |
|--|----------|
| Fresh air flow rate:                           |          |
| 21.5 m <sup>2</sup> × 0.7 (l/s)/m <sup>2</sup> | = 15 l/s |
| 2 persons × 7 (l/s)/person                     | = 14 l/s |
| Total  | = 29 l/s |
| Cooling load:                                  |          |
| 21.5 m <sup>2</sup> × 45 W/m <sup>2</sup>      | = 968 W  |

## Data for quick selection, page 9

|                          |         |
|--------------------------|---------|
| DID-E                    |         |
| Nominal length:          | 1200 mm |
| Nozzle type:             | U       |
| Width of heat exchanger: | 256 mm  |

## Result of design

| Capacities and comfort parameters                                       | Source          | Formula   | Calculation       | Value            |
|---|-----------------|---|-------------------|------------------|
| Total cooling capacity each unit  | Quick selection |   |                   | 913 W            |
| Water cooling capacity at 110 l/h                                       | Quick selection |   |                   | 563 W            |
| Air cooling capacity  |                 | $\dot{Q}_{ges} - \dot{Q}_{WK}$                    | 913 - 563         | 350 W            |
| Cooling capacity too low, thus increase of water flow rate, try 180 l/h |                 |   |                   |                  |
| Correction factor for 180 l/h   | Page 9          |   |                   | 1.2              |
| Water cooling capacity at 180 l/h                                       |                 |   | 563 × 1.2         | 676 W            |
| Project total cooling capacity  |                 |   | 350 + 676         | 1026 W           |
| Water-side temperature difference                                       | Diagram 1       |   |                   | approx. 3 K      |
| Water-side pressure differential  | Diagram 2       |   |                   | approx. 4 kPa    |
| Distance from the diffuser  |                 | $l = x + h_1$                                     | 5 + (2.7 - 1.8)   | 5.9 m            |
| Maximum air velocity at the wall  | Diagram 9       |   |                   | approx. 0.3 m/s  |
| Air velocity in the occupied zone (0.5 m from the wall)                 |                 | approx. 50% of $\bar{v}_1$                        | approx. 0.5 × 0.3 | approx. 0.15 m/s |
| Temperature reduction   | Diagram 9       | $\Delta t_i / \Delta t_{Pr}$                      |                   | 0.28             |
|   |                 | $\Delta t_{Pr} \times \Delta t_i / \Delta t_{Pr}$ | 10 × 0.28         | 2.8 K            |
| Supply air temperature in the occupied zone                             |                 | $t_R - \Delta t_i$                                | 26 - 2.8          | 23.2 °C          |

## Reference values – Cooling

$t_R$  = 26 °C  
 $t_{Pr}$  = 16 °C  
 $t_{WVK}$  = 16 °C  
 $\dot{V}_{WK}$  = 110 l/h

## Reference values – Heating

$t_R$  = 22 °C  
 $t_{Pr}$  = 22 °C (isothermal)  
 $t_{WVH}$  = 50 °C  
 $\dot{V}_{WH}$  = 110 l/h

| $L_N$ | Type of nozzle | Fresh air      |                   |                  | Air-regenerated Noise<br>$L_{WA}$<br>dB(A) | Cooling<br>Two and four pipe system<br>Coil width |                                |                      |                                | Heating<br>Four pipe system<br>Coil width              |  |
|-------|----------------|----------------|-------------------|------------------|--|---|--------------------------------|----------------------|--------------------------------|--|--|
|       |                | $\dot{V}_{Pr}$ |                   | $\Delta p$<br>Pa |  | 256 mm  |                                | 320 mm               |                                | 256 mm<br>$\dot{Q}_{WH}=\dot{Q}_{tot}$<br>(water)<br>W | 320 mm<br>$\dot{Q}_{WH}=\dot{Q}_{tot}$<br>(water)<br>W |
|       |                | l/s            | m <sup>3</sup> /h |                  |  | $\dot{Q}_{tot}$<br>W                              | $\dot{Q}_{WK}$<br>(water)<br>W | $\dot{Q}_{tot}$<br>W | $\dot{Q}_{WK}$<br>(water)<br>W |  |  |
| 900   | G              | 10             | 36                | 78               | 14   | 424   | 303                            | 459                  | 338                            | 545  | 585  |
|       |                | 15             | 54                | 175              | 26   | 612   | 431                            | 628                  | 447                            | 790  | 846  |
|       |                | 22             | 79                | 377              | 37   | 804   | 539                            | 858                  | 593                            | 1006   | 1074   |
|       | U              | 15             | 54                | 54               | 10   | 720   | 353                            | 573                  | 392                            | 638  | 685  |
|       |                | 23             | 83                | 126              | 23   | 738   | 461                            | 786                  | 509                            | 849  | 908  |
|       | 2U             | 32             | 115               | 244              | 33   | 923   | 537                            | 978                  | 592                            | 1003   | 1071   |
|       |                | 26             | 94                | 42               | 12   | 646   | 332                            | 683                  | 369                            | 599  | 643  |
|       |                | 42             | 151               | 108              | 27   | 970   | 464                            | 1018                 | 512                            | 855  | 914  |
|       |                | 50             | 180               | 154              | 32   | 1714  | 508                            | 603                  | 560                            | 943  | 1007   |
| 1200  | G              | 13             | 47                | 74               | 15   | 536   | 379                            | 577                  | 420                            | 689  | 738  |
|       |                | 19             | 68                | 159              | 26   | 755   | 526                            | 808                  | 579                            | 979  | 1046   |
|       |                | 27             | 97                | 321              | 37   | 971   | 645                            | 1033                 | 707                            | 1226   | 1306   |
|       | U              | 19             | 68                | 49               | 11   | 662   | 433                            | 708                  | 479                            | 794  | 849  |
|       |                | 29             | 104               | 114              | 23   | 913   | 563                            | 970                  | 620                            | 1056   | 1127   |
|       | 2U             | 40             | 144               | 216              | 33   | 1135  | 653                            | 1197                 | 715                            | 1242   | 1323   |
|       |                | 32             | 115               | 36               | 15   | 781   | 395                            | 824                  | 438                            | 721  | 772  |
|       |                | 52             | 187               | 96               | 29   | 1187  | 560                            | 1243                 | 616                            | 1049   | 1119   |
|       |                | 62             | 223               | 137              | 34   | 1362  | 614                            | 1421                 | 673                            | 1159   | 1236   |
| 1500  | G              | 16             | 58                | 73               | 17   | 642   | 449                            | 690                  | 497                            | 826  | 884  |
|       |                | 24             | 86                | 164              | 29   | 918   | 629                            | 979                  | 690                            | 1193   | 1271   |
|       |                | 34             | 122               | 329              | 39   | 1171  | 761                            | 1239                 | 829                            | 1475   | 1567   |
|       | U              | 24             | 86                | 50               | 13   | 812   | 523                            | 865                  | 576                            | 973  | 1040   |
|       |                | 36             | 130               | 113              | 25   | 1099  | 665                            | 1162                 | 728                            | 1268   | 1351   |
|       | 2U             | 50             | 180               | 218              | 35   | 1370  | 767                            | 1438                 | 835                            | 1487   | 1580   |
|       |                | 40             | 144               | 38               | 20   | 958   | 476                            | 1007                 | 525                            | 879  | 940  |
|       |                | 55             | 198               | 100              | 35   | 1448  | 664                            | 1510                 | 726                            | 1265   | 1347   |
|       |                | 78             | 281               | 144              | 40   | 1667  | 726                            | 1733                 | 792                            | 1398   | 1486   |

# Water-side capacity

Correction factors – Cooling

| $\dot{V}_{WK}$ in l/h | 70   | 90   | 110  | 130  | 150  | 180  | 220  | 250  | 280  |
|-----------------------|------|------|------|------|------|------|------|------|------|
| $L_N$ 900             | 0.81 | 0.91 | 1.00 | 1.07 | 1.11 | 1.19 | 1.24 | 1.27 | 1.29 |
| $L_N$ 1200            | 0.80 | 0.91 | 1.00 | 1.07 | 1.12 | 1.20 | 1.26 | 1.29 | 1.31 |
| $L_N$ 1500            | 0.79 | 0.91 | 1.00 | 1.08 | 1.13 | 1.21 | 1.28 | 1.31 | 1.34 |

Correction factors – Heating

| $\dot{V}_{WH}$ in l/h | 30   | 40   | 50   | 70   | 90   | 110  | 120  | 140  |
|-----------------------|------|------|------|------|------|------|------|------|
| $L_N$ 900             | 0.68 | 0.76 | 0.83 | 0.91 | 0.96 | 1.00 | 1.02 | 1.04 |
| $L_N$ 1200            | 0.67 | 0.75 | 0.82 | 0.90 | 0.96 | 1.00 | 1.02 | 1.04 |
| $L_N$ 1500            | 0.64 | 0.73 | 0.80 | 0.89 | 0.96 | 1.00 | 1.02 | 1.05 |

## Reference values – Cooling

$t_R$  = 26 °C  
 $t_{Pr}$  = 16 °C  
 $t_{WVK}$  = 16 °C  
 $\dot{V}_{WK}$  = 110 l/h

## Reference values – Heating

$t_R$  = 22 °C  
 $t_{Pr}$  = 22 °C (isothermal)  
 $t_{WVH}$  = 50 °C  
 $\dot{V}_{WH}$  = 110 l/h

### 1 Cooling

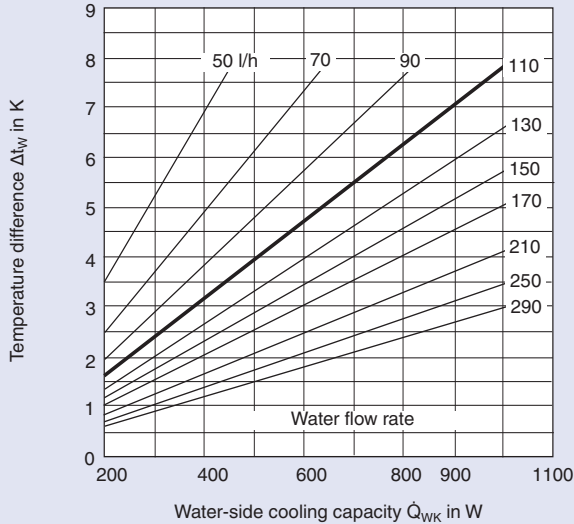

### 3 Heating

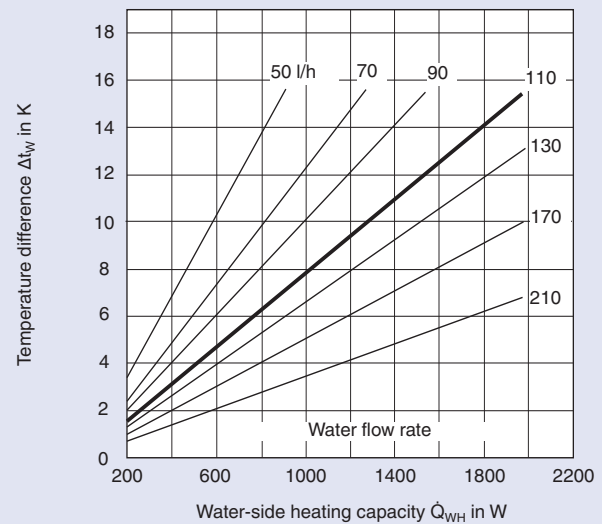

### 2 Cooling

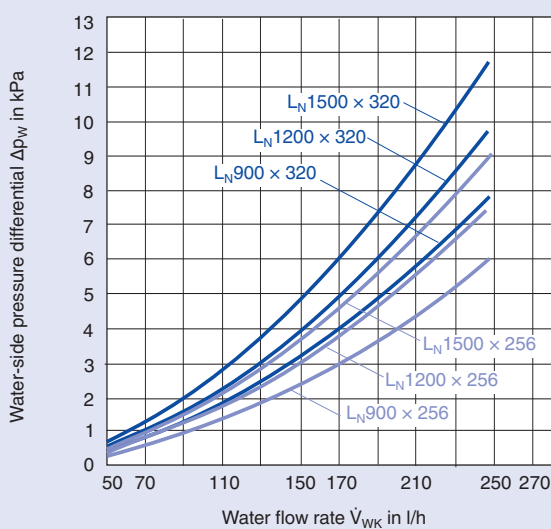

### 4 Heating\*

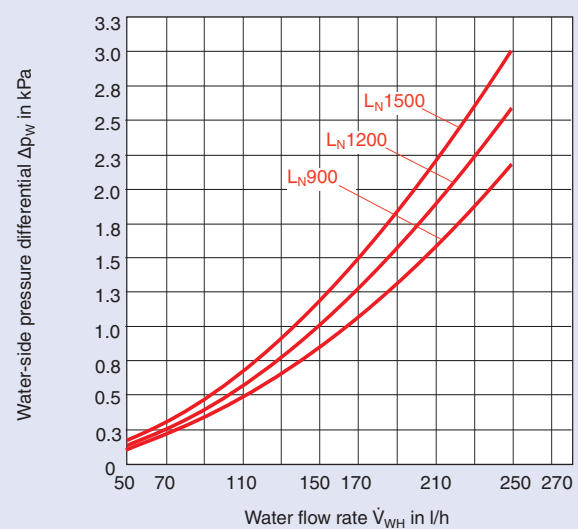

\* For both heat exchanger widths (256/320 mm) for four pipe systems

**5**  $L_N = 900$ , Nozzle type G

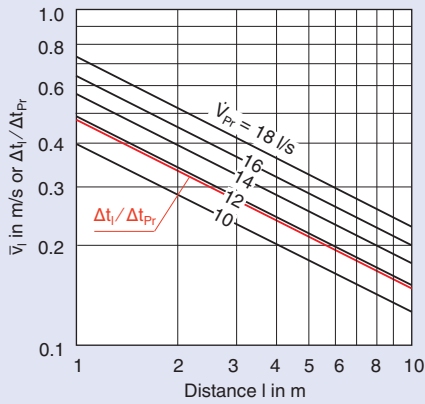

**6**  $L_N = 900$ , Nozzle type U

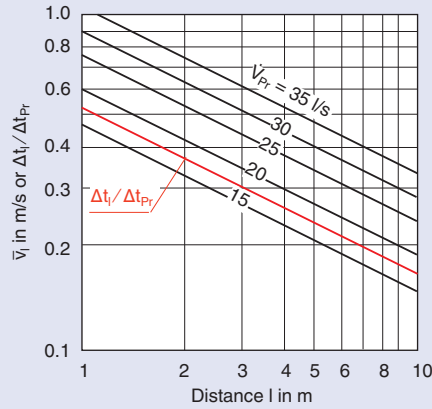

**7**  $L_N = 900$ , Nozzle type 2U

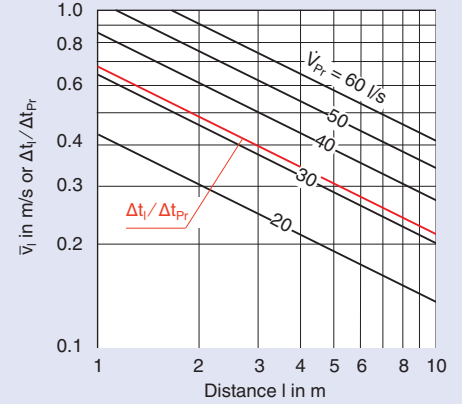

**8**  $L_N = 1200$ , Nozzle type G

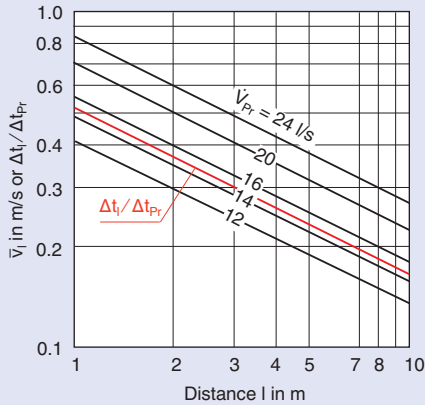

**9**  $L_N = 1200$ , Nozzle type U

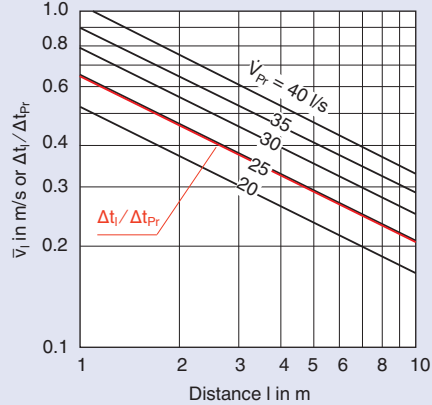

**10**  $L_N = 1200$ , Nozzle type 2U

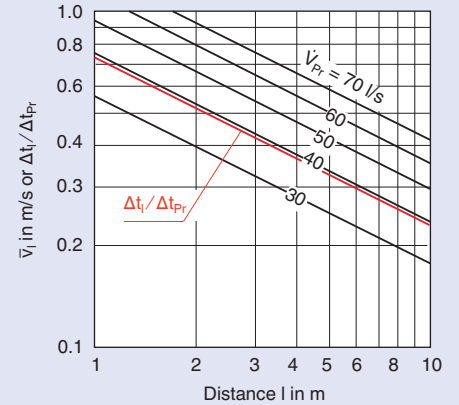

**11**  $L_N = 1500$ , Nozzle type G

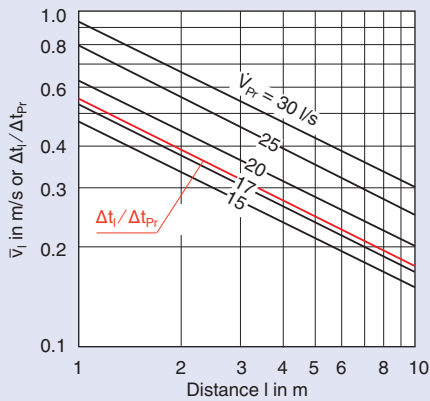

**12**  $L_N = 1500$ , Nozzle type U

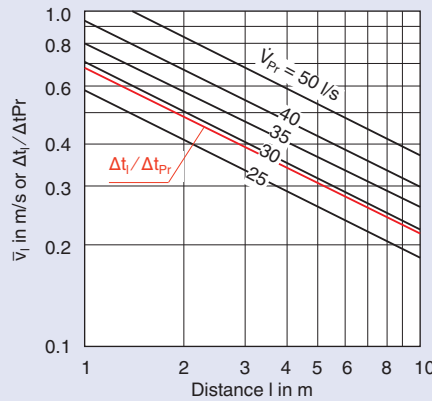

**13**  $L_N = 1500$ , Nozzle type 2U

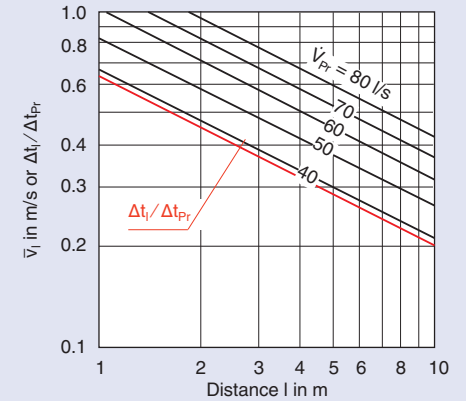

The tabulated air velocities  $\bar{v}_i$  and  $\bar{v}_{h1}$  are based on a regular distribution of heat loads in the space. Strong asymmetric distribution will result in variations to the tabulated values.

# Order Details



## Specification text

Active chilled beams with one way air discharge and high thermal capacities using air-water systems. Suited for hotel bedrooms, individual hospital wards and cellular offices. Consisting of a casing with suspension holes, connecting spigot, non-combustible nozzles, and heat exchanger.

### Special characteristics

- Low height construction
- Heat exchangers for two or four pipe systems
- Nozzles punched in sheet metal plate, non-combustible
- Many options of induced and supply air grille design

Nozzles in two sizes to optimise induction, additionally one of these in a two-row configuration. Water-side connecting tails with 12 mm outer diameter plain end.

### Beam variant:

Water-side connecting tails external threaded G1/2", flat end seal.

## Materials

Casing and nozzle plate made of galvanised sheet steel. Heat exchanger made of copper tubes and formed aluminium fins.

Optional induced (IS) and supply (AS) air spigots made of galvanised sheet steel.

Surfaces of the casing and the heat exchanger option, finish black (RAL 9005)

## Order code

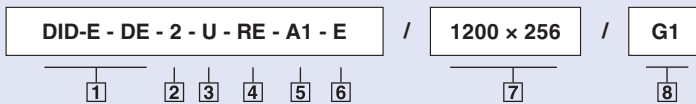

### 1 Type

### 2 Heat exchanger

- 2 Two pipe system
- 4 Four pipe system

### 3 Nozzle variant

- G
- U
- 2U

### 4 Arrangement of the water connections

- RE Right
- LI Left

### 5 Water connections

- Pipe end Ø12 mm, smooth, no entry required
- A1 External thread G1/2", flat end seal

### 6 Vent valve

- None, no entry required
- E With vent valve

### 7 Nominal length x Width of heat exchanger

- 900 x 256
- 900 x 320
- 1200 x 256
- 1200 x 320
- 1500 x 256
- 1500 x 320

### 8 Surface

- Casing and heat exchanger
- Untreated, no entry required
- G1 Black (RAL 9005)

## Accessories

- |           |                                |
|-----------|--------------------------------|
| DID-E -IS | Induced air spigot             |
| DID-E -AS | Supply air spigot              |
| DID-E -IA | Induced and supply air spigots |

Ventilation grilles to be ordered separately see TROX leaflet no. T 1.1/1/D/... see HESCO leaflet no. L-02-1-01

## Order example

Make: TROX  
 Type: DID-E -2 -U -RE -A1 -E / 1200 x 256 / G1

## Order example accessory

Make: TROX  
 Type: DID-E -IA / 1200 x 256 / G1