

Ceiling Diffusers

- Type ADLQL
- recommended for room heights from 2.60 m to 4.00 m

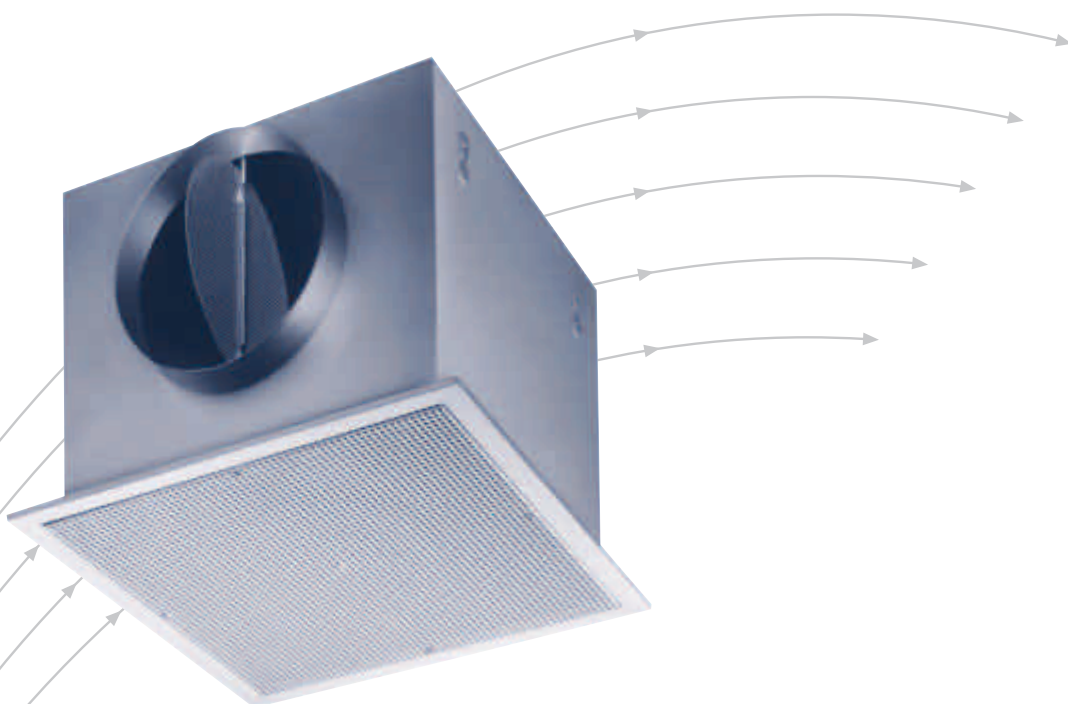

TROX[®] TECHNİK

TROX UK Ltd
Caxton Way
Thetford
Norfolk IP24 3SQ

Telephone +44 (0)1842 754545
Telefax +44 (0)1842 763051
e-mail trox@troxuk.co.uk
www.troxuk.co.uk

Contents · Description

Contents · Description	2
Construction · Dimensions	3
Materials	3
Directions of discharge · Blanking plates	4
Nomenclature	5
Acoustic Data	5
Aerodynamic Data	9
Order Details	10

ADLQL- ... -H Construction

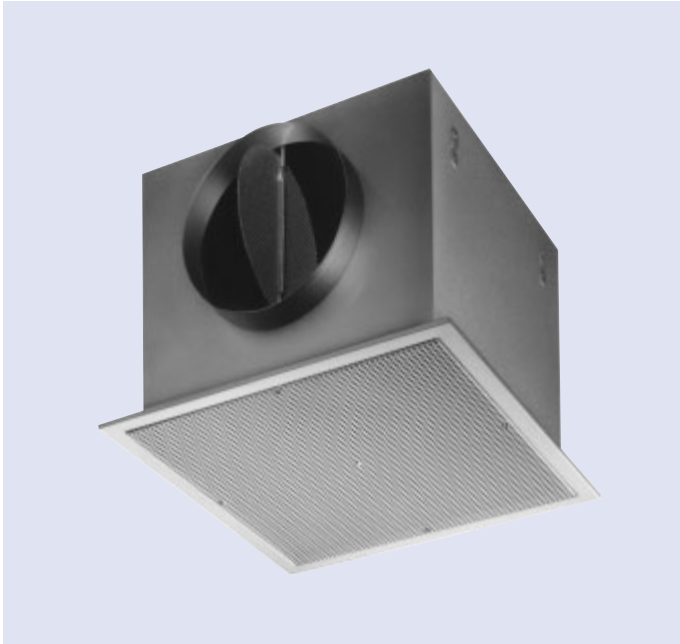

ADLQL- ... -V Construction



Type ADLQL ceiling diffusers are ideal for flush installation in tiled ceilings. They are recommended for room heights between 2.60 m and 4.00 m. They are characterised by high induction, which results in rapid decay of supply air velocity and temperature differential. The recommended supply air temperature differential range is ± 10 K.

Construction · Dimensions · Materials

Construction

Type ADLQL ceiling diffusers comprise a diffuser face fitted with rear plenum box. The diffuser face has a border width of either 11 mm for flush mounting into tiled ceilings or 30 mm so that the border is surface mounted covering the ceiling opening, for example in plaster ceilings.

The plenum box can be supplied with circular spigots top or side entry. The side entry plenum box can also be provided with internal acoustic lining and/or volume control damper operable from the diffuser face (core removed).

Materials

The face border and neck section are fabricated from aluminium extruded section.

The perforated face panel with return edges, side entry plenum, top entry spigot plate and all internal baffles and deflector plate are from galvanised sheet steel. The internal acoustic lining is 12mm thick foam - Class 0.

The perforated face and border face are finished in RAL 9010 20% Gloss, colours available on request.

D _A Nom	D	Q ₁	Q ₂	K ₁	H ₁	K ₂
300	158	336	298	274	297	269
400	198	436	398	374	337	369
500	248	536	498	474	387	469
600	313	636	598	574	452	569
295*	148	-	295	271	297	266
595*	313	-	595	571	452	566

* Dimensions for diffuser to suit 'T' bar ceiling.
These dimensions apply to ADLQL-P-ZH and ADLQL-P-ZV only.

Type ADLQL (ADLQL-K-ZH-D-M shown)

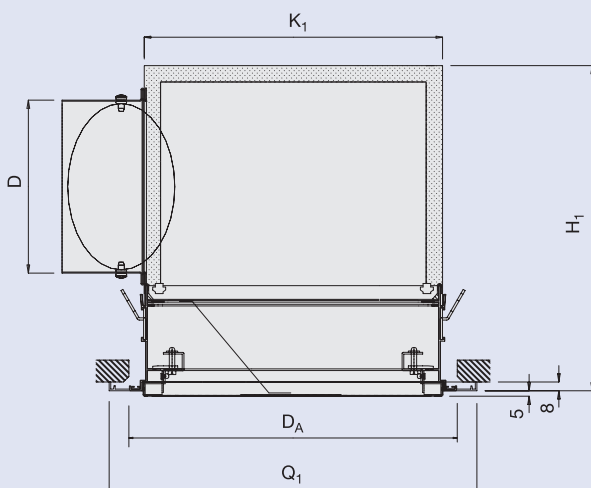

Type ADLQL (ADLQL-P-ZH-D-M shown)

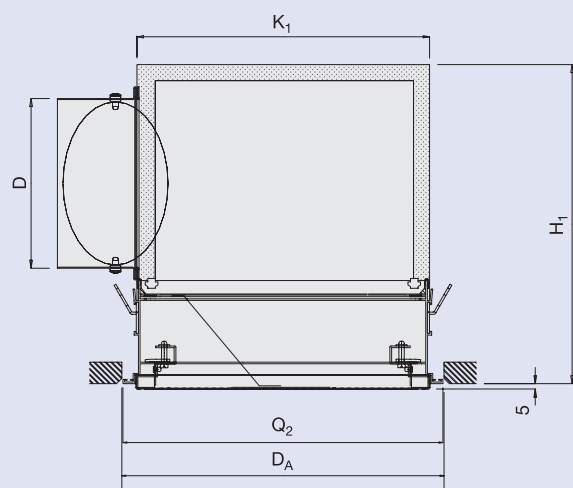

Type ADLQL (ADLQL-K-ZV shown)

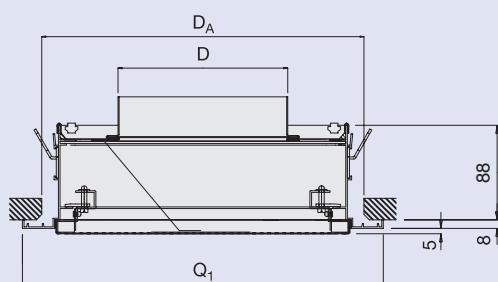

Type ADLQL (ADLQL-P-ZV shown)

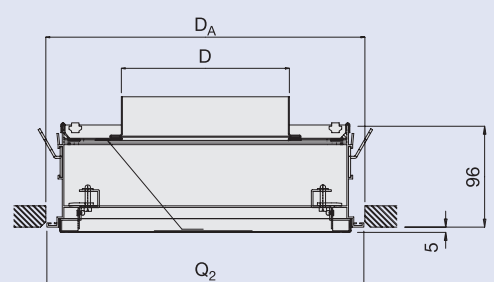

Directions of Discharge · Blanking plates

Blanking Plates

To provide various directions of discharge, blanking plates can be supplied on request.

To mount these plates, the perforated sheet face must be removed. The blanking plate is fixed to the plenum box using self-tapping screws.

The fitting is by others on site.

Blanking Plates

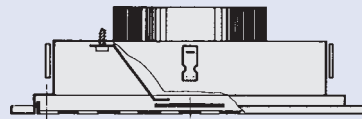
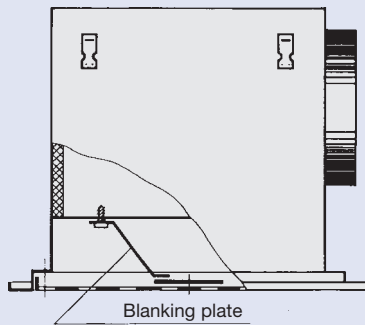

Directions of discharge

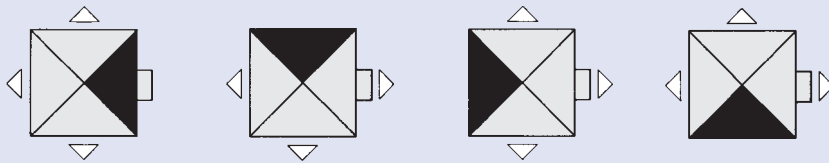

1 Blanking plate required per diffuser

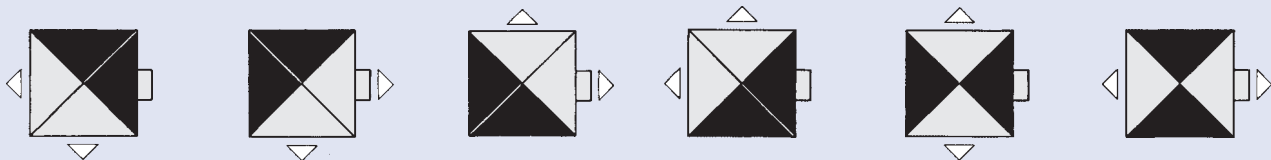

2 Blanking plates required per diffuser

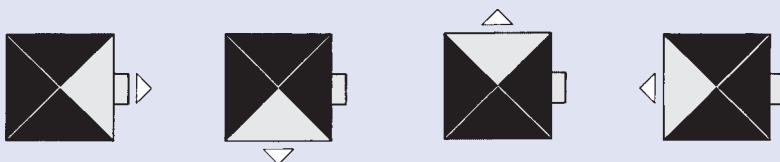

3 Blanking plates required per diffuser

Nomenclature · Acoustic Data

Nomenclature

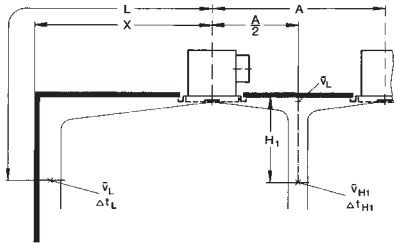

- in l/s: Volume flow per diffuser
 - in m³/h: Volume flow per diffuser
 - ⁴ in l/s: Volume flow for 4 way discharge diffuser
 - ⁴ in m³/h: Volume flow for 4 way discharge diffuser
- For 3-; 2-; 1-; way discharge enter diagrams using the following:
- 3 way: $\frac{4}{4} = 1.33$
 - 2 way: $\frac{4}{4} = 2.0$
 - 1 way: $\frac{4}{4} = 4.0$
- A in m: Spacing between two diffusers
 - H₁ in m: Distance between ceiling and occupied zone

- L in m: Distance from diffuser $L = X + H_1$
- \tilde{v}_L in m/s: Time average air velocity at the wall at distance L
- \tilde{v}_{H1} in m/s: Time average air velocity between two diffusers at distance H₁ from ceiling
- v_o in m/s: Air velocity in inlet spigot
- Δt_Z in K: Temperature difference between supply and room air
- Δt_L in K: Difference between core and room temperature at distance $A/2 + H_1$ or $L = X + H_1$
- Δp_t in Pa: Total pressure drop
- L_{WA} in dB(A): A-weighted sound power level
- L_{WNC}: NC rating of sound power level
- L_{WNR}: $L_{WNR} = L_{WNC} + 2$
- ΔL in dB/oct.: Relative level with respect to L_{WA}
- L_W in dB/oct.: Octave band sound power level of regenerated noise $L_W = L_{WA} + \Delta L$
- L_{pA}, L_{pNC}: A-weighting and NC rating respectively of room sound pressure level $L_{pA} \approx L_{WA} - 8 \text{ dB}$
 $L_{pNC} \approx L_{WNC} - 8 \text{ dB}$

1 Relative level and octave band centre frequency Type ADLQL- ...-V

Note: ¹⁾ Size 295 and size 595 performance is the same as size 300 and size 600 respectively

$$\dot{V} [\text{m}^3/\text{h}] = \dot{V} [\text{l/s}] \times 3.6$$

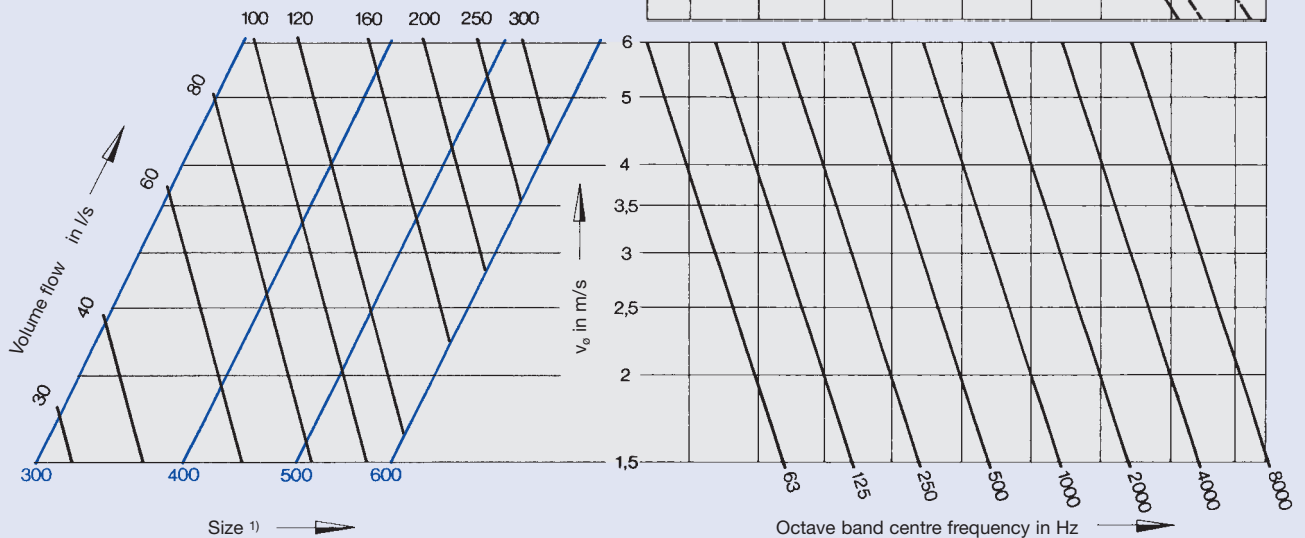

Acoustic Data

Insertion loss in dB/octave with internal lining
(includes end reflection loss)

Size	Octave band centre frequency in Hz							
	63	125	250	500	1000	2000	4000	8000
300	15	15	8	16	18	15	15	15
400	12	12	10	16	16	14	14	14
500	10	10	11	16	14	14	14	14
600	8	8	13	16	12	13	13	13

Insertion loss in dB/octave without internal lining
(includes end reflection loss)

Size	Octave band centre frequency in Hz							
	63	125	250	500	1000	2000	4000	8000
300	15	15	6	10	13	7	5	5
400	12	12	8	10	11	6	5	5
500	10	10	9	9	8	6	5	5
600	8	8	9	9	5	5	5	5

2 Sound power level and pressure drop
Supply air type ADLQL- ... -V

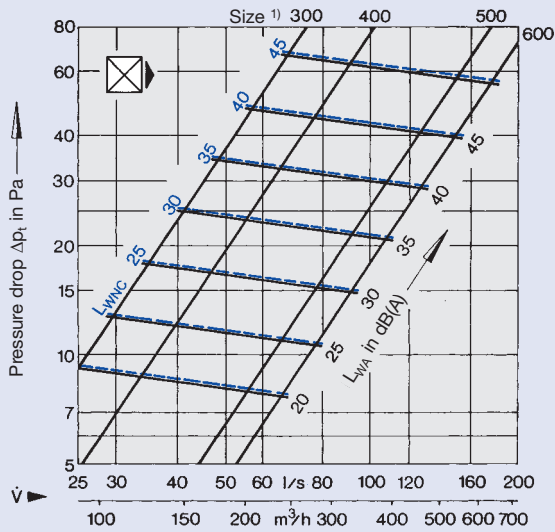

4 Sound power level and pressure drop
Supply air type ADLQL- ... -V

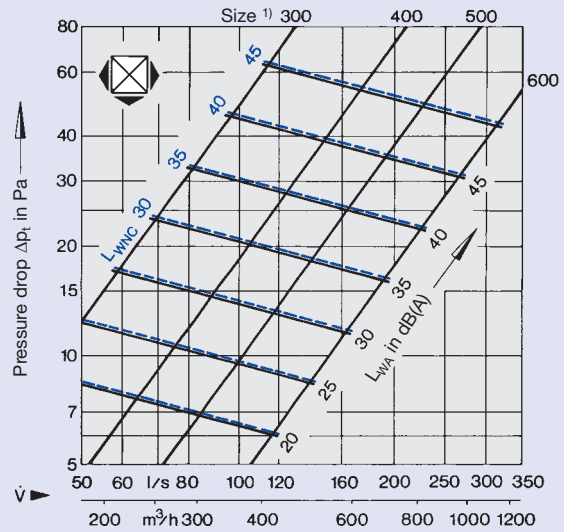

3 Sound power level and pressure drop
Supply air type ADLQL- ... -V

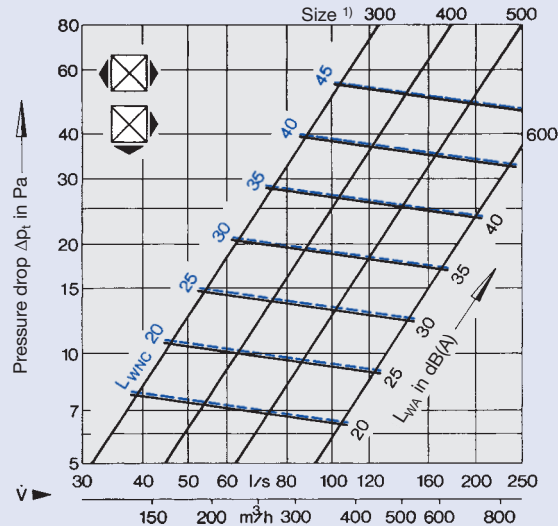

5 Sound power level and pressure drop
Supply air type ADLQL- ... -V

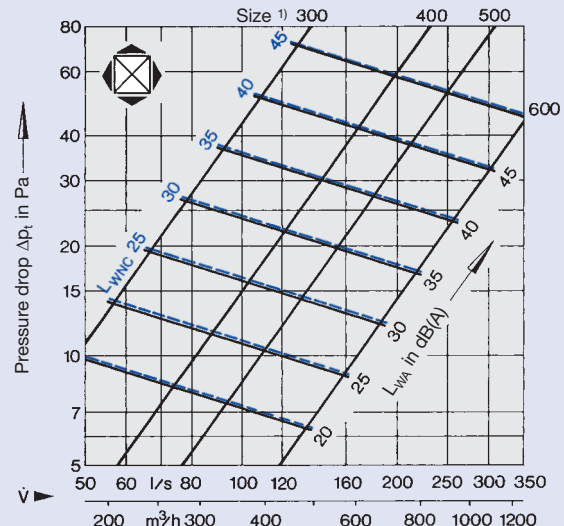

Note: ¹⁾ Size 295 and size 595 performance is the same as size 300 and size 600 respectively

Example

Data given:

Type ADLQL-...-H; Size 400

Volume flow with 4 way discharge = 110 l/s

Damper angle $\approx 30^\circ$

Required: Octave sound power level of regenerated noise L_w

Diagram 12: Sound power level and pressure drop

$$L_{WA} = 46 \text{ dB(A)}$$

$$\Delta p_t = 38 \text{ Pa}$$

$$v_o = 3.6 \text{ m/s}$$

Correction from table:

$$L_{WA} = -4 \text{ dB(A)}$$

$$L_{WA} = 46 - 4 = 42 \text{ dB(A)}$$

Diagram 7:

Octave band frequency in Hz	63	125	250	500	1000	2000	4000	8000
L_{WA} in dB(A)	42	42	42	42	42	42	42	42
ΔL in dB(A)	-5	+3	-3	-7	-3	-9	-18	-28
L_w in dB	37	45	39	35	39	33	24	14

6 Sound power level and pressure drop
Extract air type ADLQL-...-V

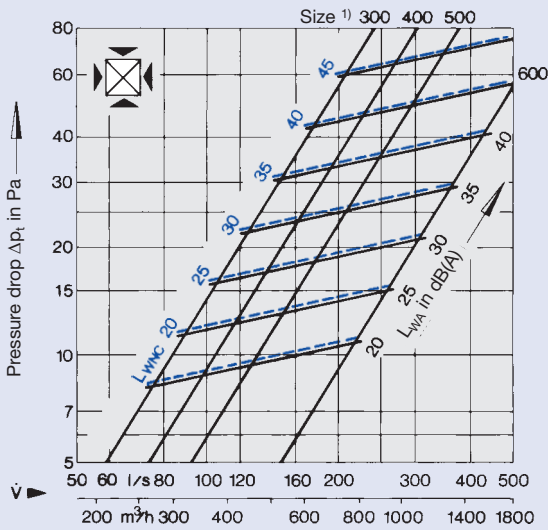

7 Relative level and octave band centre frequency type ADLQL-...-H

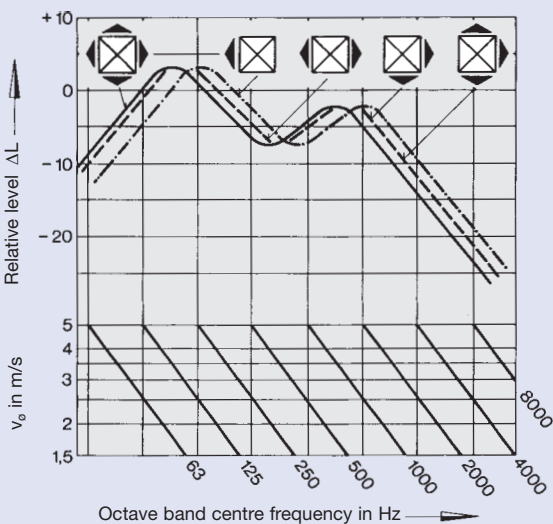

Note: 1) Size 295 and size 595 performance is the same as size 300 and size 600 respectively

8 Sound power level and pressure drop
Extract air type ADLQL-...-H

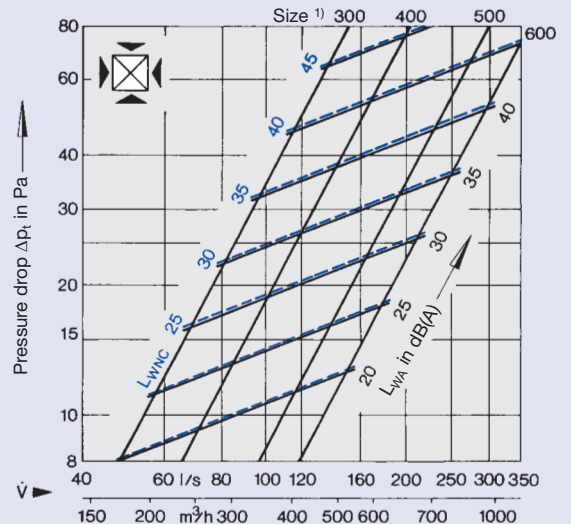

Acoustic Data

Correction to diagrams 9 – 12

Size	300	400	500	600
L_{WA}	-6	-4	-2	0
L_{WNC}				

9 Sound power level and pressure drop
Supply air type ADLQL- ... -H

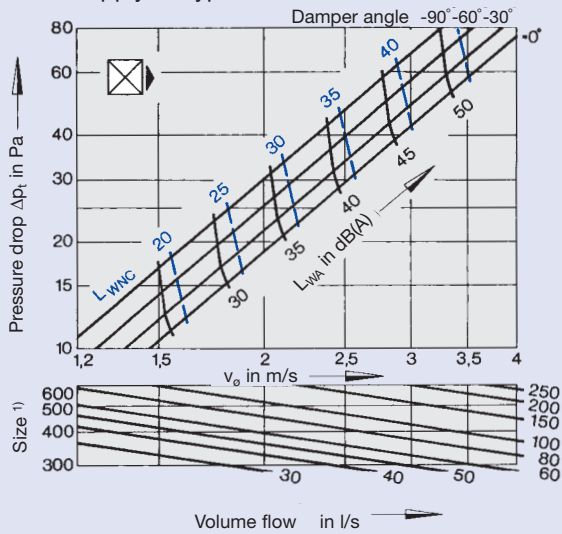

11 Sound power level and pressure drop
Supply air type ADLQL- ... -H

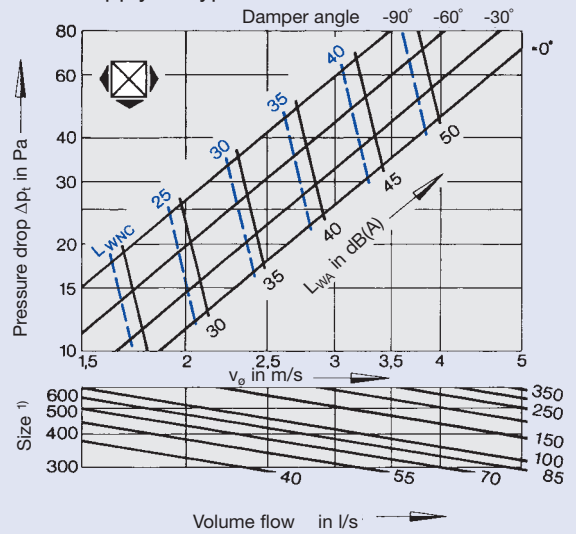

10 Sound power level and pressure drop
Supply air type ADLQL- ... -H

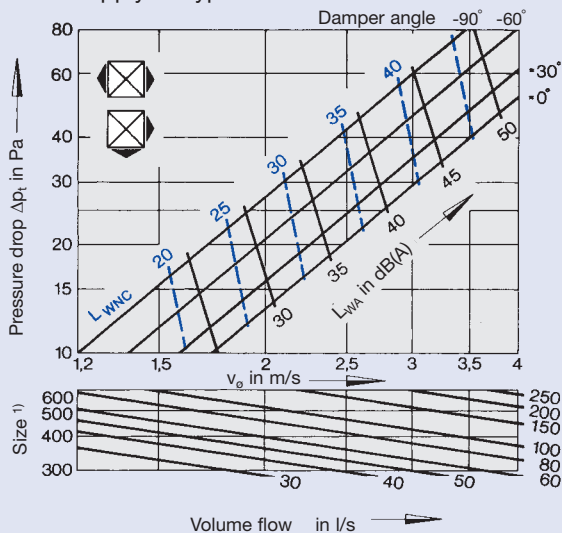

12 Sound power level and pressure drop
Supply air type ADLQL- ... -H

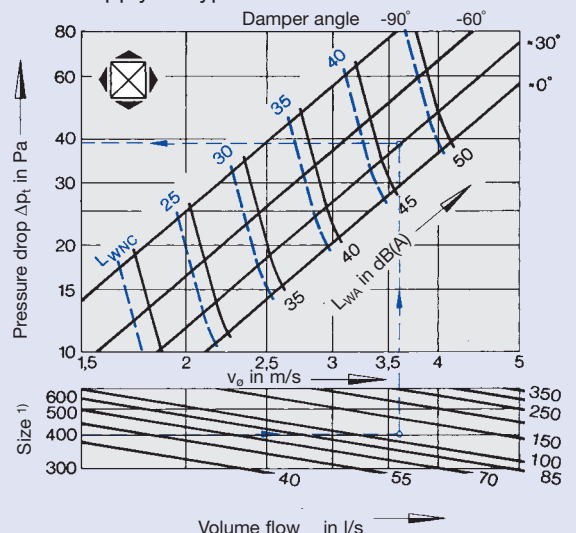

$$\dot{V} \text{ [m}^3\text{/h]} = \dot{V} \text{ [l/s]} \times 3.6$$

Note: ¹⁾ Size 295 and size 595 performance is the same as size 300 and size 600 respectively

Example

Data given:

Type ADLQL; Size 300

Volume flow 2 way discharge

= 40 l/s

Spacing 1 between 2 diffusers

A = 2.8 m

Distance between ceiling and occupied zone

H₁ = 1.2 m

Diagram 13: Air velocity at the wall and temperature quotient

$$V_4 = 2 \cdot$$

$$= 2 \cdot 40 = 80 \text{ l/s}$$

$$A/2 = 1.4 \text{ m}$$

$$\tilde{v}_L = 0.37 \text{ m/s}$$

$$L = 1.2 + 1.4 = 2.6 \text{ m}$$

$$\Delta t_L / \Delta t_z = 0.1$$

Diagram 14:

Air velocity between two diffusers

$$\tilde{v}_{H1} = 0.17 \text{ m/s}$$

13 Air velocity at the wall and temperature quotient

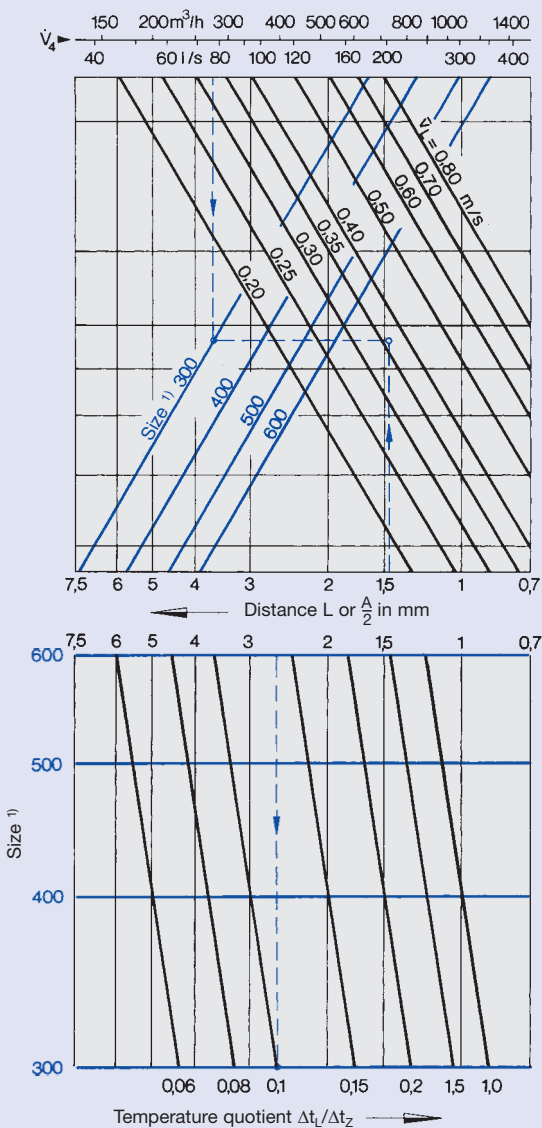

Note: ¹⁾ Size 295 and size 595 performance is the same as size 300 and size 600 respectively

Effective outlet area

Size	300	400	500	600
A _{eff} in m ²	0.0140	0.0254	0.0360	0.0600

14 Air velocity between two diffusers

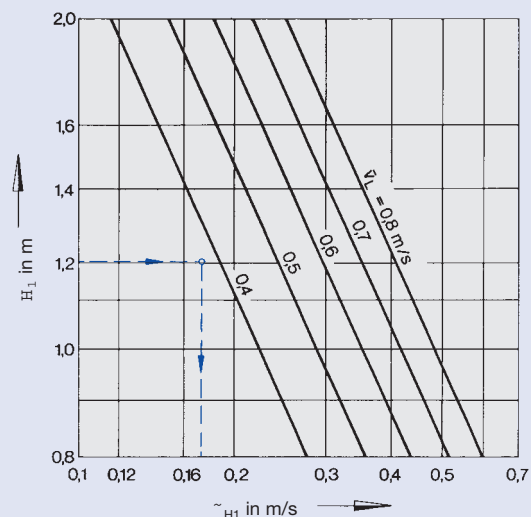

Order Details



Order Code

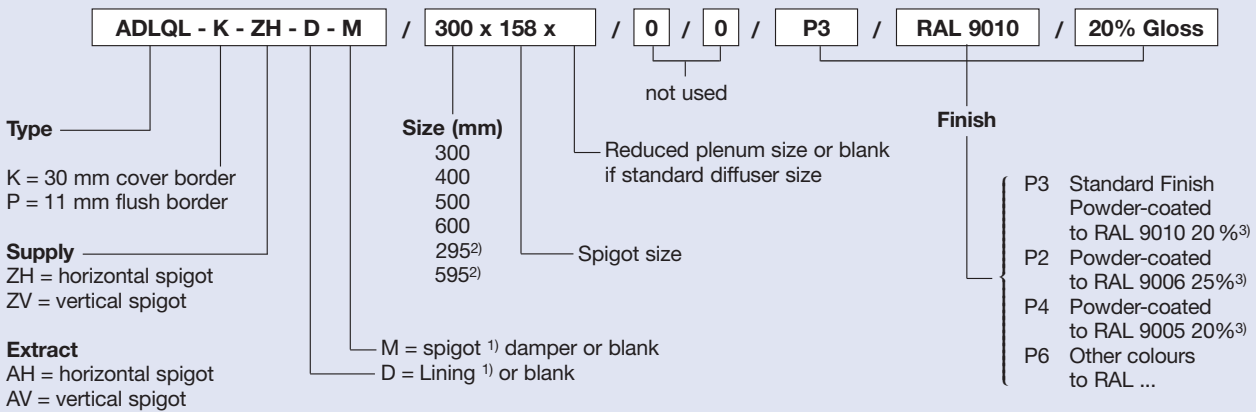

Order Code

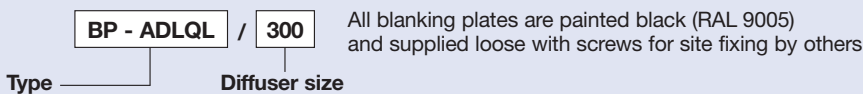

Note: 1) Only available for horizontal spigot
 2) Only available for flush border & layin "T" bar
 3) % = Gloss level

Specification Text

Square ceiling diffuser for horizontal discharge, comprising face section and border which is either 30 or 11 mm wide. Screw fixed perforated plate core with returned edges complete with fitted baffle plate. Also with rear plenum box with internal baffle with circular top or side entry spigots, optional items volume control damper and internal acoustic lining. Plenum box is firmly riveted to the diffuser face, 4 suspension brackets provided to hang assembly from ceiling slab.

Materials:

Face border and neck section are fabricated from aluminium extruded section. Perforated face panel with return edges, side entry plenum, top entry spigot plate and all internal baffles and deflector plate are manufactured from galvanised sheet steel. The internal acoustic lining is 12mm thick foam - Class 0.

Finish

Perforated face and border face are finished in RAL 9010 20% gloss. Plenum and top tray sections will be natural. Deflectors and centre baffle plate disc will be painted matt black.

Order Example

Make: TROX
 Type: ADLQL-K-ZH-D-M/300x158/0/0/P3/RAL9010/20% Gloss
 Accessories: BP-ADLQL/300