

Grilles

Linear Grilles



TROX[®] TECHNİK

Trox (U.K.) Ltd
Caxton Way
GB-Thetford
Norfolk IP24 3SQ

Telephone +44 (0)1842 754545
Telefax +44 (0)1842 763051
www.troxuk.co.uk
e-mail: trox@troxuk.co.uk

Contents · Description

Description	2	Rear Assemblies	15
Aluminium Grilles - Construction · Dimensions · Materials	3	Rear Assemblies - Grilles · Linear Grilles	16
Aluminium Grilles & Grille Cores - Construction · Dimensions	4	Fixing Details	17
Aluminium Grilles - Construction · Dimensions	5	Installation Details	18
Steel Grilles Construction · Dimensions · Materials	6	Installation Subframe	19
Stainless Steel Grilles · Flow Rate Control Dampers Construction · Dimensions · Materials	7	Nomenclature · Acoustic Data	21
Plastic Grilles - Construction · Dimensions · Materials	8	Acoustic Data for Supply Air	22
Special Filter Frame - Construction · Dimensions · Materials ..	9	Acoustic Data for Return Air Grilles	23
Grilles & Linear Grille Cores - Dimensions	10	Aerodynamic Data - Grilles	25
Aluminium Grilles · Dimensions	11	Effective Outlet Area	26
Aluminium Linear Grilles · Construction · Dimensions · Materials	12	Aerodynamic Data - Grilles	28
Steel Linear Grilles · Construction · Dimensions · Materials	13	Aerodynamic Data - Linear Grilles	30
Selection Tables for Linear Grille Lengths	14	Aerodynamic Data - Linear Grilles with Ceiling Effect	31
		Aerodynamic Data - Linear Grilles	32
		Aerodynamic Data for Return Air Grilles	33
		Order Details	36



Grilles and linear grille designs are available for duct, wall and floor installation. They may be fitted directly into the duct section or alternatively an installation subframe may be used, eg : for installation into builders work.

To optimise air distribution, it is possible to choose from different types of rear assemblies, see pages 15 and 16.

Aluminium Grilles

Construction · Dimensions · Materials

Construction

Type ASL

Supply or return air grille. The front border has a diffuser-type section, with individually adjustable horizontal front blades and a concealed fixing for use with a sub-frame. Available on request with spring clip fixing. Standard finish: Natural anodised to E6 - C - 0.

Type AT

Supply or return air grille with individually adjustable horizontal aerofoil blades. Front border 32mm wide with visible screw fixing (border counter punched). Available on request with concealed fixing. Standard finish: Powder coated RAL 9010 20% gloss.

Type VAT

Supply or return air grille with individually adjustable vertical aerofoil blades. Front border 32mm wide with visible screw fixing (border counter punched). Available on request with concealed fixing. Standard finish: Powder coated RAL 9010 20% gloss.

Materials

The grilles are made from extruded aluminium sections. Standard finish: Powder coated RAL 9010 20% gloss (refer to construction for exceptions).

Type ASL

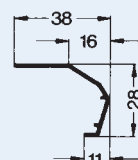
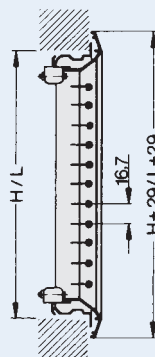
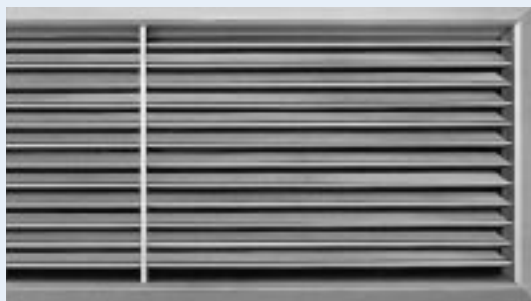

A1 / 0 Fixing Shown

Type AT

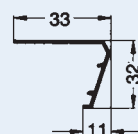
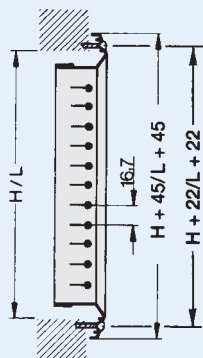
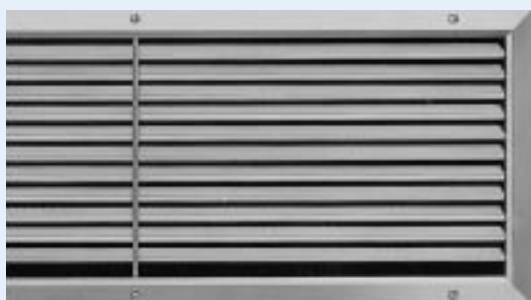

0 / 0 Fixing Shown

Type VAT

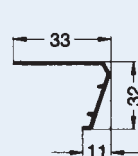
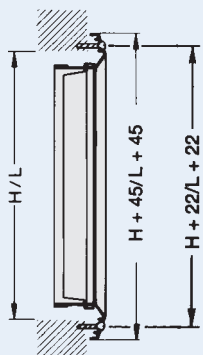
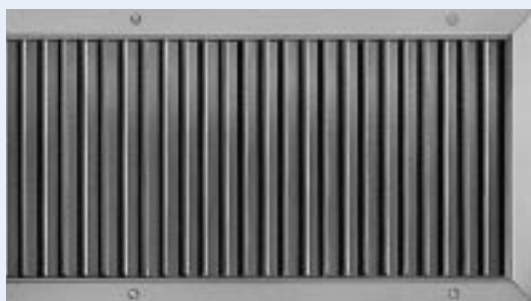

Blade pitch 16.7 mm



0 / 0 Fixing Shown

Aluminium Grilles and Grille Cores

Construction · Dimensions

Types AH

Supply or return air grille with fixed horizontal profiled blades on 12.5mm pitch. Front border 30mm wide, 5.5mm blades with either 0° or 15° deflection, Types AH-0 and AH-15 respectively, with visible screw fixing (border counter punched). Available on request with concealed fixing. Standard finish: Powder coated RAL 9010 20% gloss.

Type WAP

Supply or return air grille with fixed horizontal profiled blades. As type AH but 3mm blades on 12.5mm pitch. Standard finish: Powder coated RAL 9010 20% gloss.

Type AF

Supply or return air grilles for lay in floor mounting with fixed horizontal profiled blades, blades with either 0° or 15° deflection, Type AF-0 and AF-15 respectively. The grille core can be removed by releasing the W clips. The grille can be fitted into masonry. Standard finish: Powder coated RAL 9006 25% gloss (white aluminium).

Type EH · EW

Grille cores for supply or return air, for wall or sill mounting with fixed horizontal blades. Available with 5.5mm blades on 12.5mm pitch with either 0° or 15° deflection, Type EH-0 or EH-15 respectively, or with 3mm wide blades on 12.5mm pitch - Types EW-0 or EW-15. Powder coated RAL 9010 20% gloss.

Types AHR · WAPR

As type AH · WAP but with 20mm wide border in lieu of 30mm wide border.

Type AH

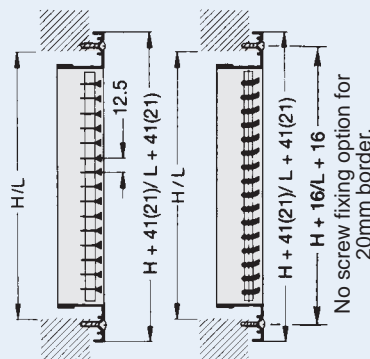
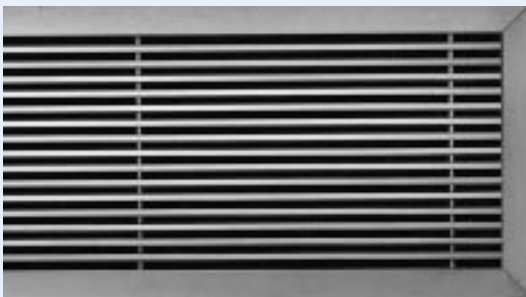

x () - for WAP
* for () dimension Type AHR with 20mm border

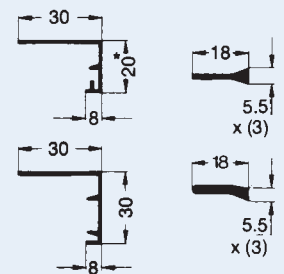

AH-0 AH-15
WAP-0 WAP-15

0 / 0 Fixing Shown

Type AF

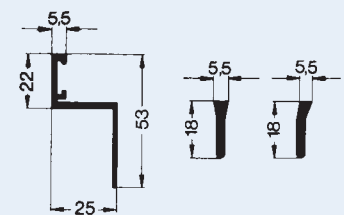
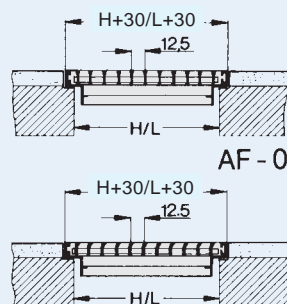

- / - Fixing Shown

Type EH · EW

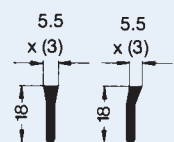
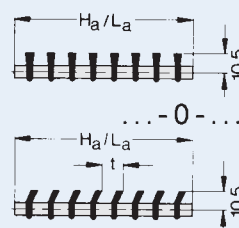
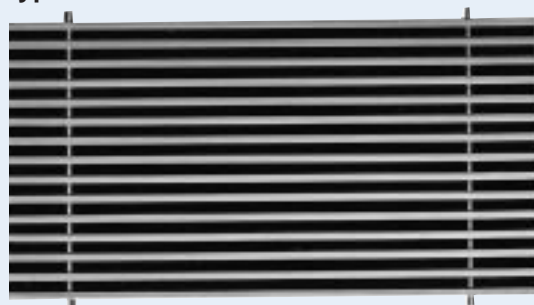

... - 15 - ...

Aluminium Grilles

Construction · Dimensions

Type AWT

Grille for installation in gymnasias and sports halls has a ball impact resistance conforming to DIN 18032 Part 3.

Robustly constructed supply or return air grille with fixed horizontal profiled blades with visible screw fixing (border counter punched). Standard finish: Natural anodised to E6 - C - 0.

Type AGS

Non vision grille for supply or return air with fixed inverted vee blades with visible screw fixing (border counter punched). The non vision grille is also available as Type AGS-T with rear frame see page 17. Standard finish: Powder coated RAL 9010 20% gloss.

Type AWT

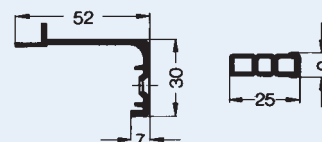
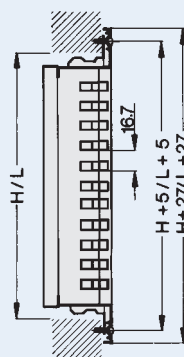

A1 / 0 Fixing Shown

Type AGS

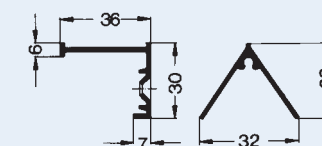
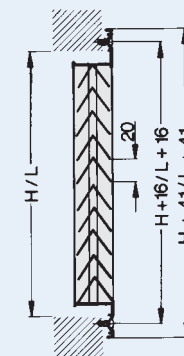

0 / 0 Fixing Shown

Steel Grilles

Construction · Dimensions · Materials

Construction

Type SL

Supply or return air grille. The front border has a diffuser-type section (L side 28mm wide, H side 20mm wide) with individually adjustable horizontal front blades and concealed fixing for use with a sub-frame.

Type TR

Supply or return air grille with individually adjustable horizontal front blades with visible screw fixing (border counter punched). Available on request with galvanised finish and concealed fixing.

Type TRS

Supply or return air grille with individually adjustable vertical front blades with visible screw fixing (border counter punched). Available on request with concealed fixing.

Materials Type SL · TR · TRS

The grille face is made from formed sheet steel. The surface is pre-treated and powder coated (RAL 9010 50% gloss).

Materials Type TR - Galvanised (optional)

The grille face is made from formed, galvanised sheet steel.

Type SL

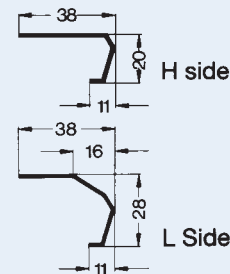
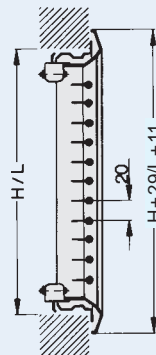

M1 / 0 Fixing Shown

Type TR

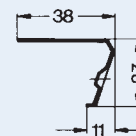
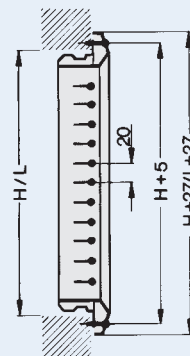

A1 / 0 Fixing Shown

Type TRS

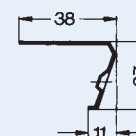
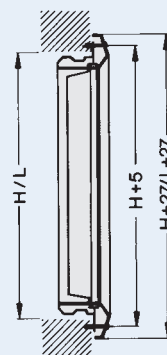
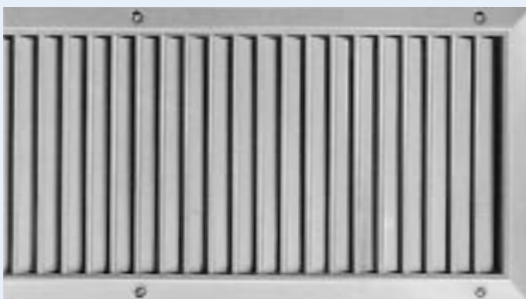

Blade pitch
20 mm

A1 / 0 Fixing Shown

Stainless Steel Grilles · Flow Rate Control Dampers

Construction · Dimensions · Materials

Construction

Type TRE

Supply or return air grilles with individually adjustable horizontal front blades with visible screw fixing (border counter punched).

Type AGW

Flow rate control damper for duct installation, opposed blade action adjustable from the face, angle border.

Standard sizes see page 10.

Type DGW

Flow rate control damper for duct installation, opposed blade action adjustable from the face, plus a set of individually adjustable vertical air pattern control blades, angle border.

Standard sizes see page 10.

Materials Type TRE

The grille face is made from formed, stainless sheet steel (DIN ref. 1.4301 or higher). The material has a dull, pickled surface. A bright surface is available on request.

Materials Type AGW · DGW

The damper is made from formed sheet steel. The surface is stove enamelled black (RAL 9005) using electro-dipping process.

Type TRE



L in mm	F in mm
225	—
325	—
425	—
525	—
625	283,5
775*	358,5

* L = 775 Face blades sub-divided by separating bar.

Border section

Counter punched holes $\varnothing 4,8 \times 90^\circ$
raised counter sunk head self tapping
screws $\varnothing 3,9 \times 13$ (by others)

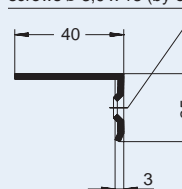

Horizontal front blade

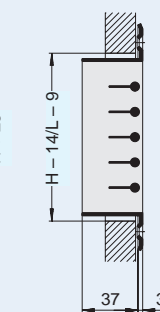
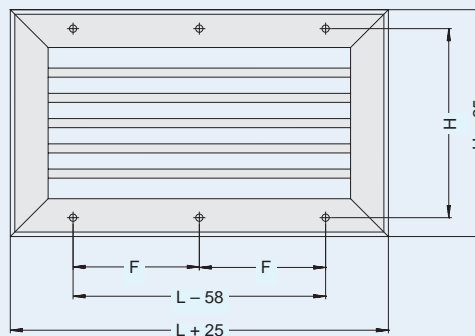
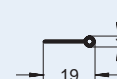

Blade pitch 16,7 mm

Type AGW · DGW

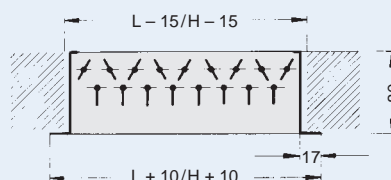
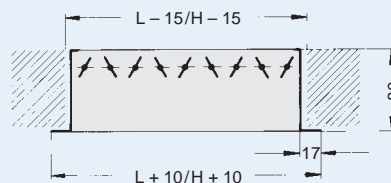

Plastic Grilles

Construction · Dimensions · Materials

Construction

Type KS

Type KS grilles are suitable for supply and extract use. The grille has an injection moulded border with holes (\varnothing 4.5mm) for site fixing with suitable screws.

Type KS-A

Horizontal face blades which are individually adjustable.

Type KS-C

As Type KS-A but with additional individually adjustable vertical curved blades at rear for volume control.

Materials

Grille face and rear assemblies made from plastic extrusions (hard PVC) with good anti-corrosive properties, temperature resistant up to 50°C. Dark grey grille face (similar to RAL 7011), curved blades for volume control in black or dark grey.

Type KS

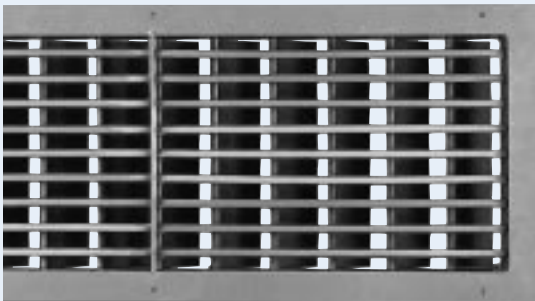

Vertical curved blade C

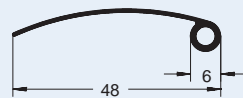

Horizontal face blade

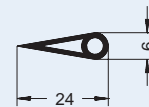

Type KS-A

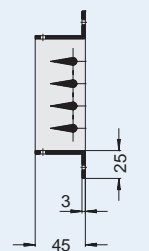
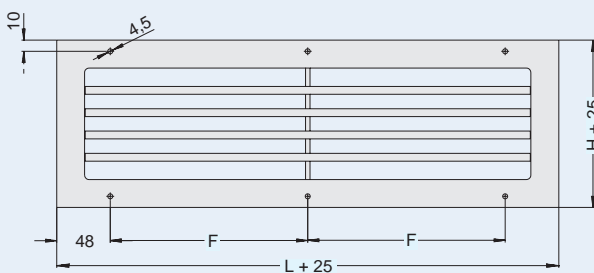

Blade pitch 20 mm

Type KS-A

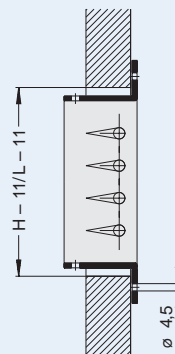

Type KS-C

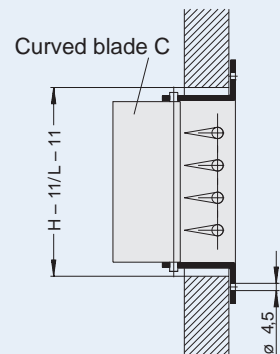

Fix with suitable screws provided by others

Type KS-C

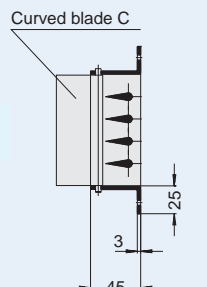
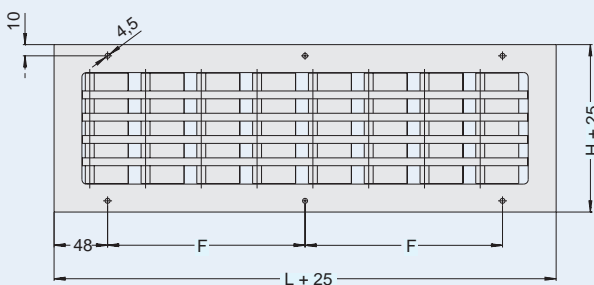

Blade pitch 20 mm

L in mm	F in mm
325	—
425	—
625	277
825	377

L = 625 Face blades sub divided by separating bar

L = 825 Face blades sub divided twice by separating bar

Special Filter Frame

Construction · Dimensions · Materials

Construction

Type ...EF

For wall installation, the standard ...-A construction in the types SL, TR and TRS grilles are available with the ...A-EF special frame with filter pad or, alternatively, with an additional special hit and miss damper, type ...-AS-EF (construction see page 16).

The grille and special frame with filter pads are connected by spring clip fastening. The special frame with filter pad is available with $H = 125\text{mm}$ to $H = 525\text{mm}$.

Spare E-EF filter media is available on request..

Materials

The special filter frame is made from formed sheet steel. The surface is phosphate treated and stove enamelled black (RAL 9005) using electro dipcoat process. The filter pad consists of synthetic chemical fibres, quality grade EU4.

Type ...-EF

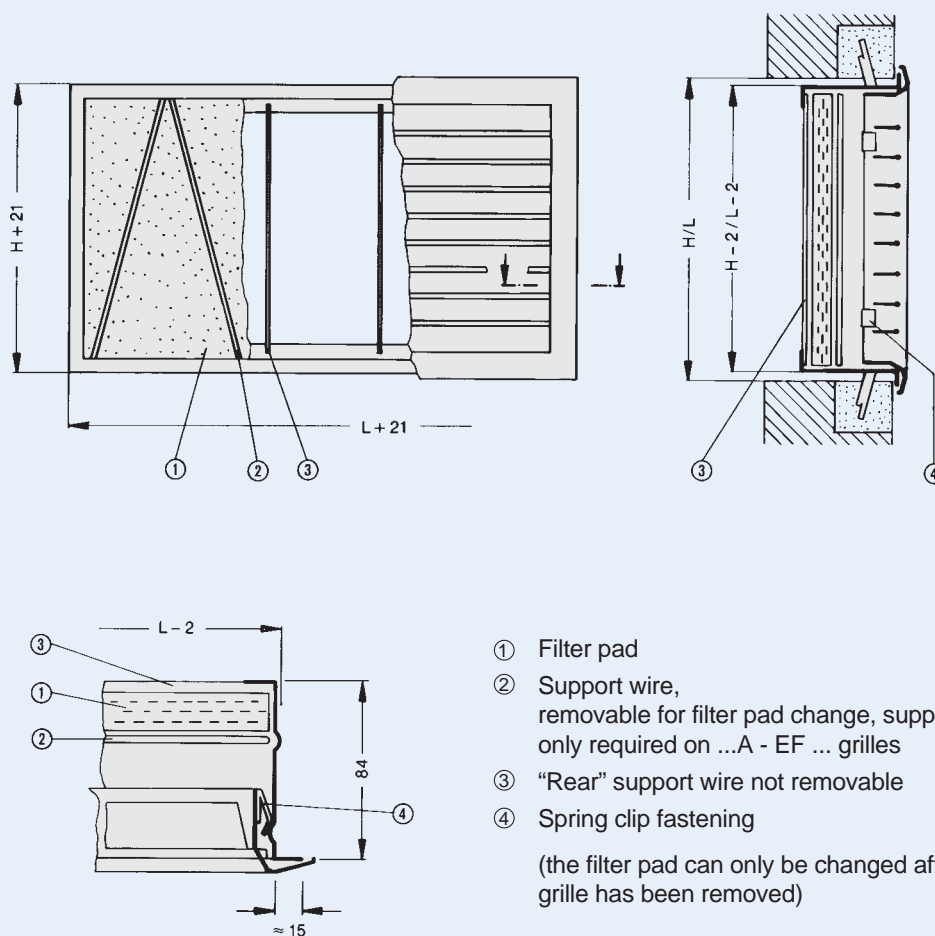

- ① Filter pad
- ② Support wire, removable for filter pad change, support wire only required on ...A - EF ... grilles
- ③ "Rear" support wire not removable
- ④ Spring clip fastening

(the filter pad can only be changed after the grille has been removed)

Grilles and Linear Grille Cores

Dimensions

H	L for Dampers Types AGW · DGW · Z · ASW							
75	225	325	425	525	625	825	1025	1225
125	225	325	425	525	625	825	1025	1225
225	325	425	525	625	825	1025	1225	
325	425	525	625	825	1025	1225		
425	625	825	1025	1225				
525	1025	1225						

Standard Sizes

L x H in mm	Aluminium		Steel			Stainless Steel	Plastic
	ASL	AWT	SL	TR	TRS	TRE	KS
225 x 75 325 425 525 625 825 1025 1225 1425 1625 1825 2025							
225 x 125 325 425 525 625 775 825 1025 1225 1425 1625 1825 2025							
225 x 225 325 * 425 * 525 * 625 * 775 825 * 1025 1225 1425 1625 1825 2025							
325 x 325 425 525 625 775 825 1025 1225 1425 1625 1825 2025							
625 x 425 825 1025 1225							
1025 x 525 1225							

Aluminium Grille Cores

EH · EW	
L _a x H _a in mm	
L _a minimum 130mm maximum 1780mm with intervals of 50mm available	
L _a x 56	L _a x 181
L _a x 81	L _a x 206
L _a x 106	L _a x 231
L _a x 131	L _a x 256
L _a x 156	L _a x 281
	L _a x 306

NOTE: * = not available in TRE-C and TRE-Z

Aluminium Grilles

Dimensions

Standard Sizes²⁾

Finite Grille Type AT . VAT . AGS . AH . WAP			
L x H in mm			
150 x 100 1)	200 x 200	300 x 300	450 x 450
200	250	350	500
250	300	400	550
300	350	450	600
350	400	500	650
400	450	550	700
450	500	600	750
500	550	650	800
550	600	700	850
600	650	750	900
650	700	800	950
700	750	850	1000
750	800	900	1060
800	850	950	1100
850	900	1000	1150
900	950	1050	1200
950	1000	1100	1250
1000	1050	1150	500 x 500
1050	1100	1200	550
1100	1150	1250	600
1150	1200	350 x 350	650
1200	1250	400	700
1250	250 x 250	450	750
150 x 150	300	500	800
200	350	550	850
250	400	600	900
300	450	650	950
350	500	700	1000
400	550	750	1050
450	600	800	1100
500	650	850	1150
550	700	900	1200
600	750	950	1250
650	800	1000	600 x 600
700	850	1150	650
750	900	1200	700
800	950	1250	750
850	1000	400 x 400	800
900	1050	450	850
950	1100	500	900
1000	1150	550	1000
1050	1200	600	1050
1100	1250	650	1100
1150		700	1150
1200		750	1200
1250		800	1250
		850	
		900	
		950	
		1000	
		1050	
		1100	
		1150	
		1200	
		1250	

1) Grille Types AH-0/15-A and WAP-0/15A also available with H=75mm
 2) Minimum height H=100mm when fitted with AG/D/DG rear assemblies.

Standard Sizes²⁾

Finite Grille Type AF		
L x H in mm		
150 x 100 1)	200 x 200	300 x 300
200	250	350
250	300	400
300	350	450
350	400	500
400	450	550
450	500	600
500	550	650
550	600	700
600	650	750
650	700	800
700	750	850
750	800	900
800	850	950
850	900	1000
900	950	1050
950	1000	1100
1000	1050	1150
1050	1100	1200
1100	1150	1250
1150	1200	
1200	1250	
1250	250 x 150	
150 x 150	300	
200	350	
250	400	
300	450	
350	500	
400	550	
450	600	
500	650	
550	700	
600	750	
650	800	
700	850	
750	900	
800	950	
850	1000	
900	1050	
950	1100	
1000	1150	
1050	1200	
1100	1250	
1150		
1200		
1250		

1) AF-0/15-A also available with H=75mm
 2) Minimum height H=100mm when fitted with AG/D/DG rear assemblies.

Aluminium Linear Grilles

Construction · Dimensions · Materials

Construction

Type AH

Supply or return air linear grille with fixed horizontal profiled blades. Front border 30mm wide, blades with either 0° or 15° deflection, Types AH-0 and AH-15 respectively. Available on request with concealed fixing, also on request 20mm front border. Standard finish: Powder coated RAL 9010 20% gloss.

Type WAP

Supply or return air linear grille with fixed horizontal profiled blades. As type AH but 3mm blades on 12.5mm pitch. Standard finish: Powder coated RAL 9010 20% gloss.

Type AF

Supply or return air linear grille for floor or wall mounting with fixed horizontal profiled blades, blades either 0° or 15° deflection. Types AF-0-.. and AF-15-.. respectively. The grille core can be removed by releasing the W clips. Standard finish: Powder coated RAL 9006 25% gloss.

Upto 1800mm 1 section
 1800 up to 3600mm 2 sections
 above 3600mm Made up in a number of 1800mm intermediate lengths plus 2 equal end sections.

Max intermediate length 1800mm sections
 Types AHR . WAPR as type AH . WAP but with 20mm wide border in lieu of 30mm wide border.

Materials

Linear Grilles are made from extruded aluminium section.

Standard Heights¹⁾

H	75	100	125	150	175	200	225	250	275	300
Type										
AH	•	•	•	•	•	•	•	•	•	•
WAP	•	•	•	•	•	•	•	•	•	•
AF										

1) Minimum height H=100mm when fitted with AG/D/DG rear assemblies

Type AH

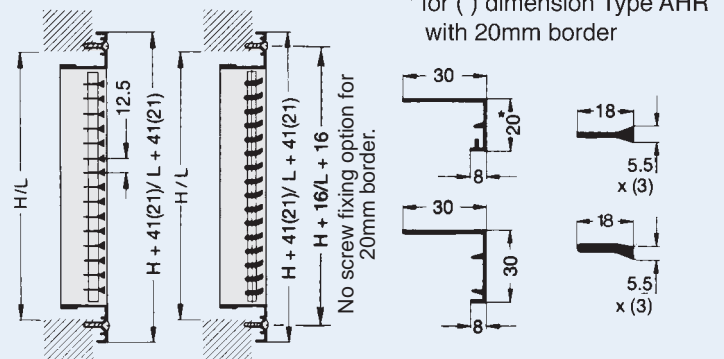
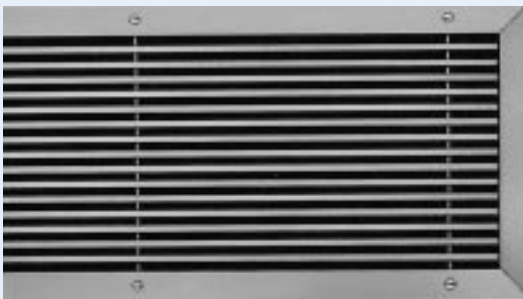

AH-0 AH-15
 WAP-0 WAP-15

0 / 0 Fixing Shown

Type AF

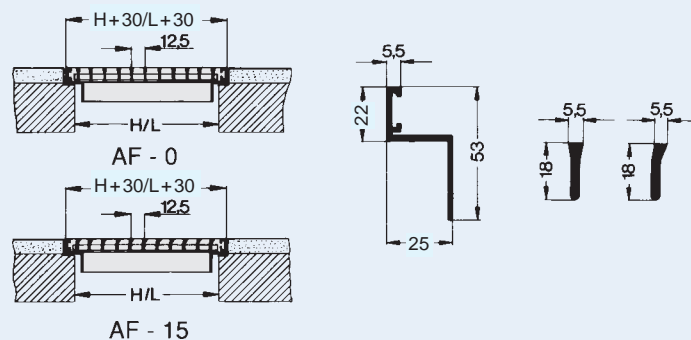

Steel Linear Grilles

Construction · Dimensions · Materials

Type	SL
H	
125	•
225	•
325	•

Intermediate Section M in mm	End Section E in mm
2000	950
	1010
	1070
	1130
	1190
	1250
	1310
	1370
	1430
	1490
	1550
	1610
	1670
	1730
	1790
	1850
1910	
1970	

Number of end and intermediate sections based on the opening size 'L'

Construction

Type SL

Supply or return air linear grille. The front border has a diffuser-type section (L side 28mm wide, H side 20mm wide) with individually adjustable horizontal front blades and a concealed fixing.

Materials

The grille face is made from formed sheet steel. The surface is pre-treated and powder coated (RAL 9010 50% gloss).

Type SL

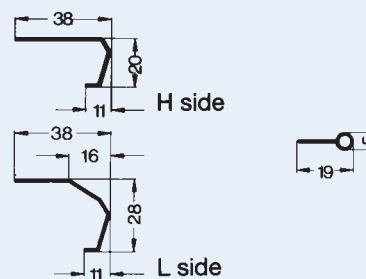
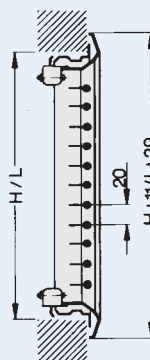

M1 / 0 Fixing Shown

Selection Tables for Linear Grille Lengths

Type · SL (Steel Grille)

Example

Data Given:

Type SL

L = 18910 mm

Select the next size down

L = 18888 mm (opening size plastered surface)

Number of intermediate and end sections :

8 intermediate sections M = 2000 mm

2 end sections E = 1430 mm

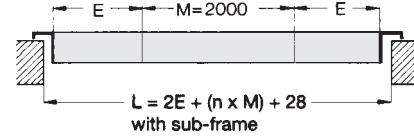

L = inside dimensions of opening

n = number of M sections

The opening size "L" and associated number of end sections "E" and intermediate sections "M" can be directly determined from the selection table below.

E	E	L = 2E + 28	L = 2E + (n x M) + 28									
			1 x M	2 x M	3 x M	4 x M	5 x M	6 x M	7 x M	8 x M	9 x M	10 x M
			2000	4000	6000	8000	10000	12000	14000	16000	18000	20000
950	950	1928	3928	5928	7928	9928	11928	13928	15928	17928	19928	21928
950	1010	1988	3988	5988	7988	9988	11988	13988	15988	17988	19988	21988
1010	1010	2048	4048	6048	8048	10048	12048	14048	16048	18048	20048	22048
1010	1070	2108	4108	6108	8108	10108	12108	14108	16108	18108	20108	22108
1070	1070	2168	4168	6168	8168	10168	12168	14168	16168	18168	20168	22168
1070	1130	2228	4228	6228	8228	10228	12228	14228	16228	18228	20228	22228
1130	1130	2288	4288	6288	8288	10288	12288	14288	16288	18288	20288	22288
1130	1190	2348	4348	6348	8348	10348	12348	14348	16348	18348	20348	22348
1190	1190	2408	4408	6408	8408	10408	12408	14408	16408	18408	20408	22408
1190	1250	2468	4468	6468	8468	10468	12468	14468	16468	18468	20468	22468
1250	1250	2528	4528	6528	8528	10528	12528	14528	16528	18528	20528	22528
1250	1310	2588	4588	6588	8588	10588	12588	14588	16588	18588	20588	22588
1310	1310	2648	4648	6648	8648	10648	12648	14648	16648	18648	20648	22648
1310	1370	2708	4708	6708	8708	10708	12708	14708	16708	18708	20708	22708
1370	1370	2768	4768	6768	8768	10768	12768	14768	16768	18768	20768	22768
1370	1430	2828	4828	6828	8828	10828	12828	14828	16828	18828	20828	22828
1430	1430	2888	4888	6888	8888	10888	12888	14888	16888	18888	20888	22888
1430	1490	2948	4948	6948	8948	10948	12948	14948	16948	18948	20948	22948
1490	1490	3008	5008	7008	9008	11008	13008	15008	17008	19008	21008	23008
1490	1550	3068	5068	7068	9068	11068	13068	15068	17068	19068	21068	23068
1550	1550	3128	5128	7128	9128	11128	13128	15128	17128	19128	21128	23128
1550	1610	3188	5188	7188	9188	11188	13188	15188	17188	19188	21188	23188
1610	1610	3248	5248	7248	9248	11248	13248	15248	17248	19248	21248	23248
1610	1670	3308	5308	7308	9308	11308	13308	15308	17308	19308	21308	23308
1670	1670	3368	5368	7368	9368	11368	13368	15368	17368	19368	21368	23368
1670	1730	3428	5428	7428	9428	11428	13428	15428	17428	19428	21428	23428
1730	1730	3488	5488	7488	9488	11488	13488	15488	17488	19488	21488	23488
1730	1790	3548	5548	7548	9548	11548	13548	15548	17548	19548	21548	23548
1790	1790	3608	5608	7608	9608	11608	13608	15608	17608	19608	21608	23608
1790	1850	3668	5668	7668	9668	11668	13668	15668	17668	19668	21668	23668
1850	1850	3728	5728	7728	9728	11728	13728	15728	17728	19728	21728	23728
1850	1910	3788	5788	7788	9788	11788	13788	15788	17788	19788	21788	23788
1910	1910	3848	5848	7848	9848	11848	13848	15848	17848	19848	21848	23848
1910	1970	3908	5908	7908	9908	11908	13908	15908	17908	19908	21908	23908
1970	1970	3968	5968	7968	9968	11968	13968	15968	17968	19968	21968	23968

Rear Assemblies

The rear assemblies are factory fitted to the various types of grille face. The possible combinations - grille plus rear assemblies - are shown in the table on page 16.

Materials

The rear assemblies are made from formed sheet steel. The surface is stove enamelled black RAL 9005.

Materials for Type TRE

The rear assemblies are made from formed stainless steel (DIN ref : 1.4301 or higher). The material has a dull pickled surface.

Rear Assemblies	Installation depth dimensions T					
	ASL · SL · TR · TRS	TRE	AWT	AF	AT · VAT	AH · WAP
... - AG	108	105	123	123	107	105
... - D	70	67	85	81	61	59
... - AS	80	-	-	-	-	-
... - Z	70 ... 238	65 ... 235	80 ... 250	-	-	-
... - DG	108	105	123	123	107	105
... - DL	72	-	-	-	-	-
... - AL	40	-	-	-	-	-
... - C	70 ... 238	65 ... 235	-	-	-	-

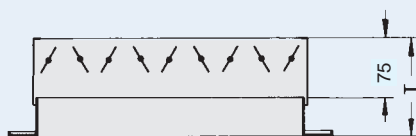

...-AG

Opposed blade action volume control damper, adjustable from the front face.

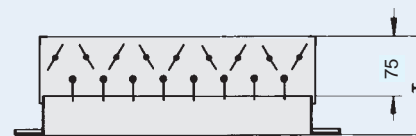

...-DG

Volume control damper as ...-AG plus a set of individually adjustable vertical air pattern control blades. For types VAT and TRS these blades are horizontal (Type TR with stamped pattern blades).

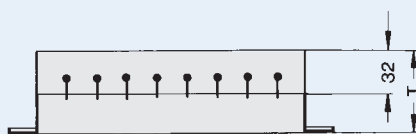

...-D

A set of individually adjustable vertical air pattern control blades. For types VAT and TRS, these blades are horizontal (type TR with stamped pattern blades).

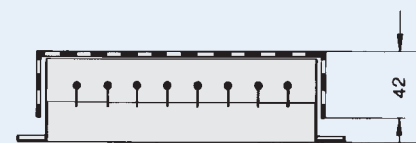

...-DL

Rear deflection blades, as ...-D, also with perforated plate baffle, as ...-AL.

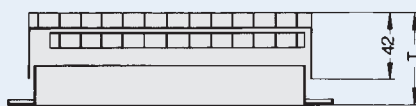

...-AS

Volume control of hit and miss construction with stamped vertical blades, adjustable from the front face, ($H_{max} = 325mm$).



...-AL

Perforated plate baffle with 35% free cross section.

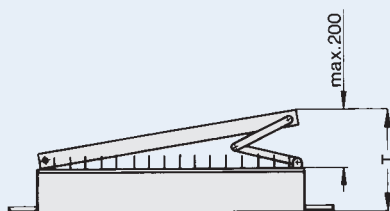

...-Z

Flap type volume control with stamped pattern air straightening blades, adjustable from the front face.

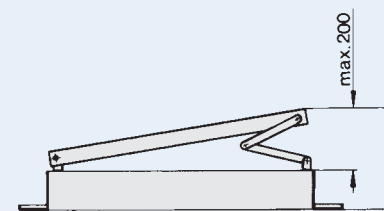

...-C

Volume controller of flap construction which can be adjusted from the front face.

Rear Assemblies

Grilles · Linear Grilles

Type	Grilles										Linear Grilles					
	ASL	AT	VAT	AH-0/AH-15 WAP-0 WAP-15	AF-0 / AF-15	AWT	AGS	SL	TR	TRS	TRE	KS	AH-0/AH-15 WAP-0 WAP-15	AF-0/AF-15	SL	
Standard Construction -A	■	■	■	■	■	■	See Page 5 for construction	■	■	■	■	■	■	■	■	
Rear Assemblies	-AG 1)	■	■	■	■	■		■	■	■	■	■	■	■	■	■
	-D	■	■	■	■	■		■	■	■	■	■	■	■	■	■
	-DG 1)	■	■	■	■	■		■	■	■	■	■	■	■	■	■
	-Z 2)	■						■				■				
	-AL									■	■					
	-DL									■	■					
	-AS 3)									■	■					
-C									■	■	■	■	■	■	■	
Special Standard Construction -A-EF								■	■	■						
Filter Frame With Rear Assembly -AS-FF							■	■	■							

1) For duct installation with angle frame type (AGW, DGW) supplied loose (see page 7).

2) For duct installation (L_{max} - 1225) supplied loose.

3) Not available with concealed fixing.

4) Rear assemblies integral with the grille face section.

5) Sizes 625 x 325 and 775 x 325 not available.

Component Adjustment

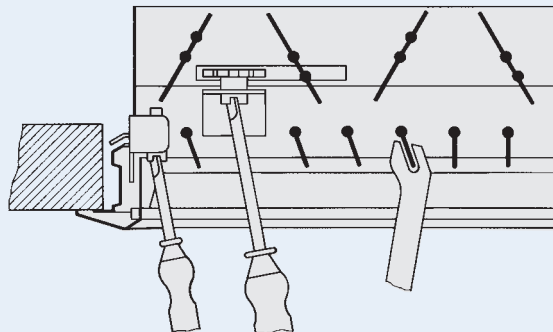

Rear Assemblies ...-D, ...-AG, ...-DG
concealed fixing

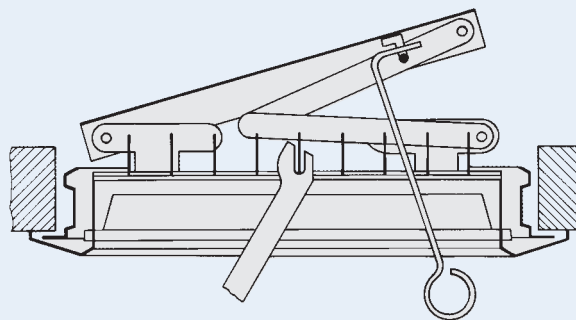

Rear Assemblies ...-Z, ...-D, ...-DG, ...-C

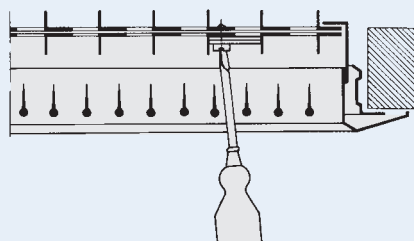

Rear Assemblies ...-AS

Fixing Details

Type AGS

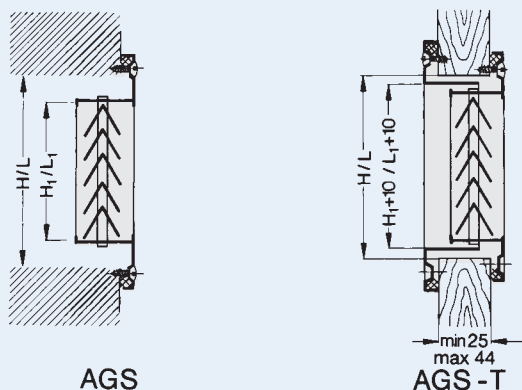

For all constructions : $H_1 = H - 19$
 $L_1 = L - 19$

Type AF

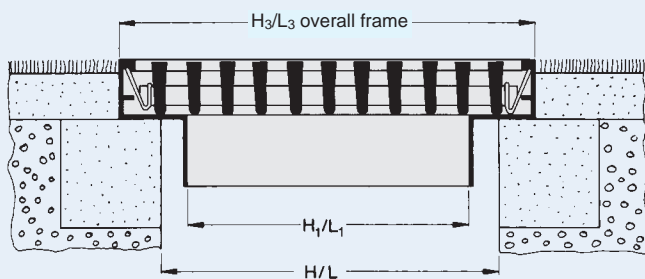

$H_1 = H - 20$ $H_3 = H + 30$
 $L_1 = L - 20$ $L_3 = L + 30$

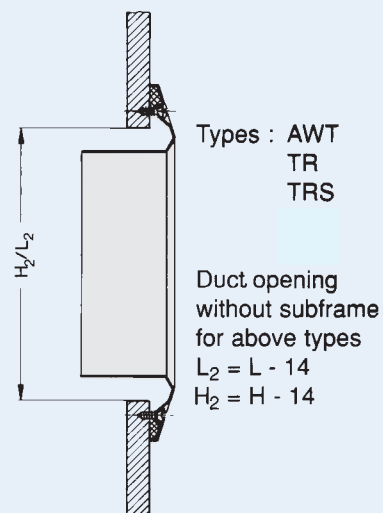

Types : AWT
 TR
 TRS

Duct opening
 without subframe
 for above types
 $L_2 = L - 14$
 $H_2 = H - 14$

0 / 0 Fixing Shown

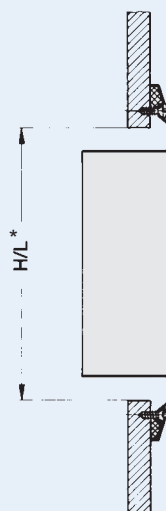

Types : AT
 VAT
 AH
 WAP
 AGS

*Duct opening size
 for above types with
 screw fix H/L.
 For concealed fixing
 opening size is $H+6/L+6$.

0 / 0 Fixing Shown

Installation Details

Installation Details for 'Finite' Grilles with Trox concealed Fastener Type AT VAT AH WAP

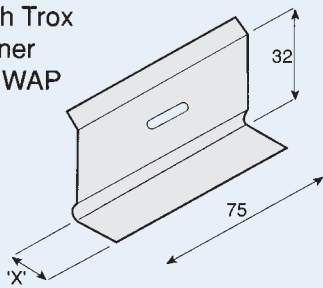

Type B30 - 30mm border : x = 15
 Type B20 - 20mm border : x = 5

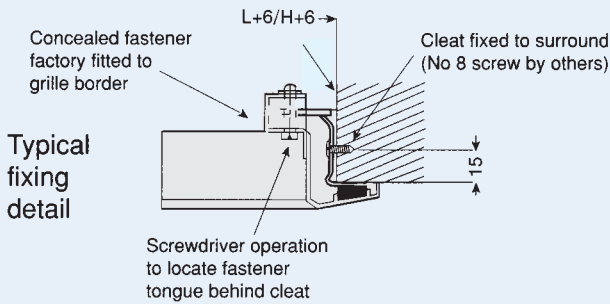

Fixing cleat locations: in opening surround (Typical) Actual Grille used to ensure correct location.

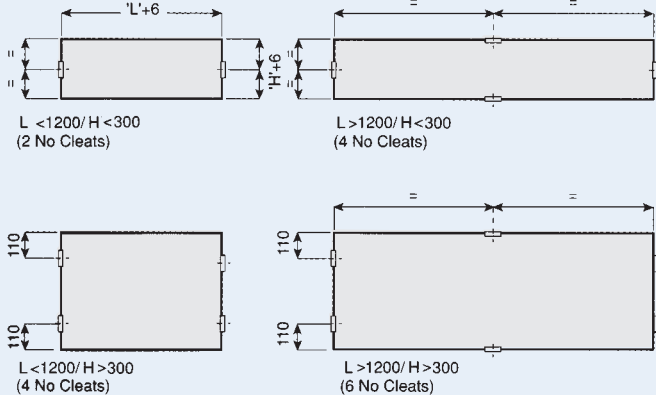

Installation Details for Linear Grilles with Trox concealed Fastener Type AH WAP

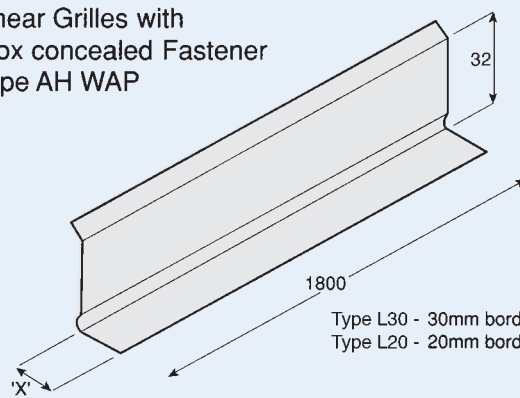

Type L30 - 30mm border : x = 15
 Type L20 - 20mm border : x = 5

Support frame locations in opening surround

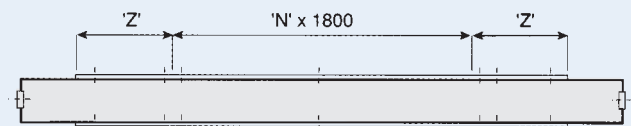

Quantity for Linear Grille of length L mm:
 for 'L' < 3600 = 4 No (1800mm section)
 for 'L' > 3600 = (N+4) where 'N' = No of 1800 long centre sections of grille
 Site cut length 'Z' approx 900 long to suit fastener locations
 end brackets cut from remainder

Installation Subframe (ASL · SL Only)

Installation subframes supplied with steel grilles and ASL, aluminium grilles are delivered as individual components, tied together with different banding and must be assembled into a complete subframe on site by others, using the tongue and spigot connections.

- Red Banding : Type SL
- White Banding : All other steel types plus type ASL

Materials

The installation subframes are made from formed, galvanised sheet steel.

Installation Subframe for Grilles (ASL & SL)

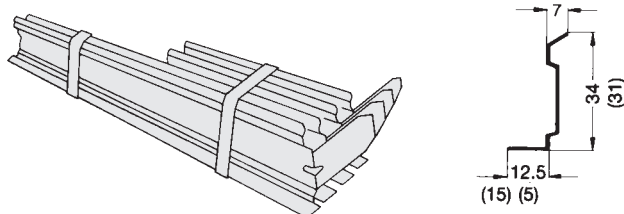

() dimensions applicable for SL/H side.

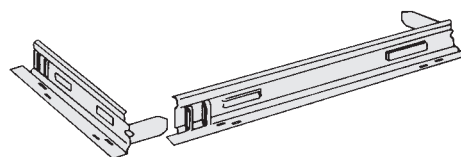

Tongue and Spigot Connection

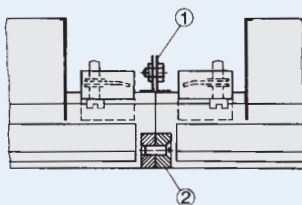

Type SL

- ① Bolt connection of installation subframes
- ② Screw connection for the grille face sections

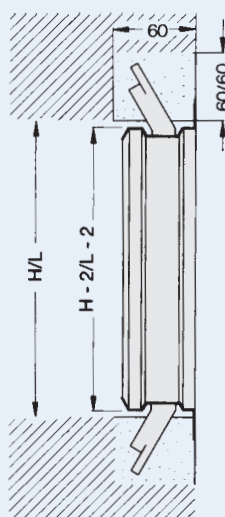

Wall installation with Builders Work Cleats

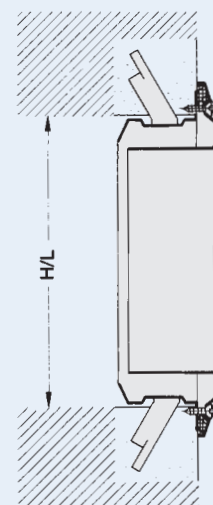

Subframe with screw fixing

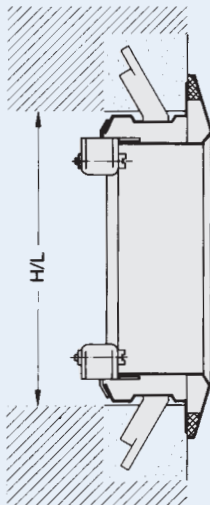

With concealed fixing

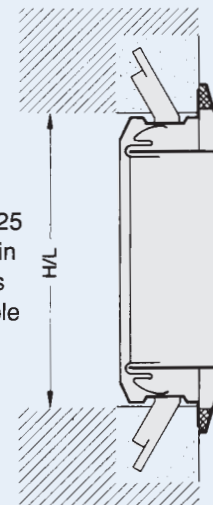

With spring clip fixing (ASL only)

$L_{max} = 1225$
Mounting in a ceiling is not possible

All counter punched holes suitable for sheet metal raised countersunk head screws 4.2 x 16

Installation Subframe for Steel Grille (SL)

Installation subframes for Linear Grilles (SL) (for frame section see page 19)

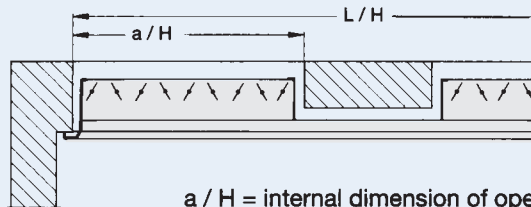
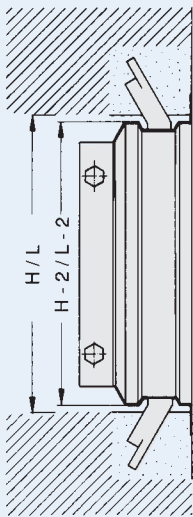

a / H = internal dimension of opening

When a linear grille is required with non-active sections, the rear sections are supplied loose for site assembly to meet the local requirements.

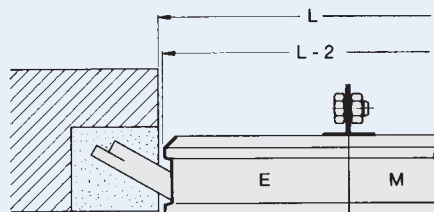

When fitting the subframes, great care should be taken in order to avoid distortion.

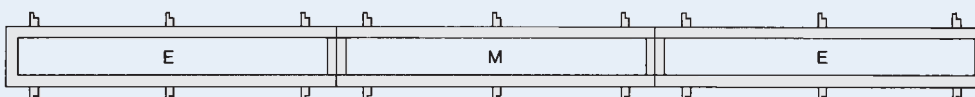

"E" and "M" sections corresponding to the face grille lengths.

Nomenclature · Acoustic Data

Grilles · Linear Grilles

Nomenclature

\dot{V} in l/s m : Volume flow per metre
 \dot{V} in m³/h m : Volume flow per metre
 \dot{V}_t in l/s : Total volume flow
 \dot{V}_t in m³/h : Total volume flow
 L in m : Distance from the grille or linear grille (throw)
 B in m : Spacing between two grilles
 v_{geo} in m/s : Air velocity based on geometric free area
 v_k in m/s : Air velocity in the duct
 \bar{v}_L in m/s : Time average air velocity at distance L
 $b_{0.2}$ in m : Distance from the centre of the airstream at which the velocity is a maximum of 0.2 m/s
 y in m : Airstream drop or rise
 i Induction ratio : $\frac{\text{Total airstream volume flow}}{\text{Volume flow at grille discharge}}$
 v_{eff} in m/s : Effective jet velocity
 A_{eff} in m² : Effective outlet area
 A_{geo} in m² : Geometric free area
 h_{eff} in m : Effective outlet height ($A_{eff} = h_{eff} \times L_1/1000$)
 α in ° : Airstream discharge angle

β in ° : Blade angle in the case of divergent setting
 Δt_z in K : Temperature difference between supply and room air
 Δt_L in K : Difference between core and room temperature at distance L
 L_1 in mm : Grille core size (length)
 H_1 in mm : Grille core size (height)
 Δp_t in Pa : Total pressure drop
 L_{WA} in dB(A) : A - weighted sound power level, based on $A_{eff} = 0.1\text{m}^2$ (see table for corrections)
 L_{WNC} NC rating of sound power level
 L_{W} in dB/Oct : Octave sound power level of regenerated noise based on $A_{eff} = 0.1\text{m}^2$ (see table for corrections)
 L_{pA}, L_{pNC} A - weighting and NC rating respectively of room sound pressure level
 $L_{pA} \approx L_{WA} - 8\text{dB}$
 $L_{pNC} \approx L_{WNC} - 8\text{dB}$

For grille where $L \div H > 12$ to 1, selection must be made using the technical data for linear grilles.

1 Sound power level & Pressure drop with flap damper ...-Z

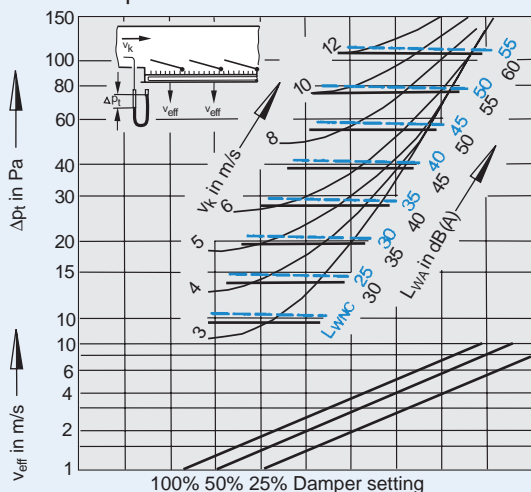

Correction values for A_{eff}

A _{eff} in m ²	0,005	0,01	0,02	0,05	0,1	0,2	0,4
L _{WA} / L _{WNC}	-13	-10	-7	-3	-	+3	+6

Diagram values based on $A_{eff} + 0.1\text{m}^2$
(zero blade divergence)

Correction values for h_{eff}

h _{eff} in m	Linear grilles length L ₁ in mm			
	2000	4000	4000	4000
0,030	-2	-1	-	+ 1
0,050	-	+1	+2	+ 3
0,075	+1	+2	+3	+ 4
0,100	+3	+4	+5	+ 6
0,150	+5	+6	+7	+ 8
0,200	+6	+7	+8	+ 9
0,250	+7	+8	+9	+10

Diagram values based on $h_{eff} + 0.1\text{m}^2$
(zero blade divergence)

2 Octave band sound power levels with flap damper ...-Z

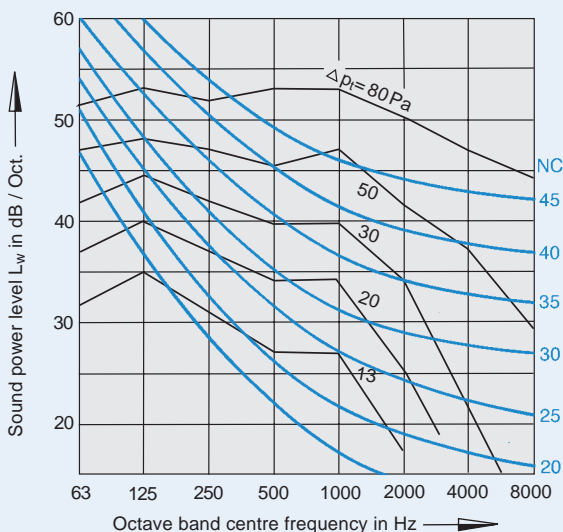

Correction values for other blade setting

Grille Face	0°	45°	90°	45°	90°
Pattern Control Blades	0°	0°	0°	45°	90°
Δp_t	x 1,0	x 1,1	x 1,2	x 1,1	x 1,5
L _{WA} / L _{WNC}	-	+1	+3	+1	+6

- Grilles can have horizontal / vertical divergence
 - Linear grilles can only have vertical divergence

Acoustic Data for Supply Air

Grilles · Linear Grilles

On diagram 3 :

Diagram values for the 25% damper setting are also valid for rear assemblies AL and DL.
 Diagram values for the 100% damper setting are also valid for no opposed blade damper.

3 Sound power level and Pressure drop with opposed blade damper ...-AG & ...-DG
 Damper setting 25% open 50% open

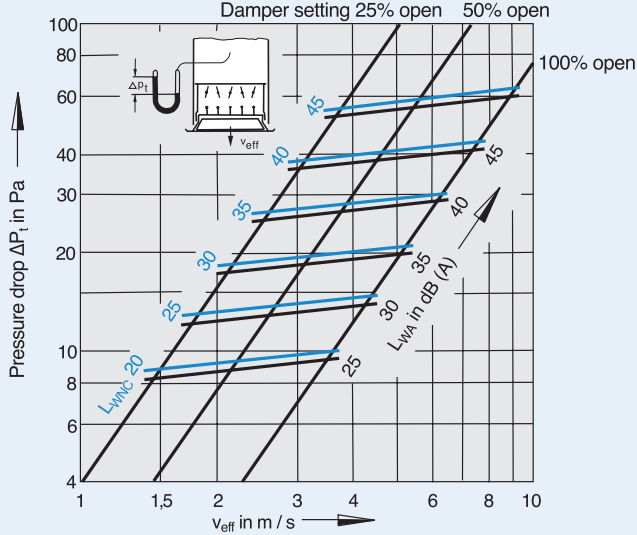

5 Octave band sound power levels with opposed blade damper ...-AG & ...-DG
 Damper setting 50% open

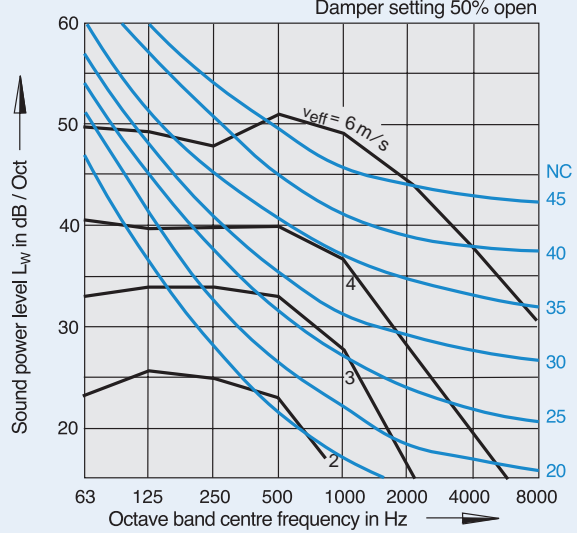

4 Octave band sound power levels with opposed blade damper ...-AG & ...-DG
 Damper setting 100% open

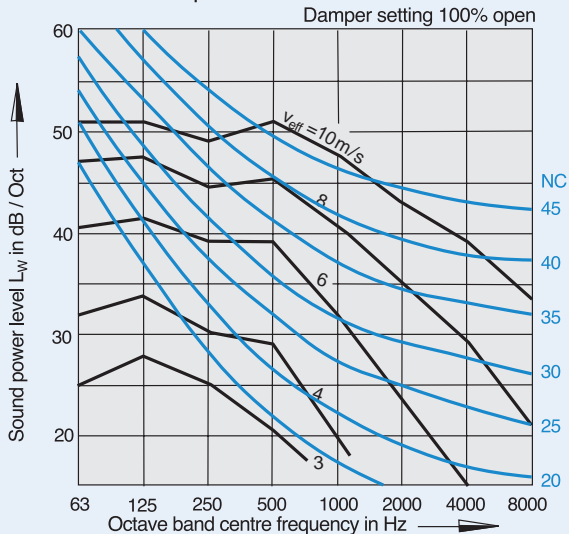

6 Octave band sound power levels with opposed blade damper ...-AG & ...-DG
 Damper setting 25% open

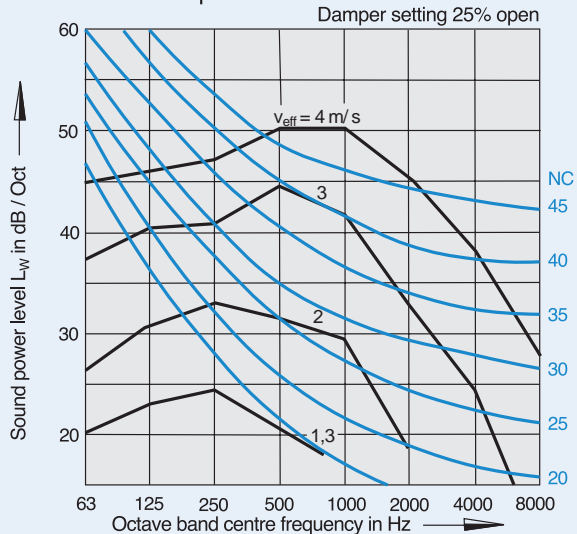

Acoustic Data for Return Air

On diagram 7 :

Diagram values for the 100% damper setting are also valid for no opposed blade damper.

Correction values for A_{eff}

A_{eff} in m^2	0,005	0,01	0,02	0,05	0,1	0,2	0,4
L_{WA} / L_{WNC}	- 13	- 10	- 7	- 3	-	+ 3	+6

Diagram values based on $A_{eff} = 0.1m^2$
(zero blade divergence)

7 Sound power and Pressure drop for opposed blade damper ...-AG

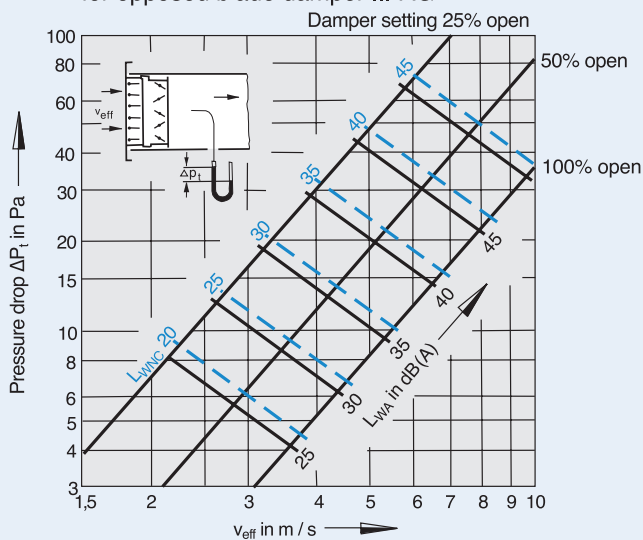

9 Octave band sound power levels with opposed blade damper ...-AG

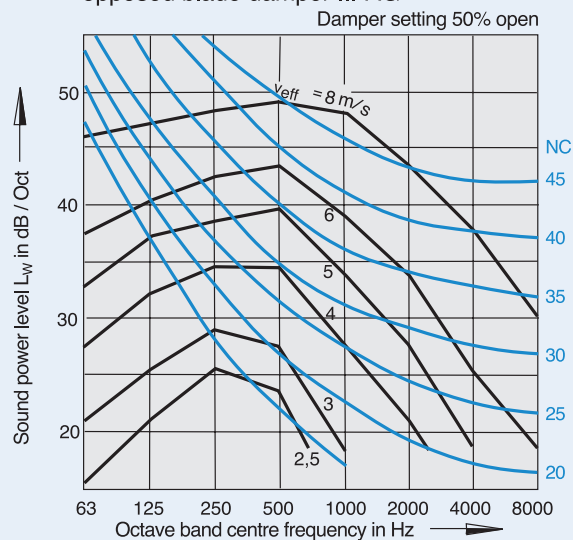

8 Octave band sound power levels with opposed blade damper ...-AG

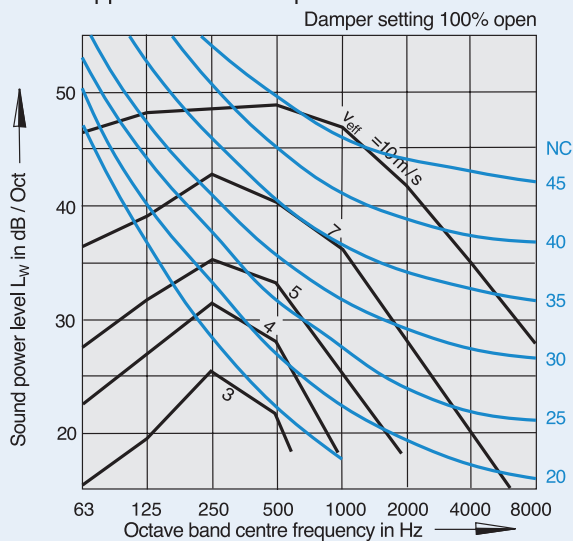

10 Octave band sound power levels with opposed blade damper ...-AG

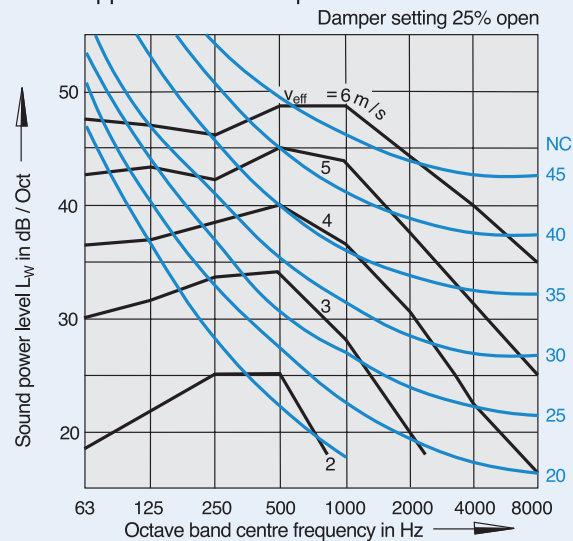

Acoustic Data for Return Air

11 Sound power and Pressure drop with hit and miss damper ...-AS

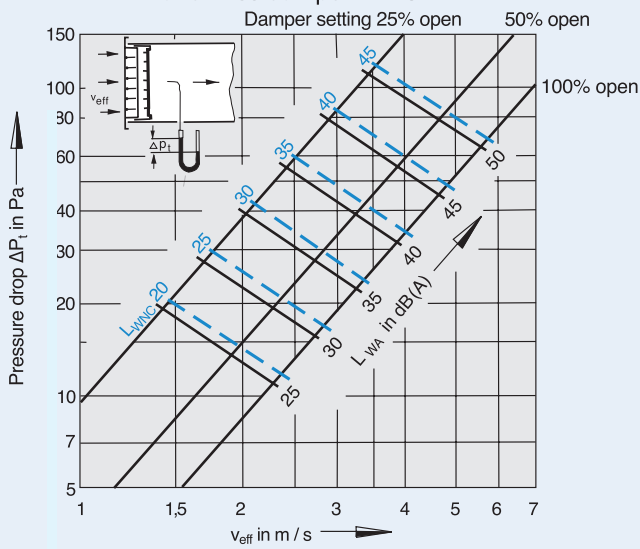

13 Octave band sound power levels with hit and miss damper ...-AS

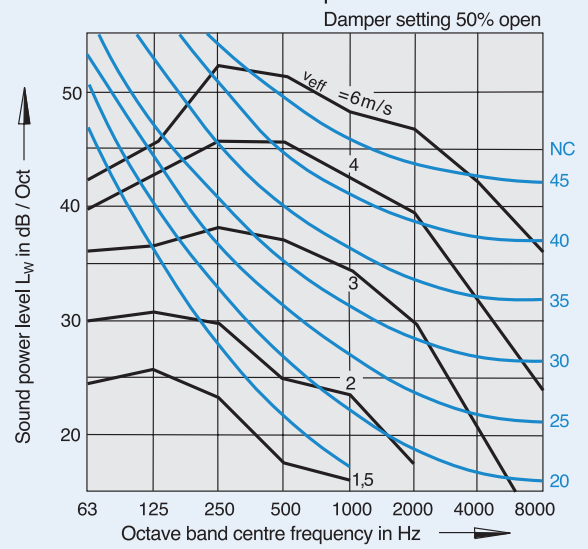

12 Octave band sound power levels with hit and miss damper ...-AS

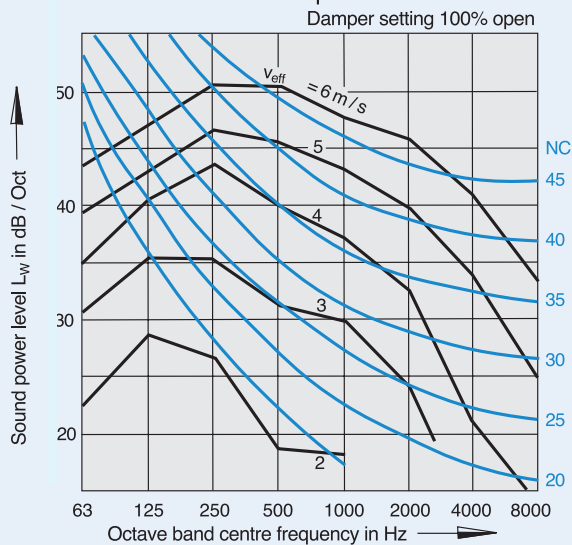

14 Octave band sound power levels with hit and miss damper ...-AS

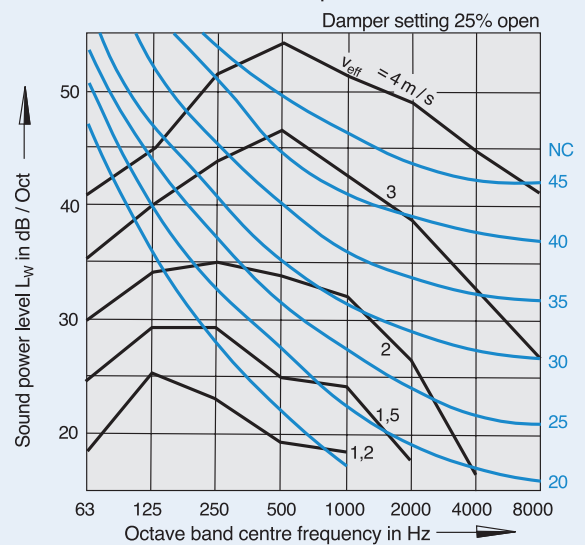

Aerodynamic Data Grilles

Example :

Data Given :

Type AT-A, with ceiling effect

Total volume flow $\dot{V}_t = 155 \text{ l/s}$

Maximum jet velocity at distance L $\bar{v}_L = 0.5 \text{ m/s}$

Distance from the grille $L = 10\text{m}$

Temperature differential $\Delta t_z = 4\text{K}$

Diagram 15 :

$A_{\text{eff}} = 0.041 \text{ m}^2$

$v_{\text{eff}} = 3.8 \text{ m/s}$

$b_{0,2} = 1.2 \text{ m}$

$i = 15$

$\Delta t_L / \Delta t_z = 0.13$

$\Delta t_L = 4 \times 0.13 = 0.52\text{K}$

$B \geq 1.5 \text{ m}$

Table on page 27 :

$A_{\text{eff}} = 0.041 \text{ m}^2$

$A_{\text{eff}} \approx 0.038 - 0.042 \text{ m}^2$

$L \times H = 700 \times 100 \text{ or } 250 \times 250$

Correction factors for installation without ceiling effect
If the distance to the ceiling is $\geq 0.8\text{m}$, the diagram values \bar{v}_L , $b_{0,2}$, $\Delta t_L / \Delta t_z$ should be multiplied by a factor of 0.71.

Installation with ceiling effect.

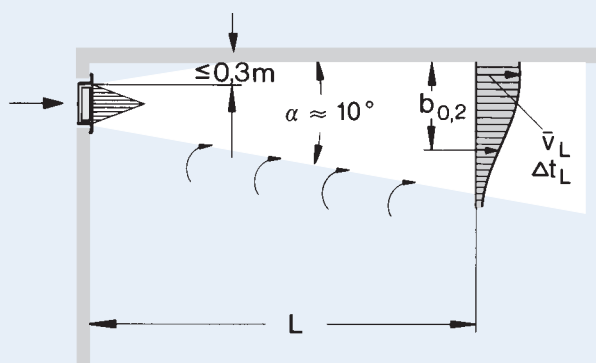

Installation without ceiling effect.

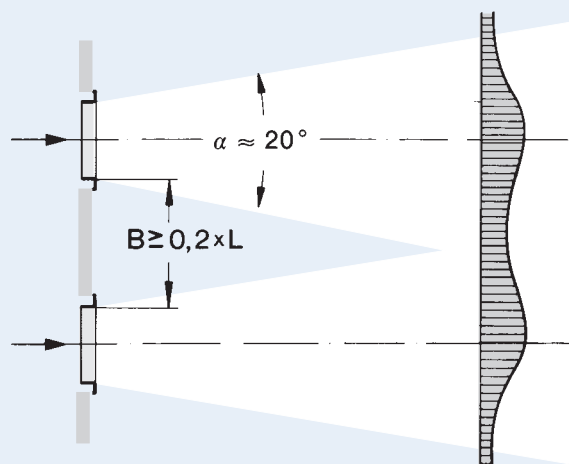
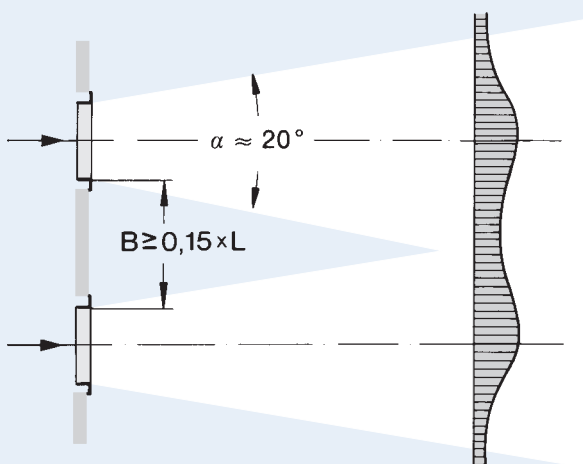
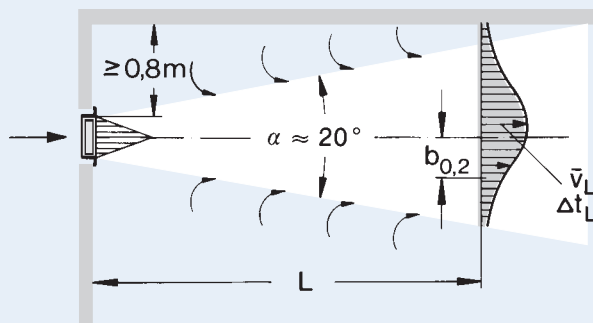

Effective Outlet Area - Aerodynamic Data

Grilles with Ceiling Effect

H in mm	Type	L Length in mm								
		225	325	425	525	625	775	825	1025	1225
75	TRS	0.007	0.011	0.014	0.018	0.021	-	0.029	0.036	0.043
125	ASL TR TRS TRE SL KS	0.014	0.021	0.029	0.036	0.043	0.054	0.057	0.072	0.086
	AWT	0.010	0.015	0.020	0.025	0.031	-	0.040	0.050	0.060
225	ASL TR TRS TRE SL KS	0.029	0.043	0.057	0.072	0.086	0.107	0.114	0.142	0.172
	AWT	-	0.031	0.040	0.050	0.060	-	0.078	0.097	0.116
325	ASL TR TRS TRE SL	-	0.064	0.086	0.108	0.129	0.161	0.172	0.214	0.256
	AWT	-	-	0.060	0.073	0.086	-	0.116	0.152	0.174
425	ASL TR SL	-	-	-	-	0.172	-	0.228	0.285	0.342
525	TR SL	-	-	-	-	-	-	-	0.355	0.427

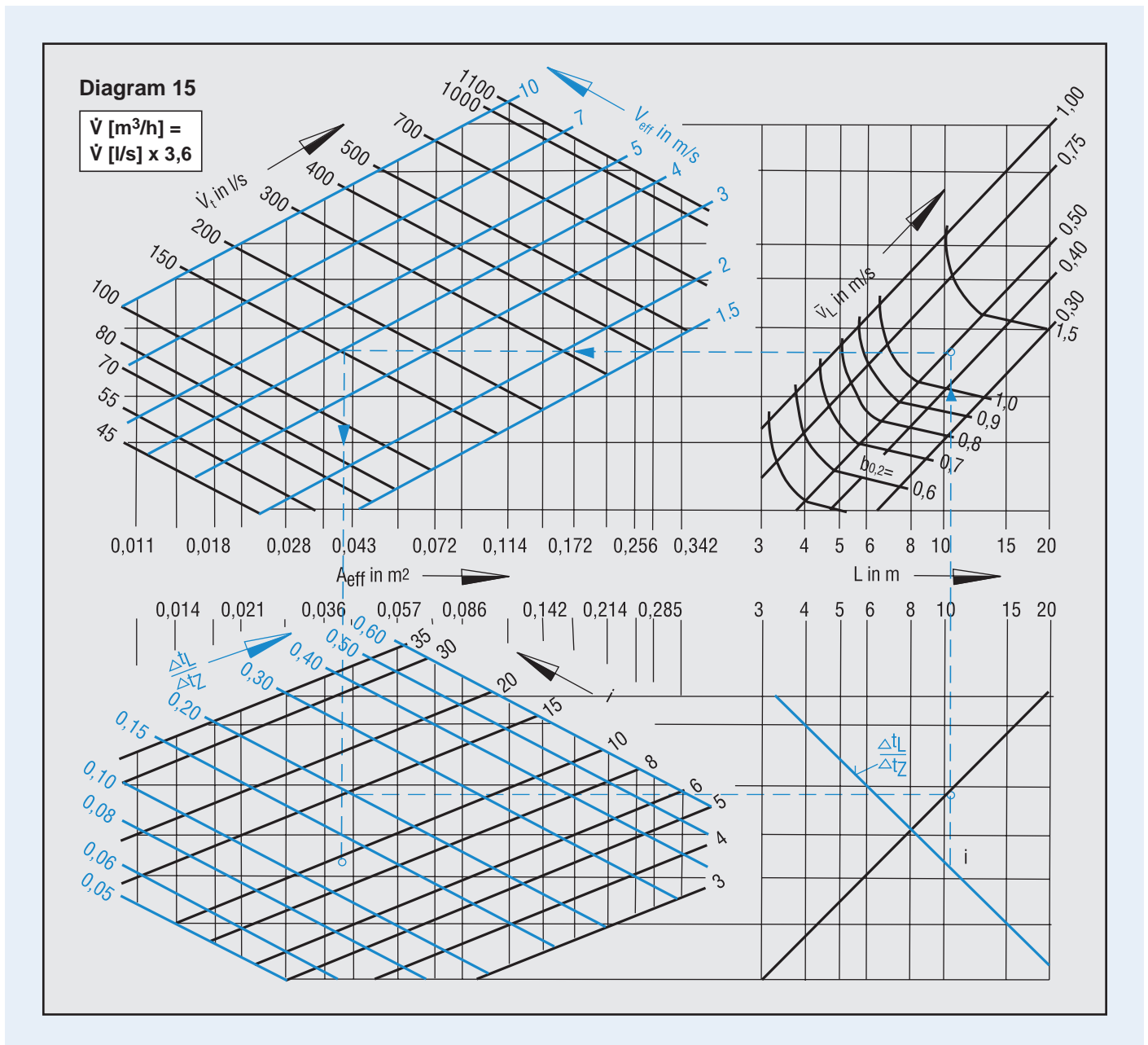

Technical Data · Effective Outlet Area

Supply Air Grilles · Effective Outlet Area Tables A_{eff} (m²)

H in mm	Type	L Length in mm														
		150	200	250	300	350	400	450	500	600	700	800	900	1000	1100	1200
100	AT · VAT	0.008	0.011	0.015	0.018	0.021	0.024	0.027	0.030	0.036	0.042	0.048	0.055	0.060	0.067	0.073
	AH · AF	0.006	0.008	0.010	0.012	0.014	0.017	0.019	0.021	0.026	0.030	0.035	0.039	0.044	0.048	0.053
	WAP	0.009	0.011	0.014	0.016	0.019	0.022	0.025	0.028	0.034	0.040	0.046	0.052	0.058	0.064	0.070
150	AT · VAT	0.013	0.017	0.023	0.027	0.032	0.036	0.041	0.045	0.055	0.064	0.074	0.084	0.092	0.102	0.111
	AH · AF	0.009	0.013	0.016	0.020	0.023	0.027	0.030	0.034	0.041	0.048	0.056	0.063	0.070	0.077	0.084
	WAP	0.012	0.017	0.021	0.026	0.031	0.036	0.041	0.045	0.055	0.064	0.073	0.083	0.092	0.102	0.111
200	AT · VAT	-	0.023	0.030	0.036	0.043	0.049	0.055	0.061	0.074	0.087	0.099	0.112	0.124	0.137	0.150
	AH · AF	-	0.017	0.022	0.027	0.032	0.037	0.042	0.047	0.056	0.066	0.076	0.085	0.095	0.105	0.114
	WAP	-	0.023	0.029	0.036	0.042	0.049	0.055	0.062	0.075	0.089	0.102	0.115	0.128	0.141	0.154
250	AT · VAT	-	-	0.038	0.047	0.055	0.063	0.071	0.079	0.095	0.112	0.129	0.145	0.161	0.178	0.194
	AH · AF	-	-	0.028	0.035	0.041	0.047	0.053	0.059	0.072	0.084	0.096	0.109	0.121	0.133	0.146
	WAP	-	-	0.038	0.047	0.055	0.063	0.071	0.080	0.096	0.113	0.130	0.146	0.163	0.180	0.196
300	AT · VAT	-	-	-	0.056	0.066	0.076	0.085	0.095	0.114	0.134	0.154	0.174	0.193	0.213	0.233
	AH · AF	-	-	-	0.042	0.049	0.057	0.064	0.072	0.087	0.102	0.117	0.132	0.147	0.162	0.177
	WAP	-	-	-	0.057	0.067	0.077	0.087	0.097	0.117	0.138	0.158	0.178	0.198	0.219	0.239
350	AT · VAT	-	-	-	-	0.077	0.088	0.099	0.110	0.133	0.157	0.180	0.203	0.225	0.248	0.271
400	AT · VAT	-	-	-	-	-	0.103	0.116	0.128	0.155	0.182	0.209	0.236	0.262	0.289	0.316
450	AT · VAT	-	-	-	-	-	-	0.131	0.144	0.174	0.204	0.235	0.265	0.293	0.324	0.354
500	AT · VAT	-	-	-	-	-	-	-	0.160	0.193	0.227	0.260	0.294	0.325	0.359	0.393
600	AT · VAT	-	-	-	-	-	-	-	-	0.234	0.275	0.315	0.356	0.394	0.435	0.476

Aerodynamic Data

Grilles

Determination of Volume Flow :

The volume flow can be determined by measuring the air velocity with zero blade divergence using either a pitot tube or a rotating vane anemometer.

Pitot Tube (figure 1) :

Measurements of air velocity should be made between the blades at a number of positions to determine an arithmetic mean value $v_{\text{eff mean}}$.

The volume flow is then calculated as follows :

$$\dot{V}_t \text{ (l/s)} = v_{\text{eff mean}} \text{ (m/s)} \times A_{\text{eff}} \text{ (m}^2\text{)} \times 1000$$

Rotating Vane Anemometer (figure 2) :

The measurement instrument should be evenly transversed across the entire grille face to determine a value of v_{mean}

The volume flow is then calculated as follows:

$$\dot{V}_t \text{ (l/s)} = v_{\text{mean}} \text{ (m/s)} \times A_{\text{eff}} \text{ (m}^2\text{)} \times 1.33 \times 1000$$

Volume Flow Measurement

Figure 1

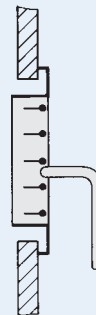
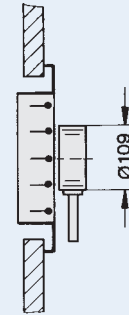
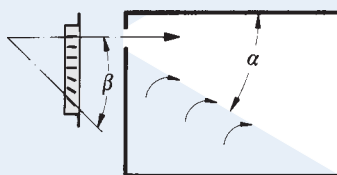

Figure 2



Correction Factors (where L - const.)

with ceiling effect :



without ceiling effect :

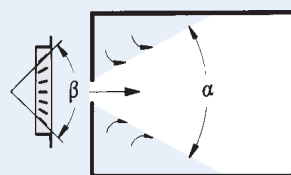

Aerodynamic Data Grilles

Correction for diagrams 16 & 17 (for setting of blade divergence)

β	45°	90°
α	35°	60°
\bar{v}_L	x 0,7	x 0,5
$\Delta t_L / \Delta t_z$	x 0,7	x 0,5
i	x 1,4	x 2,0
γ	x 1,4	x 2,0
with ceiling effect $B \geq$	L x 0,2	L x 0,3
without ceiling effect $B \geq$	L x 0,25	L x 0,3

16 Without ceiling effect
Airstream drop or rise y due to temperature difference

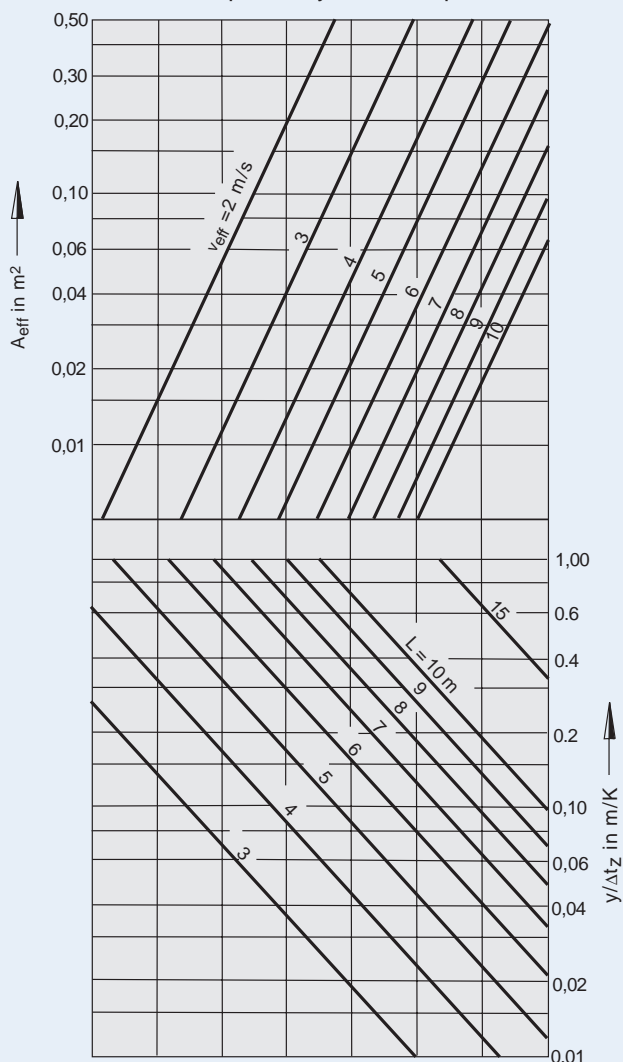

17 With ceiling effect
Maximum temperature difference Δt_z in cooling mode

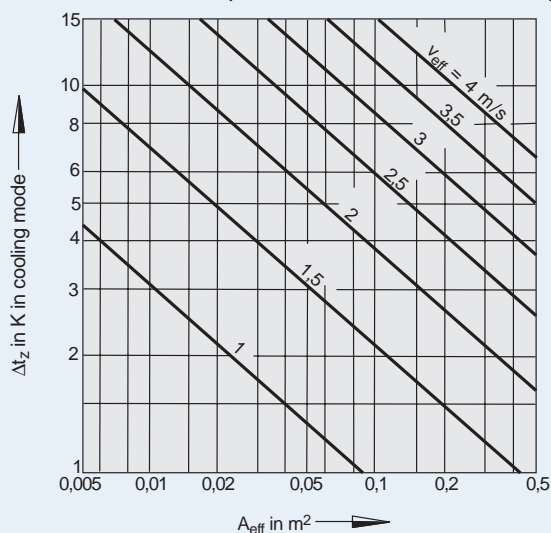

On diagram 17 :
To prevent the airstream dropping into the occupied zone, reference should be made to the graph above, This shows the maximum cooling differential which may be used related to the effective outlet area and effective outlet velocity.

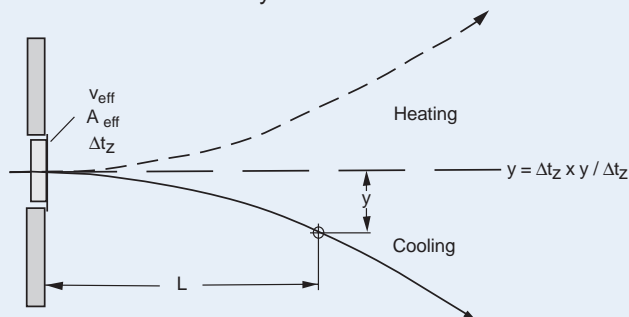

Aerodynamic Data

Linear Grilles

Correction factors for installation without ceiling effect. If the distance to the ceiling is $\geq 0.8\text{m}$, the diagram values v_L , $b_{0,2}$, $\Delta t_L/\Delta t_z$ should be multiplied by a factor of 0.71.

Installation with ceiling effect :

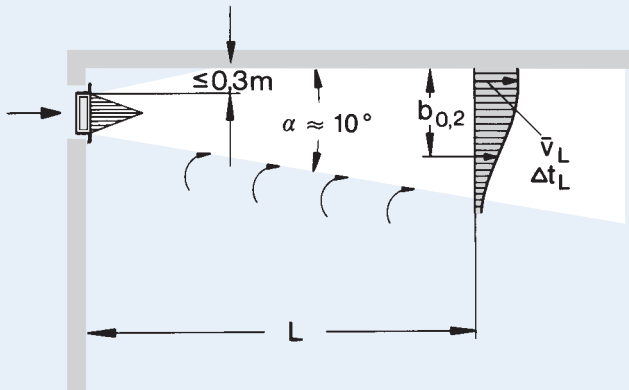

Installation without ceiling effect :

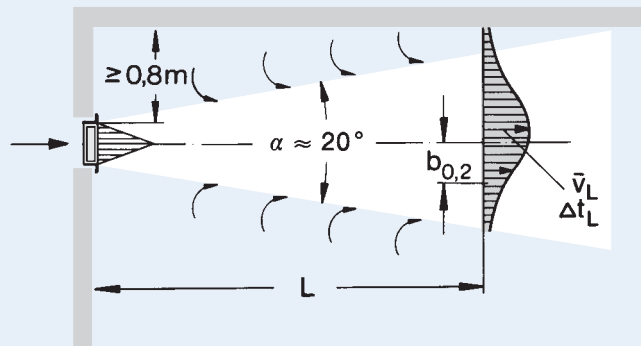

Installation of Linear Grilles :

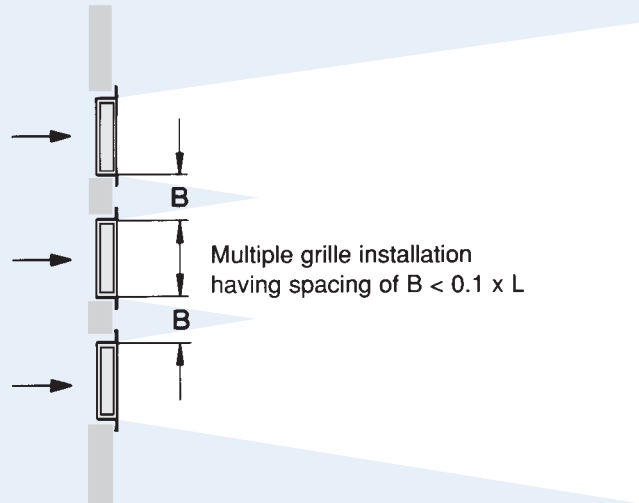
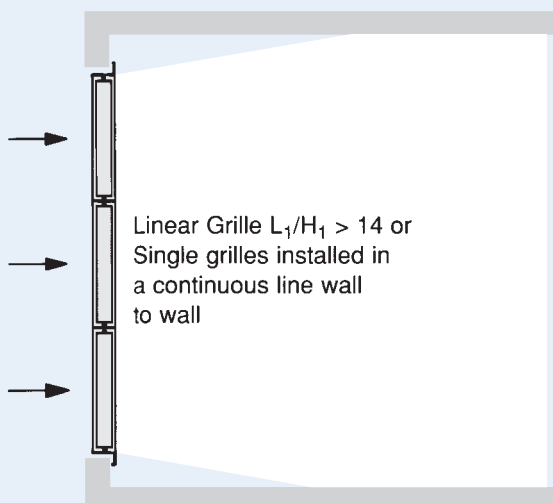

Aerodynamic Data

Linear Grilles with Ceiling Effect

H Type		h _{eff} in mm									
		75	87.5	100	125	150	200	225	250	300	325
AH • AF		0.033	0.040	0.047	-	0.075	0.102	-	0.130	0.158	-
WAP		0.043	0.053	0.062	-	0.099	0.137	-	0.175	0.213	-
SL		-	-	-	0.075	-	-	0.150	-	-	0.225

SELECTION DIAGRAM FOR LINEAR GRILLE WITH ASPECT RATIO > 12 TO 1

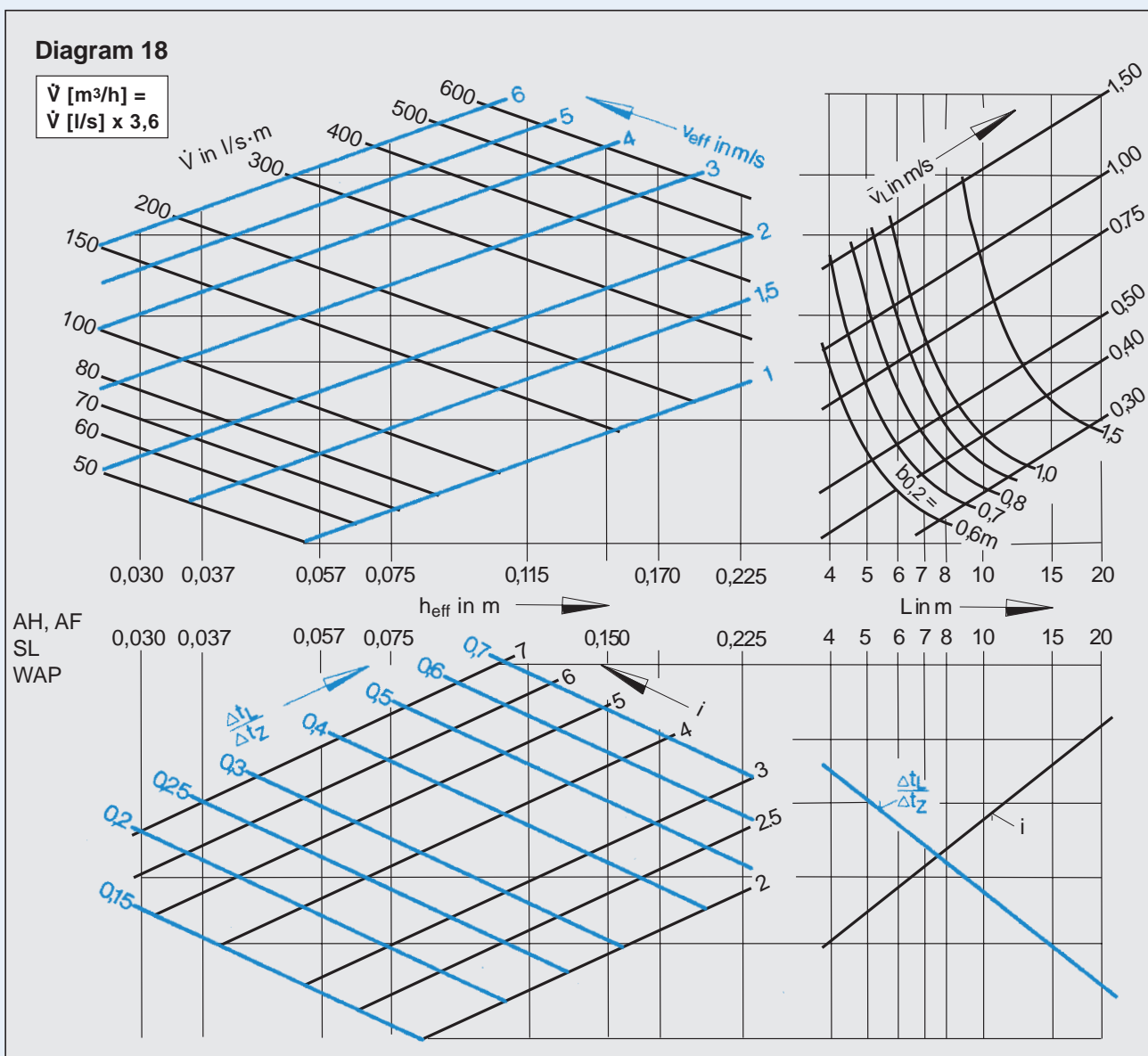

Aerodynamic Data

Linear Grilles

Determination of Volume Flow

The volume flow can be determined by measuring the air velocity with zero blade divergence using either a pitot tube or a rotating vane anemometer.

Pitot Tube (figure 1) :

Measurement of air velocity should be made between the blades at a number of positions to determine an arithmetic mean value - v_{eff} . The volume flow is then calculated as follows :

$$\dot{V} \text{ (l/s)} = v_{eff} \text{ mean (m/s)} \times h_{eff} \text{ (m)} \times L_1 \text{ (m)} \times 1000$$

Rotating Vane Anemometer (figure 2) :

The measurement instrument should be evenly traversed across the entire grille face to determine a value of V_{mean} . The volume flow is then :

$$\dot{V} \text{ (l/s)} = v_{mean} \text{ (m/s)} \times h_{eff} \text{ (m)} \times L_1 \text{ (m)} \times 1000 \times 1.33$$

Volume Flow Measurement :

Figure One :

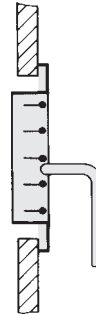
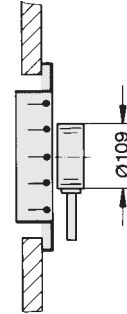
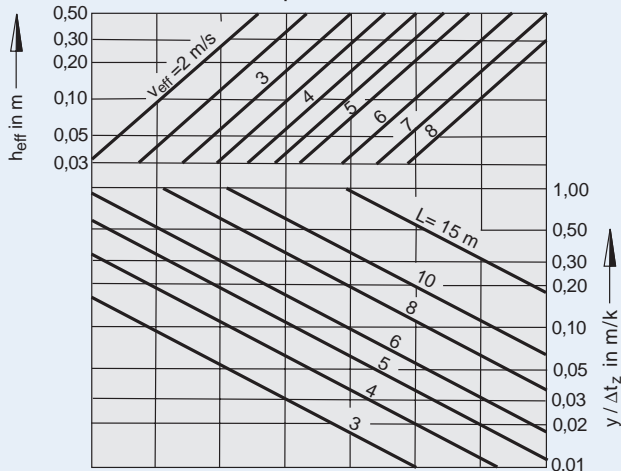

Figure Two :



19 Without ceiling effect : Airstream drop or rise due to temperature difference



On diagram 20 :

To prevent the airstream dropping into the occupied zone reference should be made to diagram 20. This shows the maximum cooling differential which may be used related to the effective outlet height and effective outlet velocity.

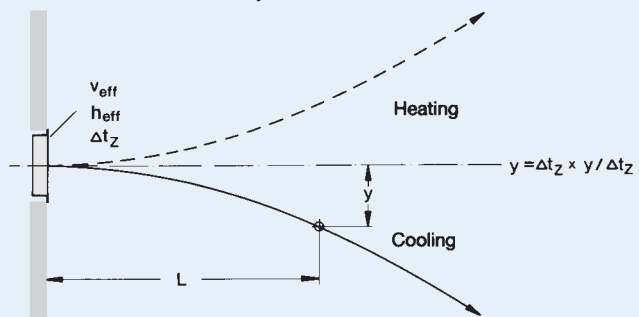

20 With ceiling effect : Maximum temperature difference Δt_z in cooling mode

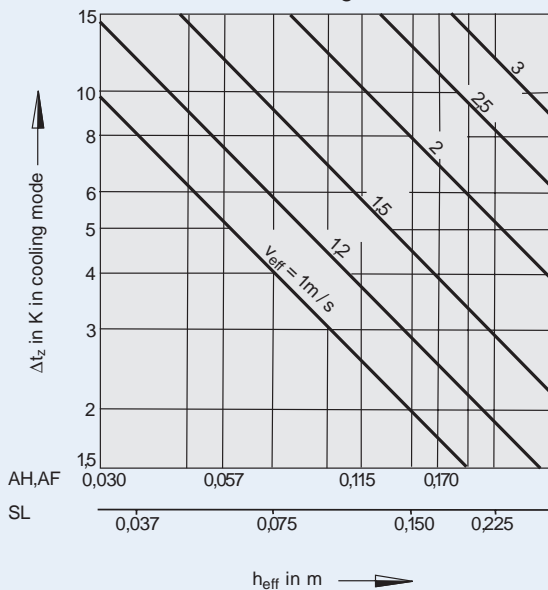

Correction Factors (where L = const.)

with ceiling effect :

without ceiling effect :

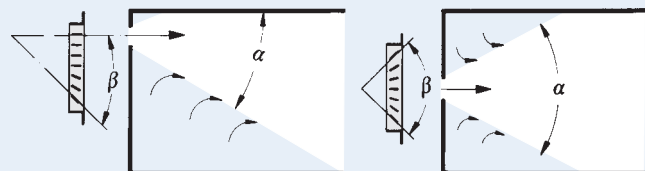

Correction for diagrams 19 & 20 (for setting blade divergence)

β	45°	90°
α	35°	60°
v_L	x 0,7	x 0,5
$\Delta t_L / \Delta t_z$	x 0,7	x 0,5
i	x 1,4	x 2,0

Aerodynamic Data for Return Air Grilles

Volume Flow Measurement

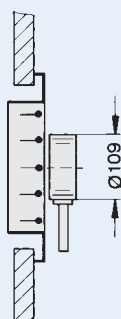

Rotating Vane Anemometer

The measurement instrument should be evenly traversed across the entire grille face to determine a value of v_{mean} . The volume flow is then :

$$\dot{V} \text{ (l/s)} = v_{\text{mean}} \text{ (m/s)} \times A_{\text{eff}} \text{ (m}^2\text{)} \times f \times 1000$$

Correction factor - f -

Type	f
AT·VAT·SL·TR·TRS·ASL	1.6
AH·WAP·AF·AWT	1.9

Effective Inlet Area - A_{eff} in m^2

L x H in mm	Length in mm		
	AWT	TR · TRS TRE · KS	ASL · SL
225 x 75	0.003	0.006	
325	0.005	0.009	
425	0.008	0.011	
525	0.010	0.014	
625	0.011	0.016	
825	0.015	0.022	
1025	0.018	0.028	
1225	0.023	0.033	
225 x 125	0.008	0.011	0.013
325	0.011	0.016	0.019
425	0.015	0.022	0.026
525	0.018	0.028	0.033
625	0.023	0.033	0.040
825	0.029	0.044	0.053
1025	0.036	0.055	0.066
1225	0.043	0.066	0.080
325 x 225	0.023	0.033	0.040
425	0.029	0.044	0.053
525	0.036	0.055	0.066
625	0.043	0.066	0.080
825	0.057	0.090	0.105
1025	0.071	0.110	0.133
1225	0.078	0.134	0.160
425 x 325	0.043	0.066	0.080
525	0.052	0.083	0.100
625	0.063	0.100	0.120
825	0.083	0.134	0.160
1025	0.104	0.170	0.200
1225	0.122	0.200	0.240
625 x 425		0.134	0.160
825		0.180	0.220
1025		0.220	0.270
1225		0.270	0.320
1025 x 525		0.280	0.340
1225		0.340	0.400

A_{eff} for L = 775mm can be interpolated with sufficient accuracy

Aerodynamic Data for Return Air Grilles

Geometric free area

The geometric free area of the AGS can be calculated as follows:

$$A_{\text{geo}} = \frac{(L - 20)}{1000} \times \text{Number of airways} \times 0.0105$$

Note: L is in mm

1 Sound Power Level. Type AGS

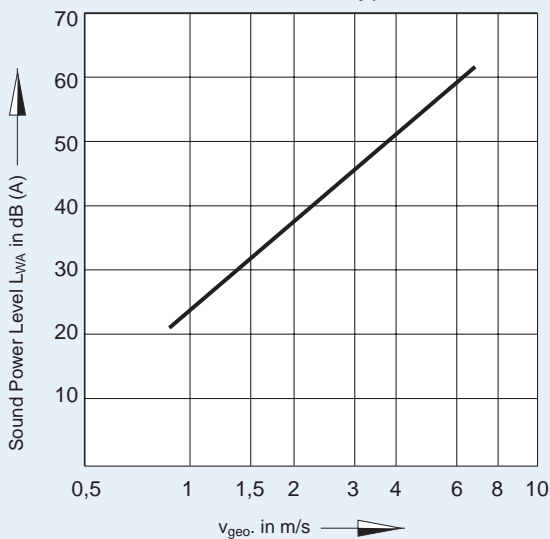

2 Pressure drop. Type AGS

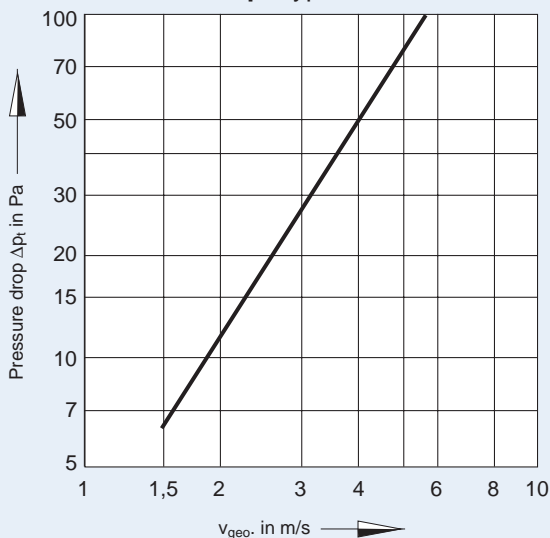

Table of number of airways

H in mm	No. of Airways
100	3
150	5
200	8
250	10
300	13
350	15
400	18
450	20
500	23
600	28

Example : size 300 x 300
 $A_{\text{geo}} = \frac{(300 - 20)}{1000} \times 13 \times 0.0105 = 0.038 \text{ m}^2$

Correction for A_{geo}

A_{geo} in m^2	0,0075	0,015	0,03	0,06	0,12
L_{WA}	- 6	- 3	0	+ 3	+ 6

Aerodynamic Data for Return Air Grilles

Effective Inlet Area - A_{eff} in m^2

H in mm	Type	L Length in mm														
		150	200	250	300	350	400	450	500	600	700	800	900	1000	1100	1200
100	AT · VAT	0.006	0.008	0.010	0.013	0.015	0.017	0.020	0.022	0.026	0.031	0.036	0.040	0.045	0.049	0.054
	AH · AF	-	0.006	0.008	0.010	0.012	0.013	0.015	0.017	0.020	0.024	0.028	0.031	0.035	0.039	0.042
	WAP	-	0.007	0.010	0.013	0.015	0.017	0.019	0.021	0.025	0.030	0.034	0.039	0.043	0.048	0.052
150	AT · VAT	0.010	0.014	0.018	0.022	0.026	0.029	0.033	0.037	0.044	0.052	0.060	0.067	0.075	0.082	0.089
	AH · AF	0.006	0.009	0.012	0.015	0.018	0.021	0.024	0.026	0.032	0.038	0.044	0.050	0.055	0.061	0.067
	WAP	0.008	0.011	0.015	0.019	0.022	0.026	0.029	0.032	0.039	0.045	0.053	0.059	0.067	0.073	0.081
200	AT · VAT	-	0.019	0.024	0.029	0.034	0.039	0.045	0.050	0.060	0.070	0.080	0.091	0.101	0.112	0.122
	AH · AF	-	0.012	0.016	0.021	0.025	0.029	0.032	0.036	0.044	0.052	0.060	0.068	0.076	0.084	0.092
	WAP	-	0.015	0.020	0.026	0.031	0.036	0.041	0.045	0.055	0.065	0.076	0.085	0.095	0.104	0.106
250	AT · VAT	-	-	0.031	0.038	0.044	0.051	0.057	0.064	0.078	0.091	0.105	0.118	0.132	0.147	0.158
	AH · AF	-	-	0.022	0.027	0.032	0.037	0.042	0.046	0.056	0.066	0.077	0.086	0.096	0.106	0.117
	WAP	-	-	0.027	0.033	0.039	0.046	0.052	0.058	0.071	0.084	0.097	0.108	0.121	0.133	0.147
300	AT · VAT	-	-	-	0.045	0.053	0.061	0.069	0.077	0.094	0.110	0.126	0.141	0.153	0.174	0.190
	AH · AF	-	-	-	0.032	0.038	0.045	0.051	0.056	0.068	0.080	0.093	0.104	0.117	0.129	0.136
	WAP	-	-	-	0.041	0.049	0.056	0.063	0.070	0.086	0.101	0.117	0.131	0.147	0.162	0.171
350	AT · VAT	-	-	-	-	0.063	0.072	0.081	0.090	0.109	0.128	0.147	0.165	0.186	0.203	0.221
400	AT · VAT	-	-	-	-	-	0.082	0.094	0.106	0.127	0.148	0.167	0.192	0.215	0.230	0.258
450	AT · VAT	-	-	-	-	-	-	0.103	0.117	0.142	0.167	0.191	0.215	0.240	0.265	0.289
500	AT · VAT	-	-	-	-	-	-	-	0.130	0.158	0.185	0.211	0.239	0.266	0.296	0.323
600	AT · VAT	-	-	-	-	-	-	-	-	0.192	0.211	0.256	0.281	0.324	0.357	0.388

Order Details

Specification Text

Grilles, grille cores and linear grilles suitable for supply or return air for installation in wall, floors or cills; Borders (except grille cores) with corner mitres and rear perimeter sealing strip - horizontal or vertical profiled front blades individually adjustable or fixed. Installation by visible screw fixing (border counter punched) concealed fixing or spring clip fixing. Subframes used where required. For optimum air distribution, rear assemblies are fitted to grilles which can be adjusted directly at the grille face without demounting the face.

Materials

Aluminium

Grille face made from extruded aluminium sections, natural anodised finish or powder coated (RAL 9010).

Steel

Grille face made from formed sheet steel, pre treated and powder coated (RAL 9010).

Galvanised Steel

Grille face made from galvanised sheet steel.

Stainless Steel

Grille face and rear assemblies made from formed, stainless sheet steel, DIN ref. 1.4301 or higher, dull pickled surface, or bright (face of grille only).

Plastic

Grille face and rear assemblies made from plastic extrusions (hard PVC), dark grey colour (similar to RAL 7011), temperature resistant up to 50°C. Curved blades for volume control in black or dark grey.

Order Code

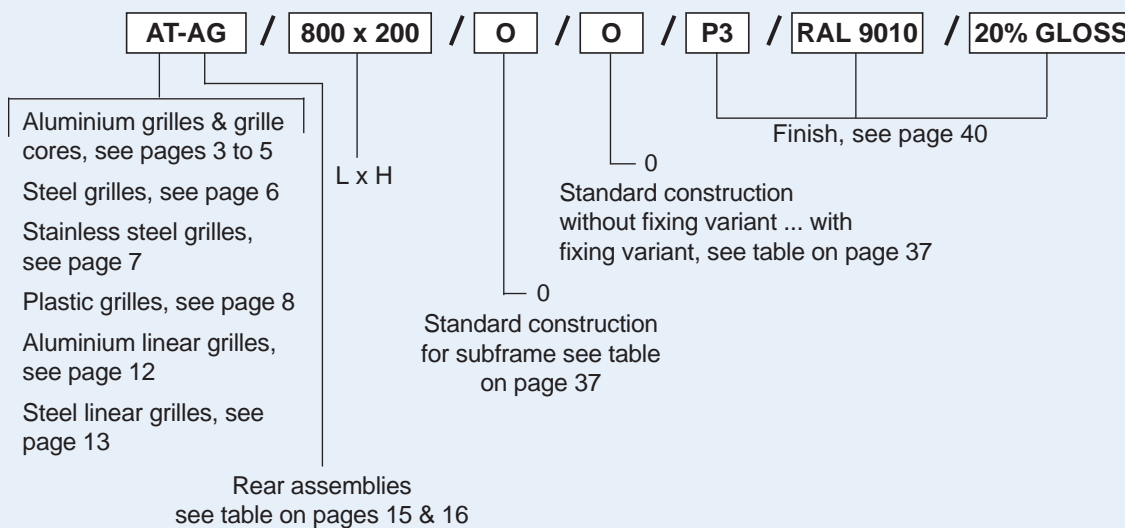

Note: 20mm wide border for types AHR/WAPR

Flow Rate Control Dampers*

AGW · DGW · Z

Rear Assemblies*

E - EF Spare Filter Media

Example : Grille Order with concealed fixing. Standard finish.

Make : Trox

Type : AT - AG / 800 x 200 / B30 / S11 / P3 / RAL 9010 / 20% GLOSS

Example : Linear Grille Order - L = 5200mm (opening size)

Make : Trox

Type : AH - O - A / 5200 x 200 / 0 / 0 / P3 / RAL 9010 / 20% GLOSS

Grille will be supplied in 1800mm intermediate sections (2 off) and 820mm end sections (2 off).

*Please order separately indicating size.

Order Details

Rear Assemblies (grilles made from aluminium)

Rear assemblies made from formed sheet steel, frame and extruded aluminium blades.
stove-enamelled black (RAL 9005).

Type		Without Concealed Fixing	Sub-Frame		Fixing Variations			
			Front Border Width in mm		Front Border Width in mm			
			32 (30)	20	Concealed Fixing	No Screw Holes	Screw Fixing	
			32 (30)	32 (30)	32 (30)	20		
Grilles	AT	0	B30		S11	X	0	
	VAT	0	B30		S11	X	0	
	AH · WAP	0	B30		S11	X	0	
	AF							
	EH · EW							
	AHR · WAPR	0		B20	S11	X		0
	AGS	0					0	
Linear Grilles	End Section	AH · WAP	0	L30		S11	X	0
		AHR · WAPR	0		L20			0
	Intermediate Section	AH · WAP	0	L30		S11	X	0
		AHR · WAPR	0		L20			0

0 = Standard Construction X = Undrilled border

Order Details

(ASL · AWT · SL · TR · TRS · TRE · KS)

Specification Text

Grilles and linear grilles suitable for supply or return air for installation in wall, floors or cills. Borders with corner mitres and rear perimeter sealing strip - horizontal or vertical profiled front blades individually adjustable or fixed. Knock down installation subframes for assembly on site by others, installation by visible screw fixing (border counter punched) concealed fixing or spring clip fixing. For optimum air distribution, rear assemblies are fitted to grilles which can be adjusted directly at the grille face without demounting the face.

Materials:

Aluminium: Grille face made from extruded aluminium sections, natural anodised finish E6-C-0.

Steel: Grille face made from formed sheet steel. The surfaces are pre-treated and powder coated white (RAL 9010).

Galvanised steel: Grille face made from formed galvanised sheet steel.

Stainless steel: Grille face and rear assemblies made from formed, stainless sheet steel, DIN ref. 1.4301 or higher, dull pickled surface, or bright (face of grille only).

Plastic: Grille face and rear assemblies made from plastic extrusions (hard PVC), dark grey colour (similar to RAL 7011), temperature resistant up to 50°C. Curved blades for volume control in black or dark grey.

Order Code

These codes need not be completed for standard products

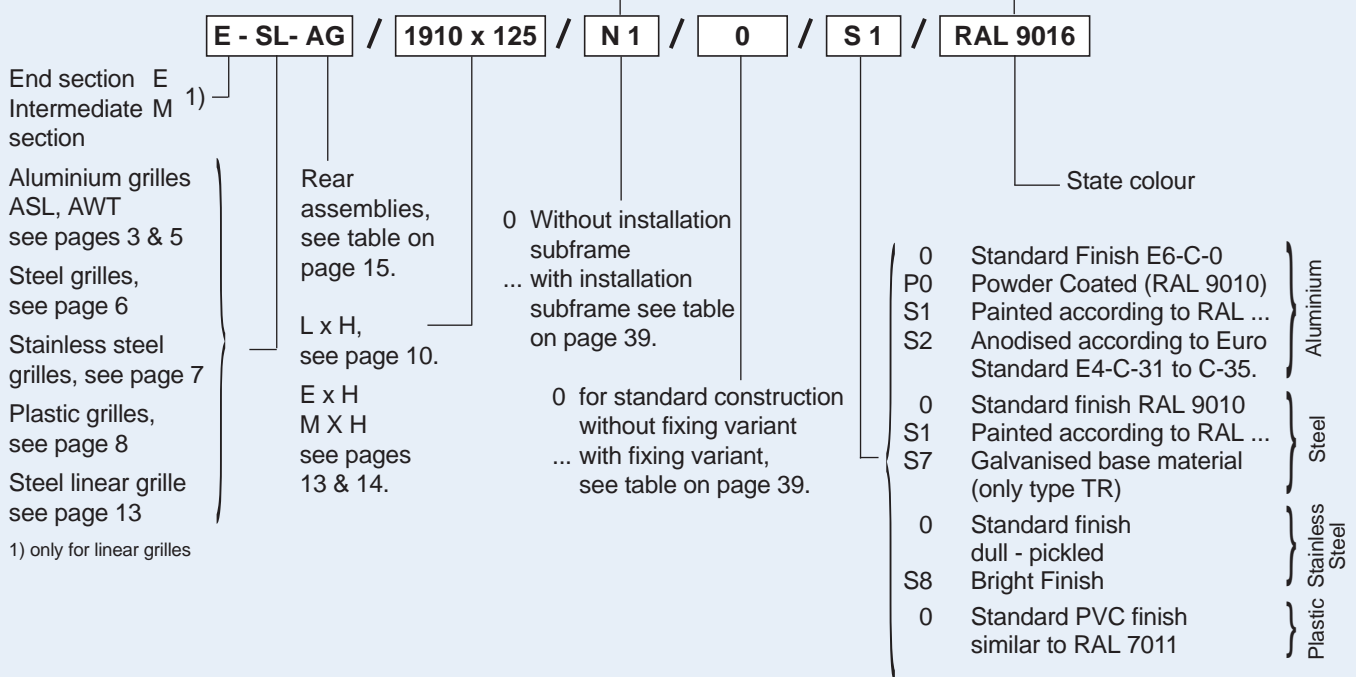

Flow Rate Control Dampers
AGW
DGW
Z

Please order separately indicating size

Rear Assemblies
E-EF spare filter media
AF-90° mitre ¹⁾
ES-AF-0-A
ES-AF-15-A-1
ES-AF-15-A-2

1) Mitre: please order separately with indication of height

Example: Grille Order

Make : Trox
Type : ASL-A / 825 x 225 / A1

Example : Linear Grille Order

Make : Trox
Type : M - SL - AG / 2000 x 125 / E1
E - SL - AG / 1910 x 125 / N1
E - SL - AG / 1850 x 125 / N1

Order Details

Rear Assemblies (grilles made from aluminium, steel or galvanised steel:)

Rear assemblies made from formed sheet steel, phosphate treated, stove enamelled black (RAL 9005) using electro-dipcoat process, resistant to saturated environment for minimum of 100 hours without deterioration (DIN 50 017)

Type		Installation Subframe		Fixing Variations		
		Front Border Width in mm		Concealed fixing 27 (28)	Front Border Width in mm	
27 (28)		28	20		Counterpunched border 25 (TRE and KS) 27 (28)	Spring clip fixing 27 (28)
Grilles	ASL	A1		0		B 11
	AWT	A1			0	
	SL		M 1	0		
	TR	A1		C 11	0	
	TRS	A1		C 11	0	
	TRE				0	
	KS				0	
Linear Grilles	End Section	E - SL		N 1	0	
	Intermediate Section	M - SL		E 1	0	

0 = Standard Construction

Order Details

Alternative Product Finishes

		ALTERNATIVE FINISHES				
Type	Standard Finish	PO/ RAL 9010 / 50%	P2/ RAL 9006 / 25%	P6/ RAL or BS	A1/ MILL FINISH 1)	A3/ NATURAL ANODISED
AT	P3 / RAL 9010 / 20%	✓	✓	✓	✓	✓
VAT	P3 / RAL 9010 / 20%	✓	✓	✓	✓	✓
AF	P2 / RAL 9006 / 25%	✓	STANDARD	✓	✓	✗
AH	P3 / RAL 9010 / 20%	✓	✓	✓	✓	✓
WAP	P3 / RAL 9010 / 20%	✓	✓	✓	✓	✓
ACC	P3 / RAL 9010 / 20%	✓	✓	✓	✓	✓
EH	P3 / RAL 9010 / 20%	✓	✓	✓	✓	✓
EW	P3 / RAL 9010 / 20%	✓	✓	✓	✓	✓
AGS	P3 / RAL 9010 / 20%	✓	✓	✓	✓	✓

NOTE: 1) Mill finish is supplied suitable for finish by others.

		ALTERNATIVE FINISHES						
Type	Standard Finish	PO/ RAL 9010 / 50%	P1/ RAL ...2) / 70%	P3/ RAL 9010 / 20%	S1/ RAL .../11%	S2/ COLOUR...3) ANODISED	S7/ GALVANISED	S8/ BRIGHT FINISH
ASL	0 / E6-C-0	✓	✓	✓	✓	✓	✗	✗
AWT	0 / E6-C-0	✓	✓	✓	✓	✓	✗	✗
SL	0 / RAL 9010 / 50%	STANDARD	✓	✓	✓	✗	✗	✗
TR	0 / RAL 9010 / 50%	STANDARD	✓	✓	✓	✗	✓	✗
TRS	0 / RAL 9010 / 50%	STANDARD	✓	✓	✓	✗	✓	✗
TRE	0 / STAINLESS / MATT	✗	✗	✗	✗	✗	✗	✓
KS	0 / PVC / DARK GREY ¹⁾	✗	✗	✗	✗	✗	✗	✗

NOTE:

- 1) Standard PVC Finish Similar to RAL 7011
- 2) Stock colours RAL 7001, 7035, 9001, 9002, 9003, 9005, 9006, 9016.
- 3) Colour anodised to standard E4-C-31 to E4-C-35