

VARYCONTROL VAV Terminal Units

For variable volume flow systems
Type TVZ · TVA

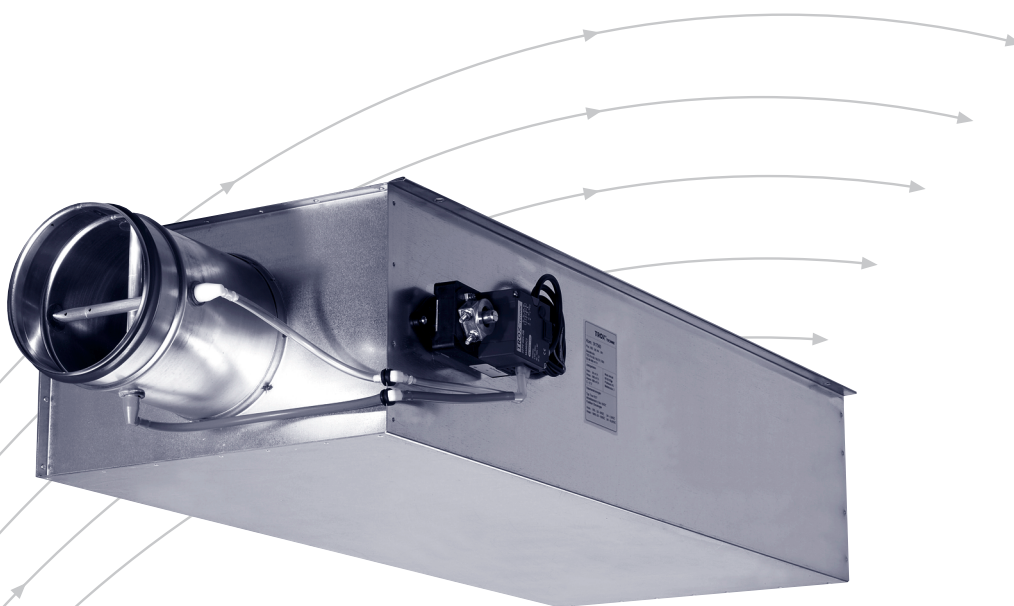

TROX[®] TECHNIK

TROX UK Ltd
Caxton Way
Thetford
Norfolk IP24 3SQ

Telephone +44 (0) 1842 754545
Telefax +44 (0) 1842 763051
e-mail trox@troxuk.co.uk
www.troxuk.co.uk

Contents · Description

Contents · Description	2	Acoustic quick selection TVA · TVAD	15
Functional description	3	Air-regenerated noise TVA · TVAD, without TS secondary silencer	16
Construction · Dimensions	4	Air-regenerated noise TVA · TVAD, with TS secondary silencer	17
Nomenclature	6	Case-radiated noise TVA	18
Aerodynamic data	6	Case-radiated noise TVAD	19
Acoustic quick selection TVZ · TVZD	7	Fan (high pressure) side air-regenerated noise TVA · TVAD	20
Air-regenerated noise TVZ · TVZD, without TS secondary silencer	8	Control code BC0	21
Air-regenerated noise TVZ · TVZD, with TS secondary silencer	9	Temperature Control	22
TVZ air regenerated noise with reheat without TS	10	Electric heater	23
TVZ air regenerated noise with reheat with TS	11	Water heater	24
Case-radiated noise TVZ	12	Order details	25
Case-radiated noise TVZD	13		
Fan (high pressure) side air-regenerated noise TVZ · TVZD	14		

Type TVZ VAV terminal box

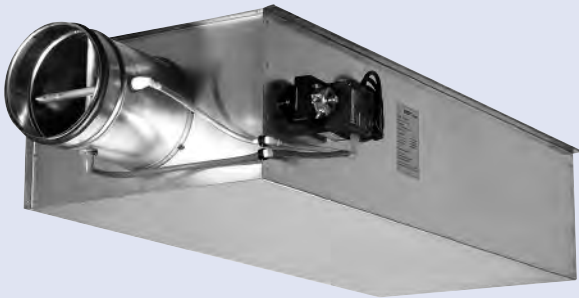

TROX VARYCONTROL VAV terminal boxes type TVZ and TVZD as well as type TVA and TVAD were developed for the control of air flow, especially in variable volume systems. A special feature of these types is the outstanding acoustic qualities that show themselves to the best advantage in buildings with critical comfort criteria.

- TVZ: supply air box
- TVZD: supply air box with additional acoustic cladding
- TVA: extract air box
- TVAD: extract air box with additional acoustic cladding

The mechanical components and electronic components which are factory fitted, form the controls package. Each box is set up to the required flow rates and is subjected to an aerodynamic function test.

The boxes contain an averaging differential pressure sensor for air flow measurement, a control damper and an integral sound attenuator for reducing the air regenerated noise.

The control damper blade with plastic seal when closed complies with the air tightness requirements of EN 1751.

Type TVZD VAV terminal box

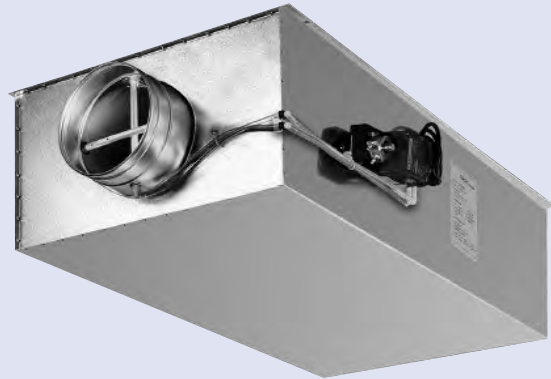

There is a circular spigot connection on the fan (high pressure) end with a rectangular flange connection on the room (low pressure) end.

The boxes with additional acoustic cladding and/or an TS secondary silencer are suitable for very demanding acoustic requirements.

The flow rate control is a closed circuit system with external power supply. The pressure transducer, controller and actuator are selected to meet the controls requirements and operational conditions. The TROX VAV boxes can be supplied with control components from any reputable manufacturer to suit the project specification.

Further, current information on application, selection as well as control components available can be found in the "Technical Documentation" download area of our website.

Also available on the internet is TROX EASY PRODUCT FINDER for design and selection of our units.

Room temperature controller

In VAV systems, the room temperature control takes the form of a cascade control. The primary controlled variable is the room temperature. The output signal of the room temperature controller is not fed directly to the supply air control damper but alters the setpoint value of the supply air flow rate control circuit. The flow rate control also generates minimum and maximum limits for the air flow which has benefits in keeping the room temperature constant and for the functioning of the overall room air conditioning system.

Flow rate measurement

A sensor is necessary for the positive measurement of air flows, this is achieved by pressure measurement at several points distributed over the cross-section and provision of the resulting average value. The TROX differential pressure sensor is an optimum solution in terms of economics and product technology. This sensor delivers exact results for most room air conditioning applications based on normal upstream flow conditions.

Volume flow control

The control of the flow rate takes place in a closed control circuit, i.e. measurement – comparison – control.

A pressure transducer converts the pressure differential into an electrical signal, which is interpreted as the actual value by the controller. In most applications, the setpoint value comes from a room temperature controller.

The controller compares the actual value with the setpoint value and from the difference between these two alters the control signal to the damper actuator.

Supply/extract air tracking control

In individual rooms and closed-off office areas, where the balance between supply and extract air flow rate has to be maintained. Otherwise, annoying whistling noises can occur at door gaps, and the doors can be difficult to open. For this reason, the extract air should also have variable control in a VAV system.

The actual value of the supply air is fed as an input signal to the extract air controller (slave controller). In this way, the extract air flow rate automatically follows the supply air flow rate, even in the case where this has not reached its setpoint value.

System diagram

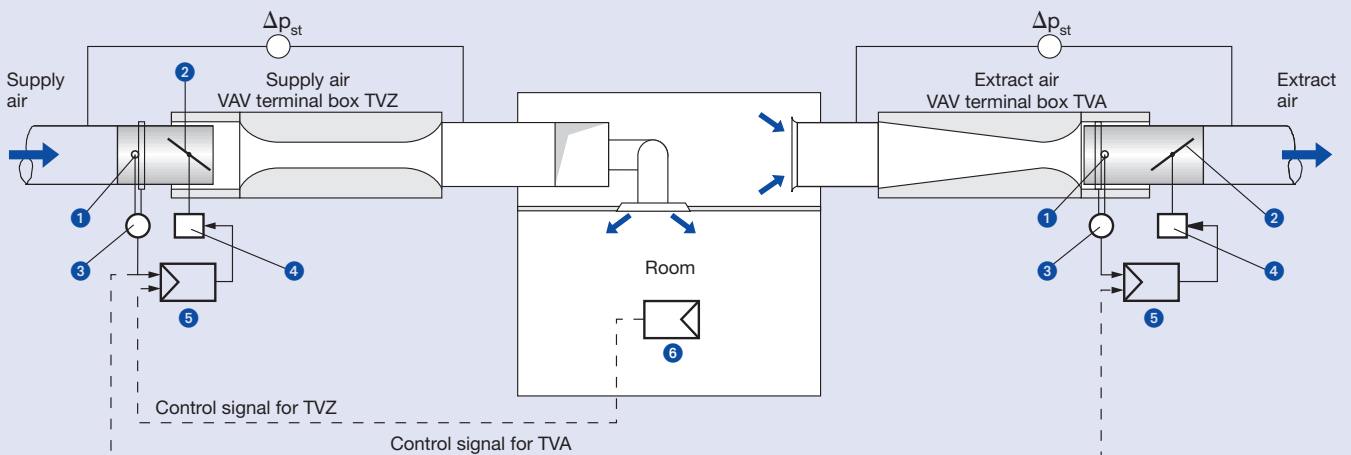

Legend

- 1 Differential pressure sensor
- 2 Control damper blade
- 3 Pressure transducer
- 4 Actuator
- 5 Flow rate controller
- 6 Room temperature controller (supplied by others)
Wiring by others

Entry flow conditions

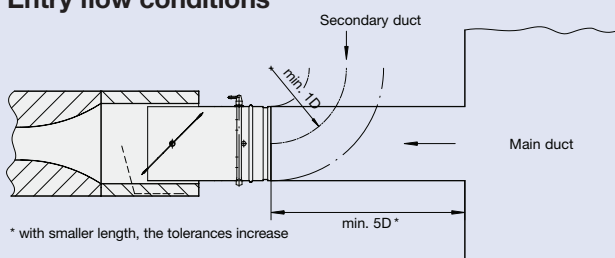

Control diagram

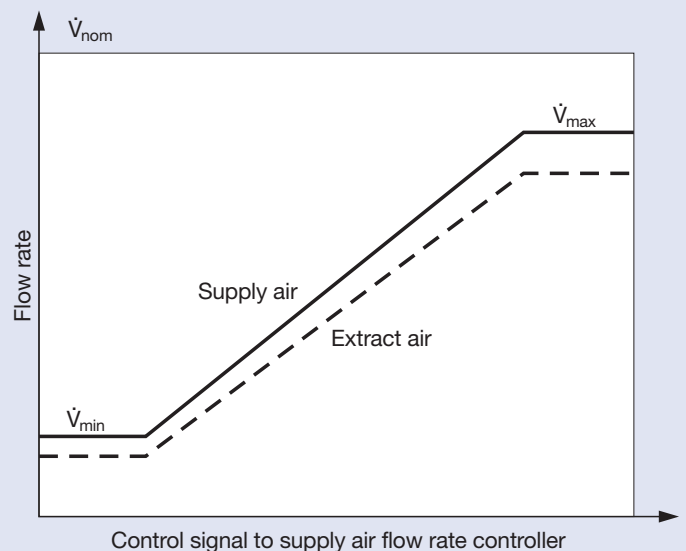

Construction · Dimensions

Characteristics

- Electronic flow rate control
- Suitable for supply or extract air
- Flow rate range (depending on manufacturer and type of controller) approx. 10:1
- Very close control accuracy for the flow rate settings, even with upstream bend at $R = 1 D$. Please ensure the most favourable aerodynamic configuration of ductwork is used (see diagram on page 3)
- Differential pressure range 20 to 1500 Pa
- Full shut-off from duct work system
- Control damper closed blade airtightness to EN 1751, class 4 (nominal size 125, class 3)
- Baffle plates are fitted after the control damper for optimum acoustic and aerodynamic performance
- Integral sound attenuator with at least 26 dB insertion loss at 250 Hz
- Horizontal or vertical installation (when using diaphragm pressure transducers, install according to label on the box)

- Factory set up or programming of flow rate. This includes aerodynamic function test of each box using a dedicated test rig. Data covering set up is given on a test label attached to each box
- Flow rate can be measured and subsequently reset on site; an additional adjuster unit may be necessary
- Actual value signal referred to V_{nom}
- The boxes are, in terms of their mechanical parts, maintenance-free
- Operating temperature range 10 to 50 °C

Constructional features

- Circular spigot on the fan (high pressure) side, this includes a groove for the use of a lip seal, suitable for circular connecting ducts to EN 1506 or EN 13180 (if lip seals are required, these will be factory fitted)
- Room (low pressure) side suitable for attachment of connecting flanges
- Holes in the return edges of the casing for support rods
- Casing air leakage complies with EN 1751, class A
- Fulfils VDI 2083, clean room class 3 and US Federal Standard 209E, class 100

TVZ · TVA

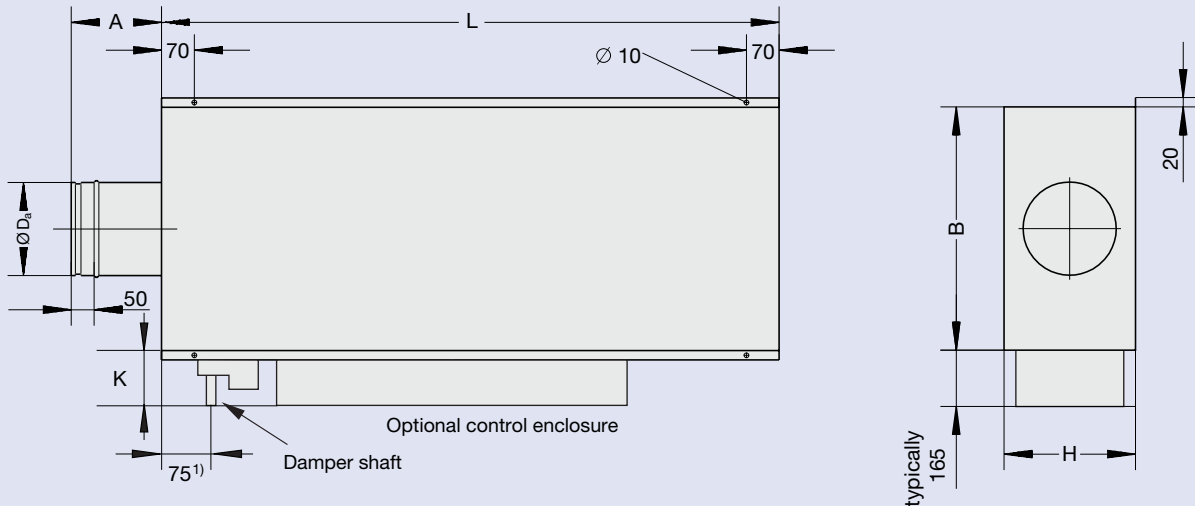

TVZD · TVAD

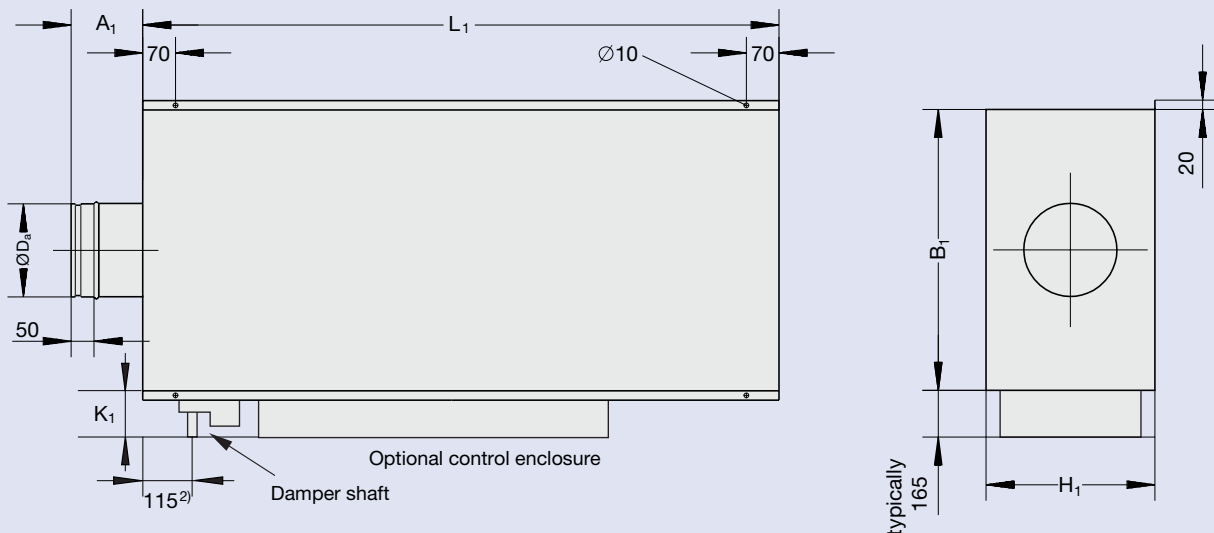

Note: ¹) 100 for size 250, 315 & 400 ²) 140 for size 250, 315 & 400

Ensure adequate access is provided to control components.

Control components are situated on the right hand side when seen from the direction of airflow (with the folded seam upper most)!

Casing

- Casing in galvanised sheet steel
- Lining in the sound attenuator section and in the control damper chamber from mineral wool conforming to DIN 4102, fire rating class A2, with RAL quality mark RAL-GZ 388, bio-degradable pursuant to TRGS 905 and EU directive 97/69/EG
- Mineral wool faced with fibreglass as protection against erosion, suitable for air velocities up to 20 m/s, inert to fungal and bacterial growth
- Control damper blade in galvanised sheet steel with thermoplastic elastomer seal
- Sensor tubes in aluminium
- Plastic plain bearings

Additional acoustic cladding

- Outer cover in galvanised sheet steel
- Sound-absorbent lining
- Rubber isolators for the insulation of structure-borne noise
- Cannot be retro-fitted

TS Secondary silencer

- Casing in galvanised sheet steel
- Lining from mineral wool conforming to DIN 4102, fire rating class A2, with RAL quality mark RAL-GZ 388, bio-degradable pursuant to TRGS 905 and EU directive 97/69/EG
- Mineral wool faced with fibreglass as protection against erosion, suitable for air velocities up to 20 m/s, inert to fungal and bacterial growth
- Suitable for the TVZ/TVA box
- Suitable for attachment of connecting flanges

Reheat Coil

- For terminal reheat of primary air volume
- Casing made of galvanised sheet steel
- Flanged on both ends
- Copper tubes and aluminium fins
- One or two row (four-row formed by combination)
- Available factory-fitted or supplied separately
- Maximum operating pressure 16 bar
- Water connections horizontal, air venting by customer

TS Secondary Silencer

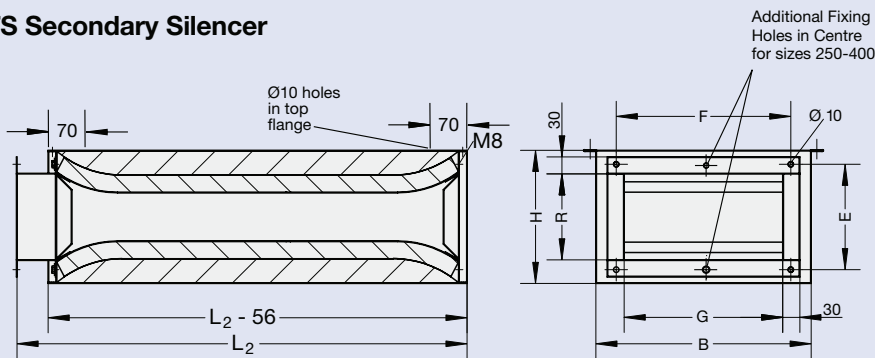

TS or duct connection

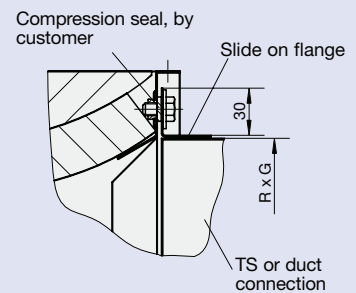

Rectangular duct connection

Additional Fixing Holes in Centre for sizes 250-400

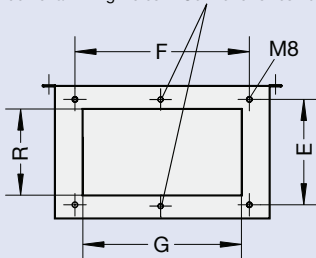

Reheat Coil ⁴⁾

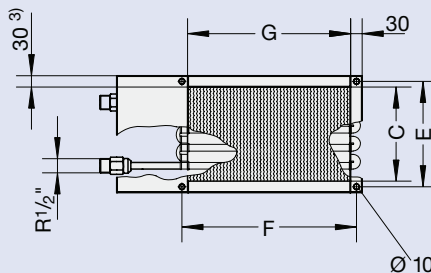

Reheat coil connection

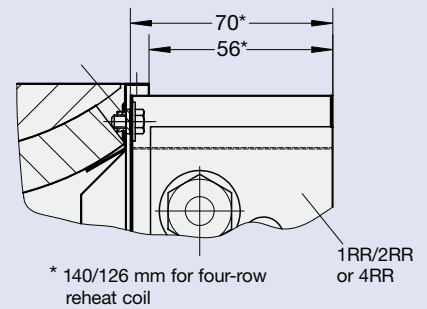

Dimensions in mm

Size	Duct connections					Casing																
	Ø D _a	E	F	R	G	TVZ	A	TVA	TVZD	A ₁	TVAD	B	B ₁	C	H	H ₁	K	K ₁	L	L ₁	L ₂	
125	124	186	232	152	198	150	185	110	145	300	380	152	236	316	56	56	1035	1075	806			
160	159	186	342	152	308	200	170	160	130	410	490	152	236	316	62	72	1035	1075	806			
200	199	244	492	210	458	200	140	160	100	560	640	203	281	361	53	58	1320	1360	956			
250	249	235	632	201	598	250	100	210	60	700	780	203	311	391	57	57	1440	1480	956			
315	314	286	832	252	798	250	250	210	210	900	980	254	361	441	70	70	1440	1480	1056			
400	399	388	932	354	898	250	180	210	140	1000	1080	356	446	526	62	62	1820	1860	1306			

Weight in kg

Nom. size	Weight in kg			
	TVZ TVA	TVZD TVAD	TS	Reheat Coil (2RR)
125	21	41	10	2.4
160	25	50	15	3.3
200	33	63	22	4.8
250	55	95	37	6.0
315	73	133	42	8.7
400	118	193	50	12.7

Note ³⁾ 25 for size 400 ⁴⁾ Duct connection dimensions R x G

Nomenclature · Aerodynamic Data

Nomenclature

f_m	in Hz:	Octave band centre frequency
L_W	in dB:	Sound power level of the air-regenerated noise in the room (low pressure) side ducting
L_{W1}	in dB:	Sound power level of the air-regenerated noise with TS secondary silencer
L_{W2}	in dB:	Sound power level of the case-radiated noise
L_{W3}	in dB:	Sound power level of the case-radiated noise with additional acoustic cladding
L_{WR}	in dB:	Sound power level of the air-regenerated noise in the fan (high pressure) side ducting
L_{pA}	in dB(A):	A-weighted sound pressure level of air-regenerated noise, system attenuation taken into account
L_{pA1}	in dB(A):	A-weighted sound pressure level of air-regenerated noise with TS secondary silencer, system attenuation taken into account
L_{pA2}	in dB(A):	A-weighted sound pressure level of case-radiated noise, system attenuation taken into account
L_{pA3}	in dB(A):	A-weighted sound pressure level of case-radiated noise with additional acoustic cladding, system attenuation taken into account
D_e	in dB:	Insertion loss
\dot{V}_{nom}	in m ³ /h and l/s:	Nominal flow rate (100 %)
\dot{V}	in m ³ /h and l/s:	Flow rate
$\Delta \dot{V}$	in ± %:	Flow rate tolerance from setpoint value

Δp_{st}	in Pa:	Static pressure differential
$\Delta p_{st min}$	in Pa:	Minimum static pressure differential
NR :		Noise Rating of sound pressure spectrum, assuming a 8 dB/oct. room attenuation.
L in dB(A) :		A-weighted sound pressure (re 20µPa) of air-regenerated noise, assuming reflection attenuation and 8 dB/Oct. room attenuation.
L indBor	NC:	Level correction values for TVZ with air heater
RR:		Number of rows
K:		Number of circuits (distributors)
\dot{m}_w	in kg/s:	Mass flow (water)
\dot{m}_{wk}	in kg/s:	Mass flow per circuit
\dot{Q}_{wk}	in kW:	Heat output
t_e	in °C:	Inlet air temperature
t_a	in °C:	Discharge air temperature
t_{wm}	in °C:	Mean water temperature
v	in m/s:	Air velocity in rectangular duct
Δp_v	in kPa:	Water pressure drop
Δt	in K:	Air temperature differential
Δt_w	in K:	Water temperature differential

All sound power levels are based on 1 pW, all sound pressure levels on 20 µPa.

All noise levels determined in a reverberation chamber. The sound power data was determined and corrected according to ISO EN 5135, February 1999.

Flow rate ranges and minimum pressure differentials with dynamic pressure transducer

Nominal size	\dot{V}		$\dot{V}^{1)}$	$\Delta p_{st min}$ in Pa				
	l/s	m ³ /h		± %	TVZ	TVZ with reheat coil		TVA
			1RR			2RR		
125	15	54	19	20	20	40	20	–
	60	216	8	20	30	40	25	5
	105	378	7	45	80	110	80	20
	150	540	5	90	140	190	150	40
160	25	90	19	20	20	20	20	–
	80	288	8	20	30	40	25	5
	145	522	7	45	55	80	50	10
	250	900	5	80	140	200	150	20
200	40	144	19	20	20	20	20	–
	180	648	8	20	30	40	30	5
	310	1116	7	40	70	100	95	10
	405	1458	5	80	130	180	190	20
250	60	216	19	20	20	20	20	–
	270	972	8	20	35	45	25	5
	470	1692	7	40	80	110	75	10
	615	2214	5	80	145	210	150	20
315	105	378	19	20	20	10	20	5
	425	1530	8	20	35	45	30	10
	740	2664	7	40	75	110	90	20
	1025	3690	5	80	140	195	180	40
400	170	612	19	20	20	20	20	5
	715	2574	8	20	35	50	25	10
	1250	4500	7	40	80	120	75	20
	1680	6048	5	80	150	210	150	40

¹⁾ typical figures for uniform entry flow

²⁾ additional pressure differential to be taken into account

Acoustic Quick Selection TVZ · TVZD

System attenuation in dB/oct. acc. to VDI 2081 (taken into account in the quick selection table)

f_m in Hz	63	125	250	500	1000	2000	4000	8000
Duct bend attenuation	0	0	1	2	3	3	3	3
Room attenuation	5	5	5	5	5	5	5	5
End reflection	10	5	2	0	0	0	0	0

Correction for distribution into the low pressure duct system (taken into account in the quick selection table)

\dot{V}	m ³ /h	500	1000	1500	2000	2500	3000	4000	5000	6000
	l/s	139	278	417	556	695	834	1111	1389	1667
dB per octave		0	3	5	6	7	8	9	10	11

Correction for the calculation of the case-radiated noise (taken into account in the quick selection table)

Ceiling reduction in dB/oct.	4
Room attenuation in dB/oct.	5

Quick selection sound pressure level in dB(A)

Nominal size	\dot{V}		$\Delta p_{st} = 100 \text{ Pa}$				$\Delta p_{st} = 200 \text{ Pa}$				$\Delta p_{st} = 500 \text{ Pa}$			
			Air-regenerated noise		Case-radiated noise		Air-regenerated noise		Case-radiated noise		Air-regenerated noise		Case-radiated noise	
			TVZ L_{pA}	TVZ+TS L_{pA1}	TVZ L_{pA2}	TVZD L_{pA3}	TVZ L_{pA}	TVZ+TS L_{pA1}	TVZ L_{pA2}	TVZD L_{pA3}	TVZ L_{pA}	TVZ+TS L_{pA1}	TVZ L_{pA2}	TVZD L_{pA3}
125	15	54	15	15	20	13	18	14	21	13	19	14	23	14
	60	216	22	19	21	15	25	15	25	16	26	16	31	21
	105	378	28	23	25	18	29	16	29	20	35	20	34	24
	150	540	34	28	30	22	37	23	33	24	40	25	36	27
160	25	90	16	15	17	13	22	14	19	13	20	14	25	15
	100	360	28	23	22	16	29	17	25	18	32	18	32	23
	175	630	33	27	26	19	36	21	30	22	37	22	36	27
	250	900	35	29	32	24	37	22	35	27	41	26	39	31
200	40	144	15	14	19	14	17	14	22	14	19	14	29	18
	160	576	20	17	24	18	22	13	28	20	28	15	35	25
	280	1008	21	16	28	21	24	13	32	24	30	16	38	29
	405	1458	30	23	36	29	32	17	39	31	34	21	43	34
250	60	216	15	14	19	14	17	14	23	15	19	14	29	18
	250	900	17	14	23	18	20	12	28	20	26	15	35	26
	430	1548	23	14	26	20	26	14	31	24	30	19	38	30
	615	2214	29	20	34	26	32	18	38	30	36	24	43	35
315	100	360	17	15	19	14	18	14	22	14	22	15	31	20
	410	1476	19	15	23	17	23	14	29	21	32	22	39	29
	720	2592	21	16	30	22	25	18	35	26	33	24	42	33
	1025	3690	28	20	35	28	31	20	40	31	37	27	45	37
400	170	612	16	14	22	15	18	13	26	18	23	16	34	24
	671	2416	18	13	25	19	22	15	31	23	30	22	42	32
	1175	4230	25	19	31	25	28	22	35	29	32	26	43	34
	1680	6048	31	26	43	37	34	26	45	40	38	31	48	42

For acoustic data for differential pressure up to 1000 Pa, refer to TROX EASY PRODUCT FINDER

Air-regenerated Noise TVZ · TVZD

without TS secondary silencer

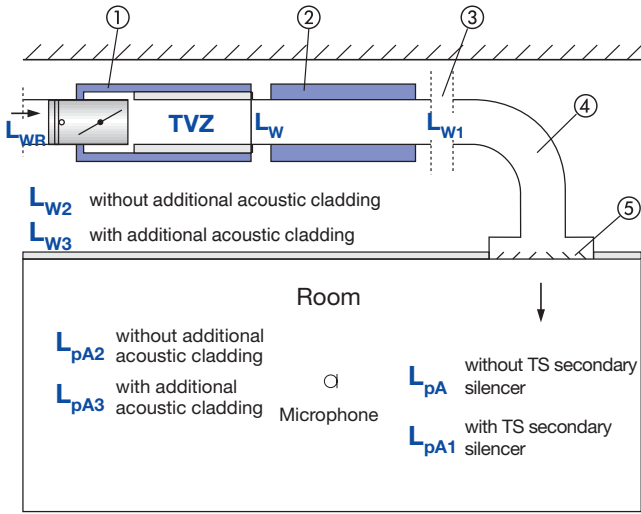

Nomenclature, see page 6

- ① Additional acoustic cladding
- ② TS secondary silencer
- ③ Air distributed between several diffusers
- ④ Duct bend
- ⑤ End reflection based on diffuser

Type / nominal size		Insertion loss							
		D_e in dB							
		f_m in Hz							
		63	125	250	500	1000	2000	4000	8000
TVZ 125 to 200 without TS		15	18	26	37	42	39	32	23
TVZ 125 to 200 with TS		21	25	32	47	47	45	37	29
TVZ 250 to 400 without TS		20	25	31	45	45	42	37	31
TVZ 250 to 400 with TS		25	32	42	53	52	50	45	38

Air-regenerated noise TVZ without TS secondary silencer																										
Nominal size	\dot{V}		$\Delta p_{st} = 100 \text{ Pa}$								$\Delta p_{st} = 200 \text{ Pa}$								$\Delta p_{st} = 500 \text{ Pa}$							
			L_w in dB								L_w in dB								L_w in dB							
			f_m in Hz								f_m in Hz								f_m in Hz							
			63	125	250	500	1000	2000	4000	8000	63	125	250	500	1000	2000	4000	8000	63	125	250	500	1000	2000	4000	8000
l/s	m ³ /h	63	125	250	500	1000	2000	4000	8000	63	125	250	500	1000	2000	4000	8000	63	125	250	500	1000	2000	4000	8000	
125	15	54	50	26	18	15	15	15	15	16	55	32	25	16	<	<	<	19	56	31	25	16	<	<	<	22
	60	216	47	44	35	18	15	15	15	15	51	47	37	22	<	<	<	22	53	46	41	26	<	<	15	22
	105	378	54	50	41	25	16	15	15	15	57	51	43	28	19	<	<	19	58	58	47	32	20	<	18	28
	150	540	56	51	49	36	23	15	15	15	59	54	51	42	37	33	19	20	62	60	55	38	28	20	18	29
160	25	90	50	33	24	15	15	15	15	15	53	45	29	17	<	<	<	19	55	37	29	20	<	<	<	19
	100	360	52	52	39	21	15	21	16	16	55	53	41	25	15	<	19	21	56	54	45	34	26	23	21	23
	175	630	55	54	49	30	23	15	15	15	58	56	52	33	25	17	17	20	60	60	52	37	28	20	18	27
	250	900	63	59	51	38	33	27	17	16	65	61	53	40	35	29	21	22	66	66	56	44	38	33	25	31
200	40	144	33	29	23	15	15	15	15	17	51	32	26	15	<	<	15	20	42	33	29	19	16	<	<	23
	160	576	46	43	33	16	15	15	15	15	50	45	36	21	<	<	<	<	58	49	41	30	15	<	<	25
	280	1008	51	45	37	27	21	15	15	15	55	48	40	31	23	17	<	19	58	53	47	34	25	18	<	28
	405	1458	59	54	46	38	33	28	21	15	64	56	49	40	35	30	24	22	64	57	50	44	39	34	27	31
250	60	216	36	34	20	15	15	15	15	15	42	36	25	15	<	<	<	18	46	40	28	15	<	<	<	20
	250	900	47	42	28	17	15	15	15	15	50	45	33	22	15	<	<	18	55	50	41	29	22	20	21	26
	430	1548	52	45	36	33	28	24	21	25	56	50	41	36	31	27	24	28	59	57	46	37	32	28	27	31
	615	2214	60	52	44	40	36	33	32	33	63	56	48	43	39	36	34	36	66	60	52	46	42	39	36	39
315	100	360	35	36	28	15	15	15	15	15	41	37	31	15	<	<	<	<	49	38	35	23	17	<	<	22
	410	1476	49	46	37	16	15	15	15	25	53	49	41	22	<	<	15	29	61	58	49	33	31	29	30	37
	720	2592	57	47	38	25	21	15	23	34	60	52	43	30	26	20	27	37	65	60	51	39	37	35	35	42
	1025	3690	65	54	49	37	34	31	29	34	67	58	53	41	37	34	34	38	72	65	54	47	45	42	41	45
400	170	612	35	35	28	15	15	15	15	15	41	38	32	<	<	<	<	<	41	43	37	24	16	<	20	25
	671	2416	51	48	34	22	19	18	19	23	54	51	39	27	24	23	26	30	58	56	50	34	31	30	34	38
	1175	4230	66	53	43	36	35	30	30	35	67	56	47	39	37	33	34	39	69	61	52	40	38	36	39	44
	1680	6048	72	63	45	42	39	39	37	41	78	65	50	45	42	41	41	45	78	67	57	50	49	46	46	50

< indicates values below 15

Air-regenerated Noise TVZ · TVZD

with TS secondary silencer

Example

Given: $\dot{V}_{max} = 280 \text{ l/s (1008 m}^3\text{/h)}$
 $\Delta p_{st} = 500 \text{ Pa}$
 Required sound pressure level in the room 35 dB(A)
 For further assumptions, see calculation procedure

Calculation procedure

Quick selection:

TVZD 200

$L_{pA} = 30 \text{ dB(A)}$

$L_{pA3} = 29 \text{ dB(A)}$

Total sound pressure level in the room = 33 dB(A)
 (after logarithmic addition, as the box is in the false ceiling of the room, see sketch on page 8)

Air-regenerated noise calculation procedure

f_m	63	125	250	500	1000	2000	4000	8000
L_w (page 8)	58	53	47	34	25	18	15	28
Distribution	3	3	3	3	3	3	3	3
Duct bend	0	0	1	2	3	3	3	3
End reflection	10	5	2	0	0	0	0	0
Sound power level to room	45	45	41	29	19	12	9	22
Room attenuation	6	6	5	5	4	4	4	4
A-weighting	-26	-16	-9	-3	0	+1	+1	-1
Corrected level	13	23	27	21	15	9	6	17

Sound pressure level of the air regenerated noise $L_{pA} = 30 \text{ dB(A)}$

Air-regenerated noise TVZ with TS secondary silencer

Nominal size	\dot{V}		$\Delta p_{st} = 100 \text{ Pa}$								$\Delta p_{st} = 200 \text{ Pa}$								$\Delta p_{st} = 500 \text{ Pa}$							
			L_w in dB								L_w in dB								L_w in dB							
			f_m in Hz								f_m in Hz								f_m in Hz							
			63	125	250	500	1000	2000	4000	8000	63	125	250	500	1000	2000	4000	8000	63	125	250	500	1000	2000	4000	8000
125	15	54	49	22	15	15	15	15	15	53	29	21	<	<	<	<	<	54	28	21	<	<	<	<	15	
	60	216	45	40	30	15	15	15	15	49	43	32	16	<	<	<	15	51	42	36	16	<	<	<	15	
	105	378	51	45	36	15	15	15	15	54	47	38	16	<	<	<	<	55	54	42	19	<	<	<	20	
	150	540	52	48	44	26	21	17	15	57	50	46	27	22	19	<	<	58	55	49	28	23	18	<	21	
160	25	90	48	27	17	15	15	15	15	51	41	22	<	<	<	<	<	53	33	22	<	<	<	<	<	
	100	360	50	48	32	15	15	15	15	53	49	34	15	<	<	<	16	54	50	38	20	<	<	<	18	
	175	630	52	50	43	17	15	15	15	55	52	45	19	<	<	<	15	58	56	45	23	15	<	<	21	
	250	900	60	55	44	23	18	15	15	63	57	46	25	20	16	<	17	64	62	49	30	25	20	<	25	
200	40	144	34	25	15	15	15	15	15	49	28	18	<	<	<	<	<	40	29	21	<	<	<	<	<	
	160	576	44	39	25	15	15	15	15	48	41	28	15	<	<	<	<	56	45	33	20	<	<	<	<	
	280	1008	49	41	29	18	15	15	15	53	44	32	21	<	<	<	<	56	49	39	24	15	<	<	15	
	405	1458	58	50	39	27	17	15	15	61	52	41	29	21	<	<	<	62	53	43	35	29	23	17	18	
250	60	216	34	30	15	15	15	15	15	40	32	16	<	<	<	<	<	44	36	18	<	<	<	<	<	
	250	900	45	38	18	15	15	15	15	48	41	23	15	<	<	<	<	53	46	31	16	<	<	<	19	
	430	1548	50	41	26	20	15	15	15	54	46	31	22	17	<	<	20	57	53	37	28	23	18	<	23	
	615	2214	58	48	34	27	23	18	18	61	52	38	28	24	21	20	28	64	56	44	37	33	29	24	31	
315	100	360	33	32	19	15	15	15	15	39	33	22	<	<	<	<	<	47	34	26	<	<	<	<	16	
	410	1476	47	42	28	15	15	15	19	51	45	32	<	<	<	<	23	59	54	40	20	19	17	19	31	
	720	2592	55	43	29	15	15	16	15	58	48	34	18	15	<	17	31	63	56	42	29	26	23	24	36	
	1025	3690	63	50	40	24	21	19	19	65	54	44	28	25	22	23	32	70	61	46	39	35	31	31	39	
400	170	612	32	31	19	15	15	15	15	39	34	23	<	<	<	<	<	39	39	28	<	<	<	<	21	
	671	2416	49	44	25	15	15	15	19	52	47	30	18	15	15	20	26	56	52	41	24	21	20	27	34	
	1175	4230	64	49	34	27	25	20	23	65	52	38	29	27	23	27	35	67	57	43	31	29	26	32	40	
	1680	6048	73	59	36	32	29	29	30	76	61	41	35	32	31	34	41	76	63	48	41	40	36	39	46	

< indicates values below 15

TVZ Air-Regenerated Noise with Reheat Coil

without TS secondary silencer

Correction Values

Number of rows	1RR	2RR	4RR ¹⁾
ΔL in dB	-2	0	3

Note: ¹⁾ minimum pressure differential as in page 6.

Air-regenerated noise TVZ with Reheat coil without TS secondary silencer																		
Nominal size	\dot{V}		$\Delta p_{st} = 200 \text{ Pa}$								$\Delta p_{st} = 500 \text{ Pa}$							
			L_w in dB								L_w in dB							
			f_m in Hz								f_m in Hz							
			63	125	250	500	1000	2000	4000	8000	63	125	250	500	1000	2000	4000	8000
I/s	m ³ /h																	
125	15	54	55	32	25	16	<	<	<	19	56	31	25	16	<	<	<	22
	35	126	57	43	35	18	<	<	<	21	60	41	36	23	<	<	<	23
	60	216	51	47	37	24	17	15	15	22	53	46	41	27	19	17	17	22
	95	342	57	51	44	33	30	27	25	23	58	58	47	35	31	28	26	29
	150	540	61	56	52	45	42	39	35	33	62	60	55	44	41	38	37	35
160	25	90	53	45	29	17	<	<	<	19	55	37	29	20	16	<	<	19
	65	234	52	48	40	23	<	<	<	20	54	49	41	28	17	<	<	23
	100	360	55	53	41	27	21	19	20	21	56	54	45	34	27	24	22	23
	170	612	58	56	52	37	33	31	29	27	60	60	52	40	35	32	30	30
	250	900	66	62	55	47	44	32	40	38	67	66	57	49	46	44	41	40
200	40	144	51	32	26	17	15	<	<	15	42	33	29	19	19	<	<	23
	110	393	47	41	34	22	15	<	<	<	55	44	37	28	17	<	<	22
	180	648	50	46	37	30	27	25	22	19	58	49	42	33	28	26	23	26
	280	1008	57	51	45	41	39	37	34	31	29	54	49	43	40	38	36	34
	405	1458	67	61	56	53	51	49	47	45	67	62	57	55	52	51	49	46
250	60	216	42	36	26	20	20	17	15	19	46	40	28	17	21	20	17	21
	170	612	48	39	31	23	20	17	15	15	49	44	37	28	21	19	17	19
	280	1008	51	46	38	34	31	30	27	24	56	51	43	36	33	31	29	28
	470	1692	61	56	51	49	47	45	43	40	62	59	53	50	48	46	44	42
	615	2214	68	64	60	58	56	54	52	50	70	65	61	59	57	55	54	51
315	105	378	41	37	31	19	22	19	17	<	49	38	35	25	19	16	<	22
	265	954	53	47	40	29	22	19	17	25	52	51	45	29	27	24	27	34
	420	1512	54	50	43	35	33	32	29	30	61	58	49	38	36	34	33	37
	720	2592	62	57	52	49	48	46	44	42	66	61	55	50	49	47	45	45
	1025	3690	70	65	61	59	58	56	54	52	73	68	63	60	59	57	56	54
400	170	612	41	38	33	21	22	20	17	<	41	43	37	27	19	16	20	25
	445	1620	51	48	38	28	26	24	23	24	55	53	49	32	29	28	31	35
	710	2556	55	52	43	39	38	36	34	33	59	56	51	41	39	38	37	39
	1250	4500	68	60	56	54	53	51	49	47	70	63	58	55	54	52	50	49
	1680	6048	78	69	65	63	62	60	59	57	79	71	67	64	63	62	60	58

< indicates values below 15

TVZ Air-Regenerated Noise with Reheat Coil with TS secondary silencer

Correction Values

Number of rows (RR)	1RR	2RR	4RR ¹⁾
ΔL in dB	- 2	0	3

Note: ¹⁾ minimum pressure differential as in page 6.

Component layout, in the direction of the air flow, when measuring acoustic data:

TVZ-box, reheat coil, TS attenuator

Air-regenerated noise TVZ with Reheat coil with TS secondary silencer

Nominal size	\dot{V}		$\Delta p_{st} = 200 \text{ Pa}$								$\Delta p_{st} = 500 \text{ Pa}$							
			L_w in dB								L_w in dB							
			f_m in Hz								f_m in Hz							
			63	125	250	500	1000	2000	4000	8000	63	125	250	500	1000	2000	4000	8000
l/s	m ³ /h																	
125	15	54	54	31	17	<	<	<	<	<	55	30	17	<	<	<	<	<
	35	126	56	42	29	<	<	<	<	<	59	40	30	16	<	<	<	<
	60	216	50	46	31	16	<	<	<	<	52	45	35	18	<	<	<	<
	95	342	56	50	38	23	<	<	<	<	57	57	41	25	16	<	<	18
	150	540	60	55	46	34	25	<	<	21	61	59	49	33	24	<	<	23
160	25	90	50	42	21	<	<	<	<	<	52	34	21	<	<	<	<	<
	65	234	49	45	32	<	<	<	<	<	51	46	33	17	<	<	<	<
	100	360	52	50	33	16	<	<	<	<	53	51	37	22	<	<	<	<
	170	612	55	53	44	24	17	<	<	15	57	57	44	27	19	<	<	17
	250	900	63	59	47	34	27	18	<	24	64	63	49	36	29	19	18	26
200	40	144	47	28	<	<	<	<	<	15	38	29	19	<	<	<	<	<
	110	393	43	37	24	15	<	<	<	<	51	40	27	<	<	<	<	<
	180	648	47	42	28	16	<	<	<	<	54	45	32	19	<	<	<	<
	280	1008	53	47	35	26	21	16	<	16	55	50	39	28	22	17	<	18
	405	1458	63	57	46	38	33	27	20	29	63	58	47	40	34	29	21	30
250	60	216	40	31	<	<	<	<	<	15	44	35	16	<	<	<	<	15
	170	612	46	34	19	<	<	<	<	<	47	39	25	<	<	<	<	<
	280	1008	49	41	25	15	<	<	<	<	54	46	30	15	<	<	<	15
	470	1692	59	51	38	25	18	16	16	25	60	54	40	26	18	17	17	27
	615	2214	66	59	47	34	26	25	25	35	68	60	48	35	27	26	26	36
315	105	378	38	33	21	<	<	<	<	<	46	34	25	<	<	<	<	<
	265	954	51	43	30	<	<	<	<	16	49	47	35	<	<	<	<	23
	420	1512	51	46	33	16	<	<	<	20	58	54	39	19	15	<	15	26
	720	2592	59	53	42	29	25	24	25	31	63	57	45	31	26	25	27	34
	1025	3690	67	61	51	39	35	34	35	41	70	64	53	40	36	35	37	43
400	170	612	37	34	25	<	<	<	<	<	37	39	29	<	<	<	<	17
	445	1620	47	44	30	<	<	<	<	17	51	49	41	17	<	15	21	27
	710	2556	51	48	35	24	21	21	23	25	55	52	43	25	23	23	26	31
	1250	4500	64	56	48	38	36	36	38	39	66	59	50	39	37	37	39	41
	1680	6048	74	65	57	47	45	45	48	49	75	67	59	48	46	47	49	50

< indicates values below 15

Case-radiated Noise TVZ

Case-radiated noise calculation procedure

f_m	63	125	250	500	1000	2000	4000	8000
L_{W3} (page 11)	53	49	43	33	25	24	20	23
Ceiling reduction	4	4	4	4	4	4	4	4
Sound power level to room	49	45	39	29	21	20	16	19
Room attenuation	6	6	5	5	4	4	4	4
A-weighting	-26	-16	-9	-3	0	+1	+1	-1
Corrected level	17	23	25	21	17	17	13	14

Sound pressure level of the case-radiated noise $L_{pA3} = 29 \text{ dB(A)}$

Result: Note the above deviates from the room correction on page 7, here other values have been assumed.
The result lies, however, within that required.

Case-radiated noise TVZ without additional acoustic cladding

Nominal size	V		$\Delta p_{st} = 100 \text{ Pa}$								$\Delta p_{st} = 200 \text{ Pa}$								$\Delta p_{st} = 500 \text{ Pa}$							
			L_{W2} in dB								L_{W2} in dB								L_{W2} in dB							
			f_m in Hz								f_m in Hz								f_m in Hz							
			l/s	m ³ /h	63	125	250	500	1000	2000	4000	8000	63	125	250	500	1000	2000	4000	8000	63	125	250	500	1000	2000
125	15	54	<	28	26	26	26	17	15	15	27	31	27	26	27	20	<	<	20	35	28	27	28	25	24	22
	60	216	35	40	33	26	21	17	15	18	38	42	35	30	27	23	16	20	38	46	40	37	34	31	27	25
	105	378	41	45	39	31	25	22	16	16	42	46	40	33	29	26	21	21	46	50	43	40	36	33	29	27
	150	540	45	46	43	37	29	27	18	19	47	49	45	40	34	31	25	25	51	54	46	43	38	34	32	29
160	25	90	22	28	23	25	21	15	15	15	25	28	25	26	24	18	<	16	21	33	28	28	29	28	24	24
	100	360	36	40	35	27	21	19	15	16	39	42	37	31	27	25	19	22	44	46	41	38	35	32	28	29
	175	630	46	42	40	31	23	23	16	22	48	45	42	35	29	28	23	27	49	50	46	42	37	35	32	32
	250	900	48	46	46	38	31	27	22	28	51	49	48	42	35	32	28	32	55	54	51	47	40	36	35	35
200	40	144	30	32	29	28	20	18	15	18	31	32	30	29	25	21	18	22	27	34	34	36	33	30	26	26
	160	576	42	41	37	27	22	21	25	24	46	44	41	33	29	27	27	29	49	48	46	42	37	34	32	33
	280	1008	48	44	43	30	25	25	26	25	51	47	46	36	31	30	28	30	55	52	50	44	39	37	35	37
	405	1458	53	50	51	43	33	32	30	34	56	53	53	46	38	36	35	38	60	56	54	51	43	40	40	42
250	60	216	25	31	29	26	23	15	15	15	28	33	32	30	27	21	<	<	36	36	35	34	33	31	26	23
	250	900	50	42	35	26	20	19	<	15	52	46	40	33	29	26	21	23	53	51	47	42	37	35	32	32
	430	1548	50	47	37	29	21	23	19	19	54	51	44	37	31	30	27	28	58	56	51	44	39	38	36	37
	615	2214	55	50	47	41	28	32	26	28	58	54	51	45	35	36	32	34	62	59	55	50	42	40	40	41
315	100	360	34	36	27	25	22	15	15	15	35	36	31	29	26	20	<	<	40	38	38	37	34	32	28	22
	410	1476	49	42	36	27	21	20	15	15	52	46	42	34	29	27	24	20	56	53	50	45	40	38	36	33
	720	2592	55	47	42	37	26	28	21	24	58	51	47	42	33	33	29	30	61	58	55	48	42	41	40	37
	1025	3690	61	51	49	39	30	35	29	28	64	55	53	44	36	39	35	34	68	62	57	51	43	42	43	39
400	170	612	37	38	32	28	25	20	15	15	40	40	36	33	30	26	19	15	44	42	42	39	37	36	32	22
	671	2416	52	42	37	26	24	25	18	25	56	47	43	35	32	32	27	30	59	56	55	47	41	40	40	31
	1175	4230	62	45	39	29	26	31	23	23	67	52	47	39	34	37	32	30	67	59	55	48	42	42	43	31
	1680	6048	76	60	52	44	32	38	32	32	77	62	55	48	37	41	37	36	79	63	58	51	42	44	46	36

< indicates values below 15

Fan (high pressure) Side Air-regenerated Noise TVZ · TVZD

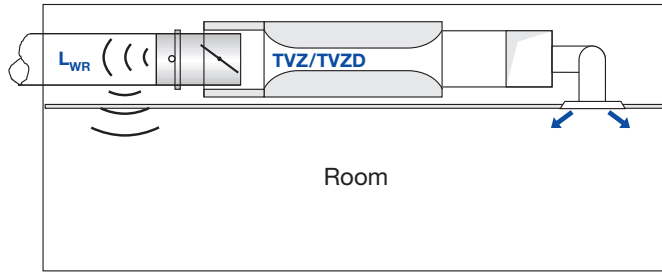

The noise created at the damper is also radiated upstream into the circular high pressure duct.

With the help of the L_{WR} values in the table below, possible effects in the room can be calculated. Further measures may be necessary, for example, additional insulation of the circular ducting and/or greater insulation of the false ceiling.

Fan (high pressure) side air-regenerated noise TVZ

Nominal size	V		$\Delta p_{st} = 100 \text{ Pa}$								$\Delta p_{st} = 200 \text{ Pa}$								$\Delta p_{st} = 500 \text{ Pa}$							
			L_{WR} in dB								L_{WR} in dB								L_{WR} in dB							
			f_m in Hz								f_m in Hz								f_m in Hz							
			63	125	250	500	1000	2000	4000	8000	63	125	250	500	1000	2000	4000	8000	63	125	250	500	1000	2000	4000	8000
125	15	54	72	53	48	46	46	42	27	19	79	55	53	50	46	44	34	27	76	56	50	47	47	51	46	39
	60	216	81	74	65	56	46	44	33	25	84	77	66	58	49	48	41	33	83	76	69	63	57	56	53	45
	105	378	86	82	74	58	48	46	39	33	87	84	75	61	52	51	46	40	90	85	78	68	59	58	55	49
	150	540	91	85	79	69	57	54	45	38	92	86	80	71	60	57	51	45	95	89	84	74	64	61	59	53
160	25	90	65	57	53	52	42	37	30	20	67	61	56	54	43	40	35	27	66	59	54	53	47	49	43	38
	100	360	68	74	66	54	42	40	33	28	71	75	67	57	48	46	41	36	72	76	70	65	56	55	52	47
	175	630	78	79	76	57	45	44	37	33	80	80	77	61	51	50	45	41	85	81	77	69	58	58	56	52
	250	900	87	80	85	69	56	52	46	42	88	82	85	71	60	57	52	48	93	87	88	75	63	61	60	57
200	40	144	53	57	50	48	42	37	28	18	59	62	57	50	45	41	35	27	60	57	53	50	52	50	48	41
	160	576	79	73	63	51	43	43	39	34	80	74	64	54	49	48	45	41	84	77	69	63	57	55	54	50
	280	1008	81	75	70	53	45	48	42	41	84	77	72	58	52	52	49	47	87	80	75	65	59	59	56	55
	405	1458	89	78	80	67	56	56	48	44	90	80	81	69	61	59	54	50	93	84	82	73	64	63	63	61
250	60	216	56	56	50	44	41	36	29	22	59	56	52	45	44	40	35	29	67	57	51	47	52	50	46	39
	250	900	83	71	62	48	41	41	35	31	84	72	64	52	48	47	43	39	85	76	69	61	56	55	55	50
	430	1548	81	65	60	50	45	45	38	31	84	69	65	55	51	50	46	41	91	77	74	64	58	58	58	53
	615	2214	75	57	52	54	54	43	36	26	80	64	60	59	58	49	45	37	95	80	75	68	63	61	61	56
315	100	360	48	53	48	43	42	39	28	20	63	56	50	45	45	42	34	27	54	55	49	49	50	49	45	40
	410	1476	73	67	57	42	39	42	35	31	77	70	60	49	47	48	43	39	86	77	69	64	58	56	55	51
	720	2592	80	70	59	45	44	47	39	35	83	74	64	53	51	52	47	43	87	78	71	64	58	60	59	55
	1025	3690	78	73	66	58	52	52	41	35	83	77	70	63	57	56	49	44	92	82	74	68	61	61	62	57
400	170	612	62	54	50	43	42	40	31	25	69	57	52	46	46	44	38	33	64	54	52	53	53	52	48	43
	671	2416	76	66	54	42	43	46	38	39	78	68	58	50	50	51	46	46	83	73	67	62	57	59	57	55
	1175	4230	80	64	54	42	45	47	41	36	83	68	60	51	51	52	49	45	88	77	68	62	58	61	60	58
	1680	6048	84	60	55	56	56	45	37	28	86	66	61	62	60	51	46	39	93	79	72	66	61	62	63	60

Acoustic Quick Selection TVA · TVAD

System attenuation in dB/oct. acc. to VDI 2081 (taken into account in the quick selection table)

f_m in Hz	63	125	250	500	1000	2000	4000	8000
Duct bend attenuation	0	0	1	2	3	3	3	3
Room attenuation	5	5	5	5	5	5	5	5
End reflection	10	5	2	0	0	0	0	0

Correction for distribution into the low pressure duct system (taken into account in the quick selection table)

\dot{V}	m ³ /h	500	1000	1500	2000	2500	3000	4000	5000	6000
	l/s	139	278	417	556	695	834	1111	1389	1667
dB per octave		0	3	5	6	7	8	9	10	11

Correction for the calculation of the case-radiated noise (taken into account in the quick selection table)

Ceiling reduction in dB/oct.	4
Room attenuation in dB/oct.	5

Quick selection sound pressure level in dB(A)

Nominal size	\dot{V}		$\Delta p_{st} = 100 \text{ Pa}$				$\Delta p_{st} = 200 \text{ Pa}$				$\Delta p_{st} = 500 \text{ Pa}$			
			Air-regenerated noise		Case-radiated noise		Air-regenerated noise		Case-radiated noise		Air-regenerated noise		Case-radiated noise	
			TVA L_{pA}	TVA+TS L_{pA1}	TVA L_{pA2}	TVAD L_{pA3}	TVA L_{pA}	TVA+TS L_{pA1}	TVA L_{pA2}	TVAD L_{pA3}	TVA L_{pA}	TVA+TS L_{pA1}	TVA L_{pA2}	TVAD L_{pA3}
125	15	54	17	16	13	13	19	17	15	13	19	17	21	16
	60	216	23	20	24	22	24	21	27	22	27	23	30	25
	105	378	25	21	28	26	28	24	31	26	35	30	34	29
	150	540	-	-	-	-	27	27	33	28	36	32	37	32
160	25	90	15	14	13	13	17	15	14	13	20	18	20	15
	100	360	27	23	22	20	29	24	26	20	34	29	30	25
	175	630	26	21	27	25	30	25	30	25	37	32	35	29
	250	900	-	-	-	-	26	23	33	28	39	34	39	33
200	40	144	15	14	14	14	17	15	17	14	20	15	19	15
	160	576	21	17	24	21	23	18	26	21	29	20	31	26
	280	1008	22	17	27	26	25	19	31	26	30	23	36	31
	405	1458	-	-	-	-	28	26	32	28	32	28	40	36
250	60	216	15	14	14	13	17	15	14	13	20	15	15	13
	250	900	19	16	25	23	22	17	27	23	27	21	32	28
	430	1548	19	18	27	26	23	22	31	26	30	25	37	32
	615	2214	-	-	-	-	28	29	33	29	32	30	41	36
315	100	360	16	15	14	14	17	15	14	14	18	16	21	16
	410	1476	25	21	26	25	27	22	29	25	31	25	36	31
	720	2592	24	20	32	31	27	24	35	31	33	28	41	36
	1025	3690	-	-	-	-	30	29	39	35	35	31	43	38
400	170	612	15	14	14	14	18	15	19	14	21	16	28	22
	671	2416	17	13	29	28	21	16	33	28	28	23	39	33
	1175	4230	22	19	35	34	27	23	39	34	32	27	44	39
	1680	6048	-	-	-	-	34	31	44	40	36	32	47	43

For acoustic data for differential pressure up to 1000 Pa, refer to TROX EASY PRODUCT FINDER

Air-regenerated Noise TVA · TVAD

without TS secondary silencer

Insertion loss								
Type / nominal size	D _e in dB							
	f _m in Hz							
	63	125	250	500	1000	2000	4000	8000
TVA 125 to 400 without TS	15	21	27	35	41	39	32	23
TVA 125 to 400 with TS	18	30	35	48	48	46	40	33

Air-regenerated noise TVA without TS secondary silencer																											
Nominal size	V̇		Δ p _{st} = 100 Pa								Δ p _{st} = 200 Pa								Δ p _{st} = 500 Pa								
			L _w in dB								L _w in dB								L _w in dB								
			f _m in Hz								f _m in Hz								f _m in Hz								
			63	125	250	500	1000	2000	4000	8000	63	125	250	500	1000	2000	4000	8000	63	125	250	500	1000	2000	4000	8000	
l/s	m ³ /h																										
		125	15	54	50	35	26	15	15	15	15	17	51	39	30	17	<	<	<	20	54	39	27	<	<	<	<
60	216		49	47	33	15	15	15	15	15	56	48	35	18	<	<	<	<	54	50	39	25	17	<	<	21	
105	378		51	48	38	21	15	15	15	16	57	51	41	25	16	<	<	20	56	58	48	31	21	16	16	25	
150	540		-	-	-	-	-	-	-	-	59	49	39	28	25	18	<	22	60	59	49	36	26	21	20	30	
160	25	90	43	29	24	15	15	15	15	15	42	30	28	17	<	<	<	18	57	38	26	<	<	<	16	18	
	100	360	42	51	38	21	15	15	15	15	43	53	41	26	<	<	<	18	45	57	47	33	18	<	15	22	
	175	630	43	50	41	22	15	15	15	17	45	54	45	28	17	<	17	23	49	61	51	37	24	18	22	32	
	250	900	-	-	-	-	-	-	-	-	46	49	41	31	26	19	16	21	56	65	51	42	30	24	26	37	
200	40	144	42	24	18	15	15	15	15	15	48	29	23	20	<	<	<	17	46	33	26	22	19	17	18	24	
	160	576	49	46	29	19	15	15	15	17	51	46	32	23	19	18	18	23	56	47	36	29	24	23	25	35	
	280	1008	53	43	35	23	22	21	19	28	55	46	38	27	25	23	23	31	60	53	44	32	28	27	27	37	
	405	1458	-	-	-	-	-	-	-	-	53	44	38	35	35	32	28	32	64	53	46	39	37	34	32	38	
250	60	216	42	24	20	15	15	15	15	17	47	29	24	19	15	<	15	21	46	31	28	23	19	18	19	24	
	250	900	51	45	29	21	16	16	16	19	53	47	33	25	20	20	20	24	56	51	40	31	24	24	25	29	
	430	1548	47	42	30	27	26	22	18	21	51	47	36	31	28	25	23	27	61	56	45	37	32	29	31	35	
	615	2214	-	-	-	-	-	-	-	-	55	45	44	38	34	35	31	33	62	56	47	41	36	37	35	38	
315	100	360	43	35	25	15	15	15	15	15	45	37	26	<	<	<	<	17	49	39	28	15	<	<	<	<	
	410	1476	56	54	38	24	20	17	20	31	59	55	41	29	25	21	25	33	65	58	45	36	29	25	32	33	
	720	2592	57	51	41	31	33	22	24	30	61	55	45	36	31	26	30	35	71	61	50	41	35	29	40	39	
	1025	3690	-	-	-	-	-	-	-	-	65	49	42	43	40	36	36	38	72	61	52	47	42	37	45	44	
400	170	612	43	35	22	15	15	15	15	17	45	37	25	18	16	<	16	22	47	38	30	23	20	19	21	26	
	671	2416	52	44	30	21	20	20	22	27	55	48	35	26	24	24	27	32	61	54	42	31	29	28	36	38	
	1175	4230	68	47	36	30	30	29	27	32	70	52	41	35	34	33	34	38	70	58	47	37	35	34	43	44	
	1680	6048	-	-	-	-	-	-	-	-	80	62	47	44	41	42	43	47	80	63	50	45	42	42	47	49	

< indicates values below 15

Air-regenerated Noise TVA · TVAD

with TS secondary silencer

Air-regenerated noise TVA with TS secondary silencer

Nominal size	\dot{V}		$\Delta p_{st} = 100 \text{ Pa}$								$\Delta p_{st} = 200 \text{ Pa}$								$\Delta p_{st} = 500 \text{ Pa}$							
			L_{W1} in dB								L_{W1} in dB								L_{W1} in dB							
			f_m in Hz								f_m in Hz								f_m in Hz							
			63	125	250	500	1000	2000	4000	8000	63	125	250	500	1000	2000	4000	8000	63	125	250	500	1000	2000	4000	8000
I/s	m ³ /h																									
125	15	54	46	32	22	15	15	15	15	15	49	35	25	<	<	<	<	<	52	35	23	<	<	<	<	<
	60	216	50	43	28	15	15	15	15	15	54	44	30	16	<	<	<	<	52	46	34	16	<	<	<	15
	105	378	48	44	33	19	15	15	15	15	55	47	36	22	17	<	<	<	54	54	43	22	17	<	<	18
	150	540	-	-	-	-	-	-	-	-	57	45	36	32	29	22	<	15	58	55	44	32	29	22	15	22
160	25	90	32	26	18	15	15	15	15	15	40	27	22	<	<	<	<	<	55	34	20	<	<	<	<	<
	100	360	40	47	31	15	15	15	15	15	41	49	34	15	<	<	<	<	43	53	40	19	<	<	<	17
	175	630	41	46	34	18	15	15	15	15	43	50	38	21	<	<	<	18	47	57	44	24	15	<	<	26
	250	900	-	-	-	-	-	-	-	-	44	45	36	31	26	19	<	16	54	61	44	32	27	20	<	31
200	40	144	40	21	15	15	15	15	15	15	46	26	17	<	<	<	<	<	44	29	19	<	<	<	<	<
	160	576	47	41	22	15	15	15	15	15	49	42	25	15	<	<	<	<	54	43	28	19	<	<	<	21
	280	1008	51	39	30	25	17	15	15	16	53	42	32	26	20	<	<	18	58	49	37	27	20	<	<	23
	405	1458	-	-	-	-	-	-	-	-	51	42	38	38	33	27	18	19	62	49	41	38	34	27	18	24
250	60	216	38	20	15	15	15	15	15	15	45	25	16	<	<	<	<	15	44	27	19	<	<	<	<	17
	250	900	49	42	22	16	15	15	15	15	51	43	25	18	<	<	<	17	54	47	30	20	<	<	<	21
	430	1548	45	38	32	28	22	19	15	15	49	43	35	33	28	21	<	20	59	52	38	33	28	21	17	27
	615	2214	-	-	-	-	-	-	-	-	53	44	43	42	38	32	24	25	60	52	43	42	38	32	25	30
315	100	360	41	31	17	15	15	15	15	15	43	33	18	<	<	<	<	<	47	35	20	<	<	<	<	<
	410	1476	54	50	30	17	15	15	15	25	57	51	33	21	16	<	15	27	63	54	36	25	18	<	21	27
	720	2592	55	47	36	31	29	22	15	24	59	51	39	35	30	23	20	29	69	57	42	35	31	24	29	33
	1025	3690	-	-	-	-	-	-	-	-	63	47	45	44	41	36	29	32	70	57	47	45	41	36	35	38
400	170	612	41	31	15	15	15	15	15	15	43	33	17	<	<	<	<	19	45	34	21	15	<	<	15	22
	671	2416	50	40	24	17	15	15	15	23	53	44	28	20	15	15	20	28	59	50	33	23	20	19	29	34
	1175	4230	65	43	34	30	27	16	20	28	68	48	38	34	29	25	27	34	68	54	40	34	30	25	36	40
	1680	6048	-	-	-	-	-	-	-	-	78	58	45	43	39	35	36	43	78	59	46	43	39	35	40	45

< indicates values below 15

Case-radiated Noise TVA

Case-radiated noise TVA without additional acoustic cladding

Nominal size	V		$\Delta p_{st} = 100 \text{ Pa}$								$\Delta p_{st} = 200 \text{ Pa}$								$\Delta p_{st} = 500 \text{ Pa}$							
			L_{W2} in dB								L_{W2} in dB								L_{W2} in dB							
			f_m in Hz								f_m in Hz								f_m in Hz							
			63	125	250	500	1000	2000	4000	8000	63	125	250	500	1000	2000	4000	8000	63	125	250	500	1000	2000	4000	8000
125	15	54	15	22	15	16	15	15	15	<	26	18	<	<	19	<	20	27	24	24	23	23	23	22	25	
	60	216	29	40	34	27	22	24	23	26	34	41	35	30	26	28	27	30	42	45	37	32	29	33	30	32
	105	378	37	43	39	32	26	28	27	28	40	45	40	35	29	32	31	32	45	50	42	35	32	36	33	34
	150	540	-	-	-	-	-	-	-	-	45	48	43	40	32	34	31	33	48	53	46	41	35	38	38	37
160	25	90	17	24	16	15	15	15	15	23	29	20	15	<	15	<	19	24	28	22	20	20	22	20	24	
	100	360	40	42	31	25	20	23	21	22	42	43	34	28	24	27	25	27	42	45	37	31	29	32	30	31
	175	630	45	45	35	30	25	27	25	29	47	47	38	33	28	31	29	32	49	51	42	37	33	36	34	36
	250	900	-	-	-	-	-	-	-	-	48	50	42	38	32	33	32	34	55	56	47	42	36	39	39	40
200	40	144	26	31	22	15	15	15	15	15	32	34	24	18	17	19	16	20	22	31	25	22	20	21	19	23
	160	576	46	45	30	23	21	24	21	19	47	46	34	28	26	28	26	26	51	48	39	33	30	32	32	34
	280	1008	45	44	36	28	25	29	26	29	48	48	39	32	29	32	31	33	55	52	45	37	34	36	38	38
	405	1458	-	-	-	-	-	-	-	-	48	46	42	39	32	33	31	32	61	53	48	44	38	39	44	43
250	60	216	23	32	15	15	15	15	15	15	25	32	<	<	<	<	<	32	33	<	<	18	18	<	<	
	250	900	48	47	29	21	<	26	19	26	50	48	33	27	16	30	25	30	56	52	39	34	31	34	33	33
	430	1548	46	45	29	25	26	32	24	26	50	48	38	33	31	34	29	31	59	55	45	41	37	38	39	37
	615	2214	-	-	-	-	-	-	-	-	50	45	47	40	32	32	26	29	59	56	50	44	41	41	43	40
315	100	360	27	31	16	15	15	16	15	16	28	31	15	16	15	15	<	15	39	34	19	18	24	25	20	20
	410	1476	52	42	29	24	24	29	23	27	54	44	34	30	29	33	28	31	55	48	43	38	35	38	38	37
	720	2592	58	48	37	31	31	34	30	33	60	50	42	36	35	38	34	37	60	53	48	42	40	42	44	42
	1025	3690	-	-	-	-	-	-	-	-	64	54	48	43	38	40	37	39	62	55	52	46	43	44	45	44
400	170	612	29	28	15	15	15	15	15	15	32	30	20	20	22	22	19	18	44	35	30	26	28	32	29	28
	671	2416	47	37	29	26	28	34	31	29	50	42	36	33	33	38	36	34	56	49	46	39	37	40	43	40
	1175	4230	60	46	42	34	33	37	36	38	63	50	47	40	38	41	41	42	64	52	49	44	43	45	49	47
	1680	6048	-	-	-	-	-	-	-	-	71	58	50	47	44	42	43	46	72	58	53	48	46	47	51	50

< indicates values below 15

Case-radiated Noise TVAD

Case-radiated noise TVAD with additional acoustic cladding

Nominal size	V̇		$\Delta p_{st} = 100 \text{ Pa}$								$\Delta p_{st} = 200 \text{ Pa}$								$\Delta p_{st} = 500 \text{ Pa}$							
			L_{W3} in dB								L_{W3} in dB								L_{W3} in dB							
			f_m in Hz								f_m in Hz								f_m in Hz							
			63	125	250	500	1000	2000	4000	8000	63	125	250	500	1000	2000	4000	8000	63	125	250	500	1000	2000	4000	8000
I/s	m ³ /h																									
125	15	54	<	19	<	15	15	15	15	15	<	20	<	<	<	<	15	24	18	18	16	19	18	17	20	
	60	216	31	35	29	23	22	23	22	25	31	35	29	23	22	23	25	39	39	31	25	25	28	25	27	
	105	378	38	40	35	29	26	27	26	27	37	39	34	28	25	27	26	27	42	44	36	28	28	31	28	29
	150	540	-	-	-	-	-	-	-	-	42	42	37	33	28	29	26	28	45	47	40	34	31	33	33	32
160	25	90	21	23	15	15	15	15	15	15	21	23	15	<	<	<	<	<	22	22	17	<	16	17	15	19
	100	360	40	37	29	22	20	22	20	22	40	37	29	22	20	22	20	22	40	39	32	25	25	27	25	26
	175	630	45	41	33	27	24	26	24	27	45	41	33	27	24	26	24	27	47	45	37	31	29	31	29	31
	250	900	-	-	-	-	-	-	-	-	46	44	37	32	28	28	27	29	53	50	42	36	32	34	34	35
200	40	144	30	29	20	15	15	15	15	15	30	29	20	<	<	<	<	15	20	26	21	17	16	16	<	18
	160	576	45	41	29	22	21	22	20	20	45	41	30	23	22	23	21	21	49	43	35	28	26	27	27	29
	280	1008	46	43	35	27	25	27	26	28	46	43	35	27	25	27	26	28	53	47	41	32	30	31	33	33
	405	1458	-	-	-	-	-	-	-	-	46	41	38	34	28	28	26	27	59	48	44	39	34	34	39	38
250	60	216	22	26	15	15	15	15	15	15	23	27	<	<	<	<	<	<	38	28	<	<	<	<	<	<
	250	900	48	43	28	21	<	24	19	25	48	43	29	22	<	25	20	25	54	47	35	29	27	29	28	28
	430	1548	48	44	32	26	27	30	25	27	48	43	34	28	27	29	24	26	57	50	41	36	33	33	34	32
	615	2214	-	-	-	-	-	-	-	-	48	40	43	35	28	27	21	24	57	51	46	39	37	36	38	35
315	100	360	28	27	15	15	15	15	15	15	27	27	<	<	<	<	<	<	38	30	15	<	20	19	<	15
	410	1476	53	40	30	25	25	27	22	26	53	40	30	25	25	27	22	26	54	44	39	33	31	32	32	32
	720	2592	59	46	38	31	31	32	28	32	59	46	38	31	31	32	28	32	59	49	44	37	36	36	38	37
	1025	3690	-	-	-	-	-	-	-	-	63	50	44	38	34	34	31	34	61	51	48	41	39	38	39	39
400	170	612	31	26	16	15	18	15	15	15	31	26	16	15	18	15	<	<	43	31	26	21	24	25	23	23
	671	2416	48	37	31	27	29	31	30	28	49	38	32	28	29	31	30	29	55	45	42	34	33	33	37	35
	1175	4230	61	45	42	34	33	34	35	36	62	46	43	35	34	34	35	37	63	48	45	39	39	38	43	42
	1680	6048	-	-	-	-	-	-	-	-	70	54	46	42	40	35	37	41	71	54	49	43	42	40	45	45

< indicates values below 15

Fan (high pressure) Side Air-regenerated Noise TVA · TVAD

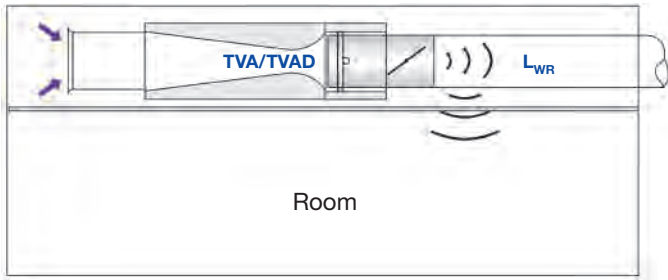

The noise created at the damper is also radiated upstream into the circular high pressure duct.

With the help of the L_{WR} values in the table below, possible effects in the room can be calculated. Further measures may be necessary, for example, additional insulation on the circular ducting and/or greater insulation of the false ceiling.

Fan (high pressure) side air-regenerated noise TVA

Nominal size	V		$\Delta p_{st} = 100 \text{ Pa}$										$\Delta p_{st} = 200 \text{ Pa}$								$\Delta p_{st} = 500 \text{ Pa}$							
			L_{WR} in dB										L_{WR} in dB								L_{WR} in dB							
			f_m in Hz										f_m in Hz								f_m in Hz							
			63	125	250	500	1000	2000	4000	8000	63	125	250	500	1000	2000	4000	8000	63	125	250	500	1000	2000	4000	8000		
125	15	54	74	48	45	34	24	25	21	13	76	56	47	36	29	30	27	22	75	50	47	38	33	33	36	34		
	60	216	84	76	61	49	44	44	40	32	86	77	65	53	48	48	45	38	90	79	69	59	54	53	52	47		
	105	378	88	78	73	55	48	48	47	38	90	80	75	59	53	52	52	45	94	85	77	65	60	58	60	55		
	150	540	-	-	-	-	-	-	-	-	87	80	73	64	55	50	53	44	97	89	81	72	66	60	65	59		
160	25	90	60	43	44	31	22	19	14	10	66	48	48	36	27	25	22	19	72	54	51	40	33	32	31	29		
	100	360	73	75	62	51	42	51	48	42	78	77	66	56	48	54	52	46	89	80	72	64	55	57	58	54		
	175	630	82	75	69	54	47	53	55	46	86	79	73	59	53	56	59	52	93	84	77	68	59	61	65	61		
	250	900	-	-	-	-	-	-	-	-	77	76	70	61	58	54	56	48	98	88	79	73	65	62	68	66		
200	40	144	57	59	48	40	30	22	16	8	62	60	50	43	35	29	24	18	78	63	55	49	44	39	36	34		
	160	576	80	69	56	51	44	52	48	44	81	72	60	54	49	54	50	46	84	78	66	61	58	59	54	51		
	280	1008	83	71	59	55	46	58	55	50	85	75	64	59	52	60	58	54	89	81	70	65	60	63	63	61		
	405	1458	-	-	-	-	-	-	-	-	84	74	68	64	57	57	55	51	97	83	74	71	64	66	68	68		
250	60	216	68	49	40	34	34	30	24	14	74	56	47	40	39	37	30	23	72	51	44	38	35	34	34	33		
	250	900	82	73	56	51	49	57	48	46	84	74	60	55	53	59	53	50	86	77	66	62	57	62	61	58		
	430	1548	84	69	58	55	49	60	52	49	87	74	64	61	55	63	59	56	92	81	74	68	62	66	69	65		
	615	2214	-	-	-	-	-	-	-	-	89	76	69	68	61	65	62	59	97	84	75	74	66	68	74	70		
315	100	360	50	55	46	41	37	35	32	23	58	56	47	42	43	42	36	30	57	57	48	43	40	38	38	36		
	410	1476	80	66	50	51	52	59	51	48	82	70	58	56	56	61	56	53	86	76	57	64	60	63	65	61		
	720	2592	80	68	57	56	51	64	56	51	84	73	63	62	57	66	62	58	91	81	71	69	64	68	74	68		
	1025	3690	-	-	-	-	-	-	-	-	88	75	67	71	61	68	65	61	96	83	74	74	67	70	79	72		
400	170	612	66	54	47	39	37	35	29	22	71	55	49	42	41	39	35	30	69	57	53	47	44	42	42	40		
	671	2416	79	60	56	51	52	57	58	54	82	65	61	56	56	59	61	58	85	72	68	63	60	63	66	64		
	1175	4230	85	64	61	55	53	60	63	58	88	69	67	61	58	63	67	64	92	77	74	68	65	68	73	73		
	1680	6048	-	-	-	-	-	-	-	-	96	75	73	39	63	67	71	70	98	80	78	73	68	69	76	77		

Control code BC0 – Compact flow rate controller

Flow rate ranges								
Nominal size	in l/s				in m ³ /h			
	\dot{V}_{\min}		\dot{V}_{\max}		\dot{V}_{\min}		\dot{V}_{\max}	
	$\dot{V}_{\min \text{ unit}}^1$	up to	from	up to \dot{V}_{Nom}	$\dot{V}_{\min \text{ unit}}^1$	up to	from	up to \dot{V}_{Nom}
	TVZ · TVA							
125	15	150	45	150	54	540	162	540
160	25	250	75	250	90	900	270	900
200	40	405	120	405	144	1458	432	1458
250	60	615	185	615	216	2214	666	2214
315	105	1025	310	1025	378	3690	1116	3690
400	170	1680	505	1680	612	6048	1818	6048

¹⁾ $V_{\min} = 0$ is also possible

Wiring

The 24 V supply voltage must be derived from a safety transformer to (EN 60742). It is important to ensure that the common neutral or ground wire is used is not connected to any other wiring.

VAV Compact

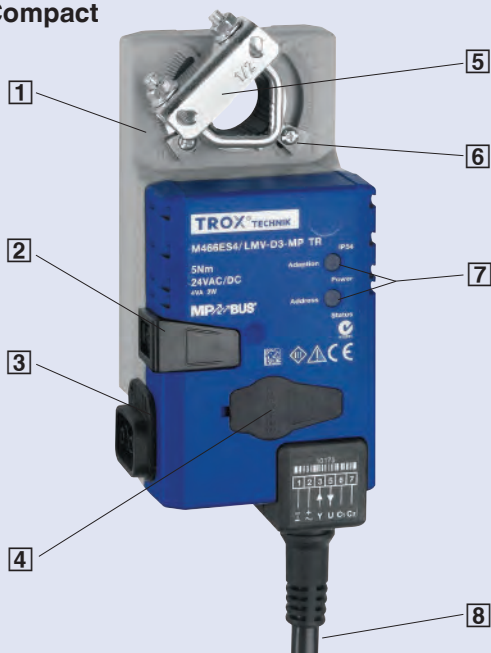

- 1 VAV Compact
- 2 Gear release button
- 3 Tube connection for transducer
- 4 Connection for adjustment tool
- 5 Shaft clamp
- 6 Rotation angle limiter
- 7 Indicator lights
- 8 Connecting cable

Terminal allocation

⊥	~	w	U5 / MP
○	○	○	○
1	2	3	5

VAV Compact

Nomenclature

- ⊥ Ground
- ~ Supply voltage 24 V
- w Control signal input (0/2 to 10 V DC)
- MP MP bus
- U5 Actual value signal output (output signal is volumetric flow 0-10 V)

Technical data

Supply voltage	24 V AC ± 20 %, 50/60 Hz. 24 V DC		
Power rating	max. 4 VA (for AC voltage) max. 2 W (for DC voltage)	IEC protection class	III (Safe voltage)
Control signal	0 to 10 V DC, $R_i > 100 \text{ k}\Omega$	Protection level	IP 54
Flow rate actual value signal	0 to 10 V DC linear, max. 0,5 mA	EMC	CE marking according to 89/336/EWG

Room temperature controller

System solution for decentralised room temperature control
The individual room control, together with the air terminal unit and its control components, form a functional package for optimum control of the individual room temperature with the lowest energy use.

Two unit options are available with various output sequences suitable for a range of applications including air-water systems.

Functions

Comfort mode

The comfort setpoint values (heating/cooling) are maintained
All control functions are enabled.

Power cut-off

The controller cuts off the control functions and only allows protection modes i.e. for frost. This function is usually active when a window is open.

Standby

The room is maintained in a state from which the comfort setpoint values can be quickly reached again. Thus, the cooling setpoint value is raised and the heating setpoint value lowered.

Change over

A function required when the air conditioning system is operated with warm or cold air, the direction of control is reversed depending on the time of year.

Room temperature controller



Control diagram with heating and cooling modes

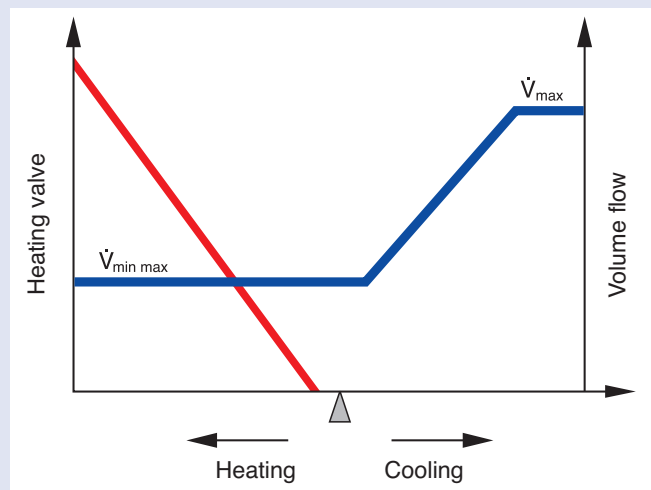

CR24-B2

Individual room controller with two outputs for VAV systems and hot-water heating (reheat unit or radiators).

CR24-B3

Individual room controller with three outputs for VAV systems and additional heating and cooling functions.

Electric Heaters 1)

The electric heater is available as an integral unit complete with controls including fuses and interlocks.

The integral air heater has elements designed for black heat operation and consists of 80 / 20 nickel chrome wire in a stainless steel tube (grade 312) filled with magnesium oxide.

An automatic reset high temperature cut out is fitted and a brass earth stud included. The heater is manufactured to British Standards /Codes as applicable and fully factory tested. A low air pressure switch is fitted. This switch will disconnect the heater if the airflow reduces below a pre-set minimum.

The heater elements are wired back into the control enclosure, including the earth where heater fuses are supplied.

Control of the heater can be arranged for stepless control by thyristors. Control type should be selected to suit the temperature controller used and the degree of accuracy required on temperature control.

¹⁾ Electric heaters are available on request. Full details required such as kW, Voltage, Phase should be stated.

Standard Electric Heaters

Standard electric heaters										
Size	Volts	Phase	1kW	2kW	3kW	4kW	5kW			Minimum Airflow
125	230	1								50 l/s
160	230	1								85 l/s
200	230	1								140 l/s
250	230	1								210 l/s
315	230	1								375 l/s
400	230	1								580 l/s
Size	Volts	Phase			3kW	4.5kW		6kW	7.5kW	9kW
160	400	3								85 l/s
200	400	3								140 l/s
250	400	3								210 l/s
315	400	3								375 l/s
400	400	3								580 l/s

Note ¹⁾ All the above heaters are one step for use with a thyristor.

²⁾ Heaters should be sized such that the maximum air off temperature is approx 30 C

Reheat Coil Selection

1 Mean water pressure drop for sizes 125 to 400

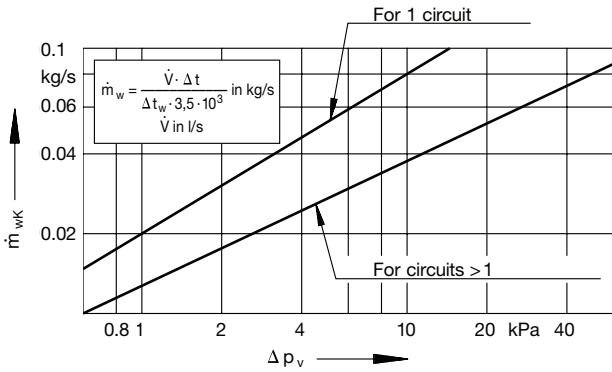

Water Pressure Drop Calculation

One, two or four row reheat coil

$$\dot{m}_{wK} = \frac{\dot{m}_w}{K} \text{ in kg/s}$$

		Number of rows					
Size		125	160	200	260	315	400
K	1RR	1	1	2	2	2	4
	2RR	1	2	4	4	5	7
	4RR	1	2	4	4	5	9

2 Selection diagram

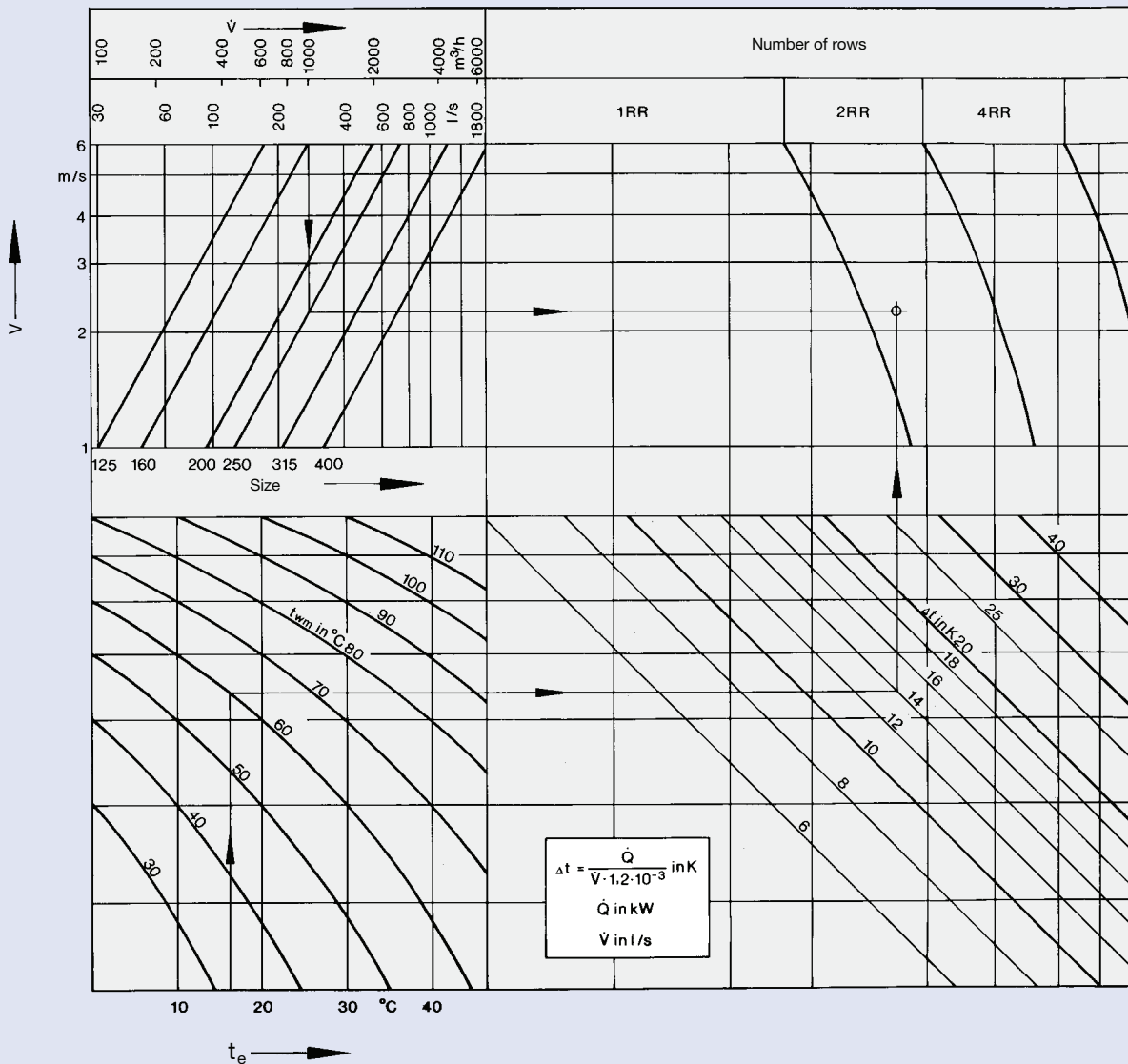

See page 6 for Nomenclature

Specification Text

VAV terminal boxes for variable volume systems, for supply air, in 6 nominal sizes.

Ready-to-use box consisting of mechanical parts and electronic control components. The boxes contain an averaging differential pressure sensor for volume flow measurement, a control damper and an integral silencer.

Special characteristics:

- Integral sound attenuator with at least 26 dB insertion loss at 250 Hz
- Factory set up or programming of flow rate. This includes aerodynamic function test of each box using a dedicated test rig.

Differential pressure sensor with 3 mm measuring holes and so insensitive to dirt.

Control closed damper blade airtightness to EN 1751, class 4 (nominal size 125, class 3). Position of the control damper blade visible from the outside on the shaft extension.

Baffle plates are fitted behind the control damper for optimum acoustic and aerodynamic qualities. Casing with acoustic and thermal lining.

Variable flow rate control with electronic controller for the connection of an external control signal, actual value signal for incorporation in the central control in a building (BMS).

24 VAC power supply DC

Signal voltage: 0 to 10 VDC

Dynamic differential pressure measurement

On site measurement and resetting of minimum and maximum air flow rates possible.

The actual value signal is referred to the nominal flow rate so simplifying any subsequent adjustment to volume flow.

Flow rate range (depending on manufacturer and type of controller) approx. 10 % to 100% of nominal flow rate.

Differential pressure range 20 to 1500 Pa

Circular spigot on the fan (high pressure) side, this includes a groove for the use of a lip seal, suitable for circular connecting ducts to EN 1506 or EN 13180. Room (low pressure) side suitable for attachment of connecting flanges.

Casing air leakage complies with EN 1751, class A with VDI 2083, clean room class 3 and US Federal Standard 209E.

Materials:

Lining in the sound attenuator section and in the control damper chamber from mineral wool conforming to DIN 4102, fire rating class A2. See page 5.

Mineral wool faced with fibreglass as protection against erosion suitable for air velocities up to 20 m/s, inert to fungal and bacterial growth.

Control damper blade with thermoplastic elastomer seal, sensor tubes in aluminium, plastic plain bearings.

Options:

Additional acoustic cladding for the reduction of case-radiated noise with structure-borne noise isolation, insulation of minimum 5 dB, consists of 40 mm mineral wool and outer cover consisting of 1 mm galvanised sheet steel, non-retrofitable.

Reheat Coil, or electric heater battery. See pages 5 and 23 respectively.

TS secondary silencer, for the reduction of air-regenerated noise, entire insertion loss of the basic unit with TS at least 32 dB at 250 Hz. Lining of mineral wool conforming to DIN 4102, fire rating class A2.

Mineral wool faced with fibreglass as protection against erosion, suitable for air velocities up to 20 m/s, inert to fungal and bacterial growth.

Order Code TVZ

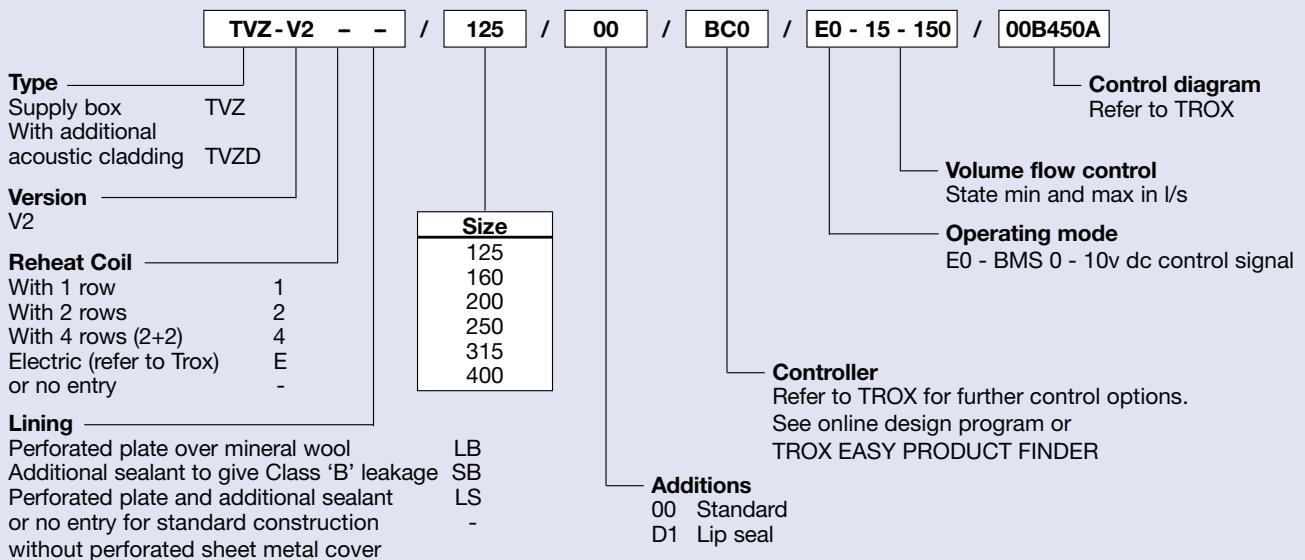

Order Details TS

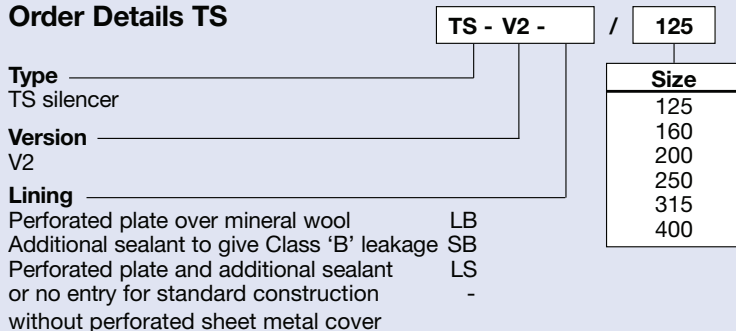

Order Example TVZ

Make: TROX
Type: TVZ-V2/125/00/BC0/E0-15-150/00B450

Order Example TS

Make: TROX
Type: TS-V2/125

Order Details TVA · TS

extract box

Specification Text

VAV terminal boxes for variable volume systems, for extract air, in 6 nominal sizes.

Ready-to-use box consisting of mechanical parts and electronic control components. The boxes contain an averaging differential pressure sensor for volume flow measurement, a control damper and an integral silencer.

Special characteristics:

- Integral sound attenuator with at least 26 dB insertion loss at 250 Hz
- Factory set up or programming of flow rate. This includes aerodynamic function test of each box using a dedicated test rig.

Differential pressure sensor with 3 mm measuring holes and so insensitive to dirt.

Control closed damper blade airtightness to EN 1751, class 4 (nominal size 125, class 3). Position of the control damper blade visible from the outside on the shaft extension.

Baffle plates are fitted behind the control damper for optimum acoustic and aerodynamic qualities. Casing with acoustic and thermal lining.

Variable flow rate control with electronic controller for the connection of an external control signal, actual value signal for incorporation in the central control in a building (BMS).

24 VAC power supply

Signal voltage: 0 to 10 VDC

Dynamic differential pressure measurement

On site measurement and resetting of minimum and maximum air flow rates possible.

The actual value signal is referred to the nominal flow rate so simplifying any subsequent adjustment to volume flow.

Flow rate range (depending on manufacturer and type of controller) approx. 10 % to 100% of nominal flow rate.

Differential pressure range 20 to 1500 Pa

Circular spigot on the fan (high pressure) side, this includes a groove for the use of a lip seal, suitable for circular connecting ducts to EN 1506 or EN 13180. Room (low pressure) side suitable for attachment of connecting flanges. Casing air leakage complies with EN 1751, class A.

Materials:

Lining in the sound attenuator section and in the control damper chamber from mineral wool conforming to EN 4102, fire rating class A2.

Mineral wool faced with fibreglass as protection against erosion suitable for air velocities up to 20 m/s, inert to fungal and bacterial growth.

Control damper blade with thermoplastic elastomer seal, sensor tubes in aluminium, plastic plain bearings.

Options:

Additional acoustic cladding for the reduction of case-radiated noise with structure-borne noise isolation, insulation of minimum 5 dB, consists of 40 mm mineral wool and outer cover consisting of 1 mm galvanised sheet steel, non-retrofitable.

TS secondary silencer, for the reduction of air-regenerated noise, entire insertion loss of the basic unit with TS at least 32 dB at 250 Hz. Lining of mineral wool conforming to EN 4102, fire rating class A2.

Mineral wool faced with fibreglass as protection against erosion, suitable for air velocities up to 20 m/s, inert to fungal and bacterial growth.

Order Code TVA

TVA-V2 - / 125 / 00 / BC0 / E0-15-150 / 00B450B

Type

Extract box TVA
With additional acoustic cladding TVAD

Version

V2

Lining

Perforated plate over mineral wool LB
Additional sealant to give Class 'B' leakage SB
Perforated plate and additional sealant LS
or no entry for standard construction -
without perforated sheet metal cover

Size

125
160
200
250
315
400

Control diagram

Refer to TROX

Volume flow control

State min and max in l/s

Operating mode

E0 - BMS 0 - 10v dc control signal

Controller

Refer to TROX for further control options.

See online design program or
TROX EASY PRODUCT FINDER

Additions

00 Standard
D1 Lip seal

Order Details TS

TS-V2 - / 125

Type

TS silencer

Version

V2

Lining

Perforated plate over mineral wool LB
Additional sealant to give Class 'B' leakage SB
Perforated plate and additional sealant LS
or no entry for standard construction -
without perforated sheet metal cover

Size

125
160
200
250
315
400

Order Example TVA

Make: TROX
Type: TVA-V2/125/00/BC0/E0-15-150/00B450

Order Example TS

Make: TROX
Type: TS-V2/125