

# VARYCONTROL VAV Terminal Unit

for Variable Volume Systems  
Type TVS

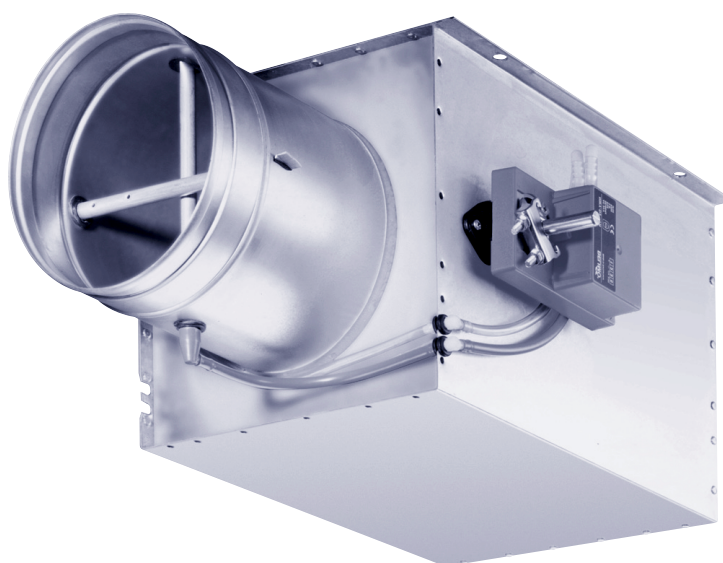

**TROX<sup>®</sup> TECHNIK**

Trox (U.K.) Ltd  
Caxton Way  
GB-Thetford  
Norfolk IP24 3SQ

Telephone +44 (0)1842 754545  
Telefax +44 (0)1842 763051  
[www.troxuk.co.uk](http://www.troxuk.co.uk)  
e-mail: [trox@troxuk.co.uk](mailto:trox@troxuk.co.uk)

# Contents · Description

Description _____	2	Regenerated Noise TVS-A _____	6
Construction and Dimensions _____	3	Regenerated Noise TVS-B _____	7
Air Volume Control _____	4	Case Radiated Noise TVS-A _____	8
Supply Duct Connection _____	4	Case Radiated Noise TVS-B _____	9
Nomenclature _____	5	Reheat Coil Selection _____	10
Aerodynamic Data _____	5	Order Details _____	11

VAV Unit Type TVS-A

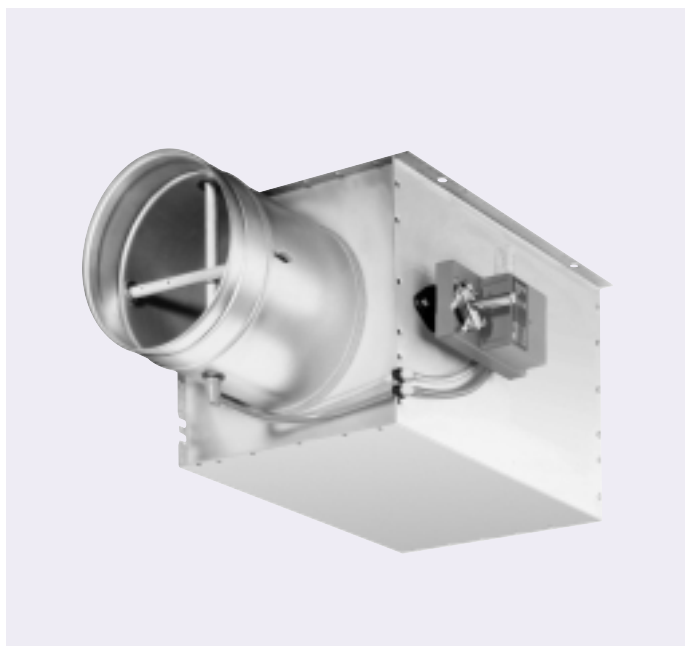

Trox Varycontrol VAV units Type TVS are volume flowrate controllers for supply air on variable volume systems.

They consist of a casing with circular inlet spigot and rectangular outlet connection, integral attenuator for the reduction of regenerated noise, damper blade and averaging differential pressure grid for monitoring the volume flowrate. The damper blade with plastic seal is air tight to DIN 1946 in the closed position.

Because the casing can be supplied in alternative lengths the unit can be selected to meet the specification requirements.

The attenuator length is short in construction and therefore the units are especially suitable for systems with less stringent acoustic requirements and limited space. The TVS unit can be supplied with two or four row reheat coils, if required.

VAV Unit Type TVS-B



The unit also incorporates the control components, (velocity controller, transducer. Actuator) which are factory fitted, wired and tubed. Each VAV unit is aerodynamically tested at the factory and set to the required volume flowrates.

Further information on application and selection and the control components available is contained in Product Information leaflet "Varycontrol VAV Units".

# Construction · Dimensions

## Construction

### Casing

- Circular inlet spigot suitable for ducts to DIN 24 145 or DIN 24 146 with groove for lip seal  
(Lip seal can be factory fitted or site fitted by others)
- Suitable for slide on flange on discharge end
- Suspension points in edge of casing for support rods
- Leakage flow rate to Class II, VDI 3803 or DIN V 24 194, Part 2
- Conforms with clean room Class 3 VDI 2083 and Class 100 US Standard 209b

### Volume Control

- Electronic volume flowrate controller
- Suitable for supply air
- Volume flow range approx. 10:1 depending on type of controller
- High accuracy of control because of averaging differential pressure grid, even with unfavourable duct connections (see page 4)
- Differential pressure range 20 to 1500 Pa
- Full shut-off of damper blade facility
- Damper blade leakage to DIN 1946, Part 4
- Operation independent of mounting position

- Factory volume setting and aerodynamic testing of each unit
- Maintenance free damper blade mechanism
- Volume flowrate can be measured and adjusted
- Operating temperature 10 to 50°C

### Re-heat Coil

- For terminal reheat of primary air
- Casing from galvanised sheet steel, with flanges
- Copper tubes and aluminium fins
- Two or four row
- Supplied factory fitted or supplied loose
- Maximum operating pressure 16 bar
- Horizontal water connections

### Materials

- Casing from galvanised sheet steel
- Attenuator section lined with mineral wool having glass fibre facing suitable of air velocities upto 20 m/s. Material rating A2, DIN 4102
- Galvanised sheet steel damper blade with TPE elastomer seal
- Aluminium sensor tubes
- Polyurethane plain bearings

## Type TVS-A · TVS-B

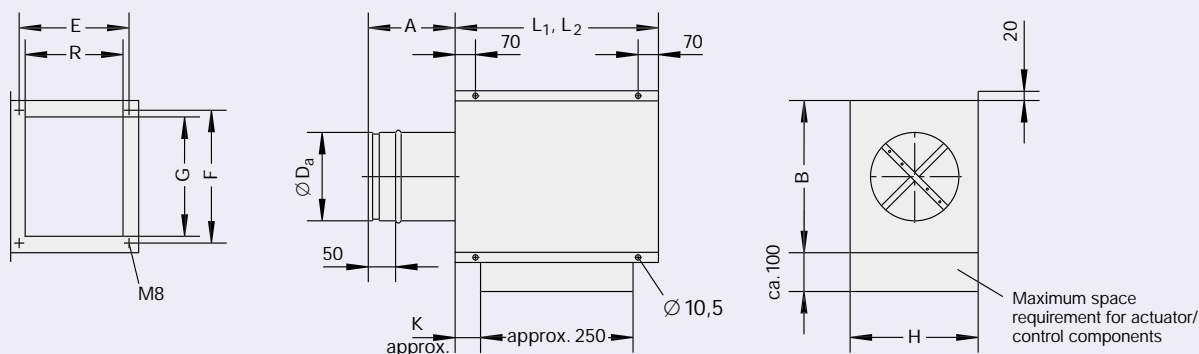

### Duct connection or reheat coil

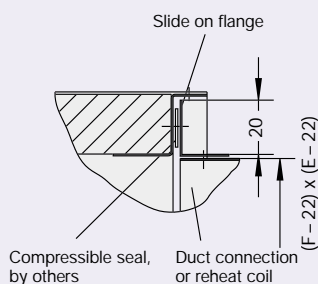

### Reheat coil 1)

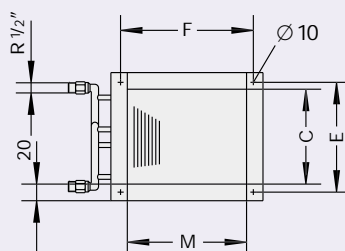

### Outlet Spigot

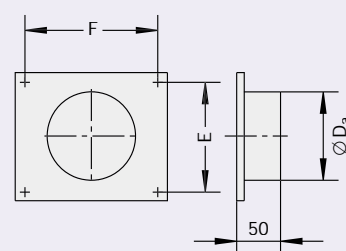

**Table 1:** Dimensions in mm

Size	Duct connections					Casing							
	ØD <sub>a</sub>	E	F	R	G	A	B	C	H	K	L <sub>1</sub> <sup>2)</sup>	L <sub>2</sub> <sup>3)</sup>	M
100	99	210	275	193	258	160	300	188	235	20	400	1320	253
125	124	210	275	193	258	150	300	188	235	20	400	1320	253
160	159	210	275	193	258	200	300	188	235	30	400	1320	253
200	199	255	275	238	258	200	300	233	280	40	400	1320	253
250	249	285	330	268	313	250	355	263	310	50	400	1320	308
315	314	350	375	333	358	250	400	328	375	60	655	1570	353
400	399	420	585	403	568	250	610	398	445	80	765	1680	563

**Table 2:** Weight in kg

Size	TVS-A	TVS-B	Reheat Coil	
			2RR	4RR <sup>4)</sup>
100	6	13	3,0	5,4
125	6	13	3,0	N/A
160	6	13	3,0	N/A
200	8	16	4,8	N/A
250	9	21	6,0	N/A
315	15	27	8,3	N/A
400	23	45	11,8	N/A

Allow access to control components.

- 1) Casing depth for 2RR = 70 and for 4RR = 110
- 2) Compact construction (TVS-A)
- 3) Long construction (TVS-B)
- 4) Size 100 only

# Air Volume Control · Duct Connection

## Control of Room Temperature by Cascade Control

The TVS unit consists of a casing with circular inlet spigot and rectangular outlet connection.

A differential pressure grid incorporated in the circular inlet spigot monitors the air velocity pressure for the volume flowrate present. The room temperature controller resets the volume flowrate controller on the TVS to move values between the factory set minimum and maximum volume flowrate, as a function of the room temperature.

The pressure measured on the differential pressure grid is converted by the transducer, to an electrical input to the velocity controller. This signal is compared with the set point value, and any variance is corrected by the damper actuator so that the air volume is controlled within a small tolerance, over the working pressure range.

- ① Differential pressure grid
- ② Damper blade
- ③ Transducer
- ④ Actuator
- ⑤ Room temperature controller (by others)
- ⑥ Velocity controller

### Volume Flow Control

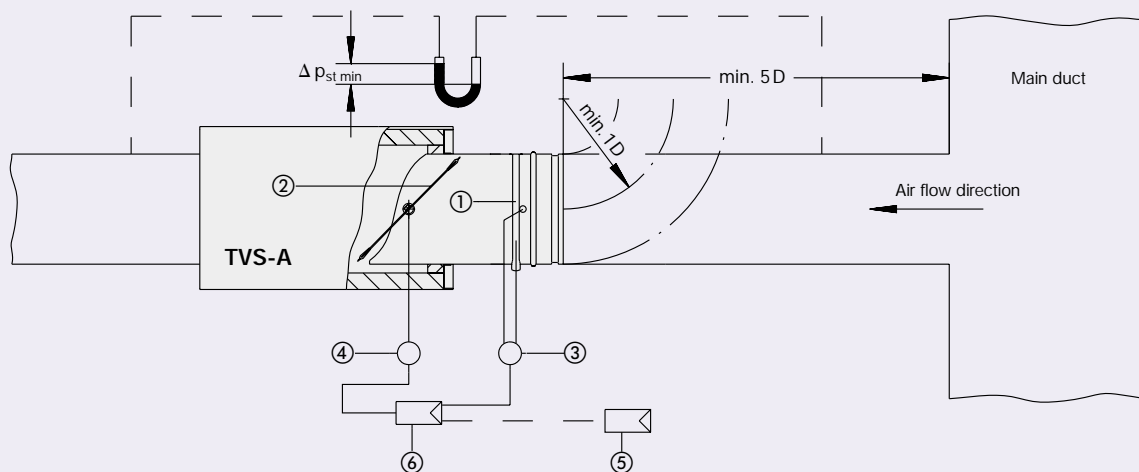

### Control Diagram

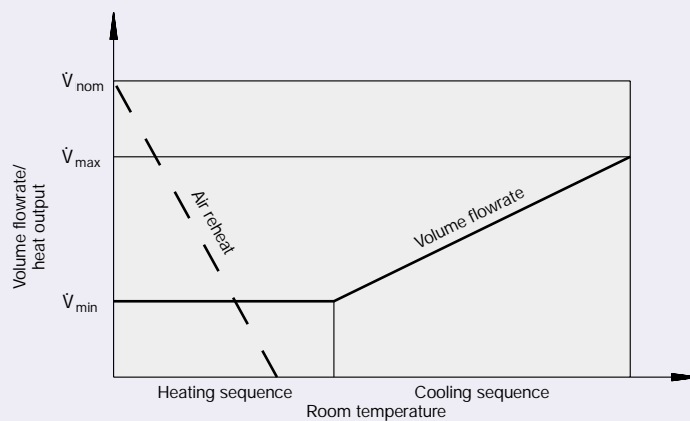

# Nomenclature · Aerodynamic Data

## Nomenclature

$f_m$	in Hz: Octave band centre frequency	RR	: Number of rows
$L_w$	in dB: Sound power level (re 1pW) of regenerated discharge air noise measured in a reverberation chamber	K	: Number of circuits
L	in dB(A): A-weighted sound power level (re 20 $\mu$ Pa), including room attenuation of 8 dB/oct.	$\dot{m}_w$	in kg/s: Mass flow (water)
NC	: Noise criteria of sound pressure spectrum including room attenuation of 8 dB/oct.	$\dot{m}_{wK}$	in kg/s: Mass flow per circuit
$\Delta p_{st}$	in Pa: Static pressure differential	$\dot{Q}$	in kW: Heat output
$\Delta p_{st\ min}$	in Pa: Minimum static pressure differential	$t_e$	in °C: Inlet air temperature
$\Delta p_w$	in Pa: Pressure across differential pressure grid	$t_a$	in °C: Discharge air temperature
$\dot{V}$	in l/s or m <sup>3</sup> /h: Volume flowrate	$t_{wm}$	in °C: Mean water temperature
$\Delta \dot{V}$	in $\pm$ %: Accuracy of set volume flowrate (Poor inlet connections can increase this value)	v	in m/s: Air velocity in section C x M
		$\Delta p_v$	in kPa: Water pressure drop
		$\Delta t$	in K: Air temperature differential
		$\Delta t_w$	in K: Water temperature differential

**Table 3:** Volume flowrate ranges, and minimum pressure differential and flowrate tolerances

Size	$\dot{V}^*)$		$\Delta p_{st\ min}$ in Pa						$\Delta \dot{V}^*)$
			TVS-A	TVS-B	with reheat coil				
					TVS-A		TVS-B		
					2RR	4RR <sup>1)</sup>	2RR	4RR <sup>1)</sup>	
in l/s	in m <sup>3</sup> /h								in $\pm$ %
100	10	36	20	20	25	30	25	30	20
	30	108	20	20	40	60	40	60	8
	60	216	20	40	85	145	105	165	6
	95	342	30	70	130	230	170	270	5
125	15	54	20	20	25	-	25	-	20
	60	216	20	20	40	-	40	-	8
	105	378	20	40	85	-	105	-	6
	150	540	30	70	130	-	170	-	5
160	25	90	20	20	25	-	25	-	20
	100	360	20	20	40	-	40	-	8
	175	630	20	20	85	-	85	-	6
	250	900	20	20	120	-	120	-	5
200	40	144	20	20	25	-	25	-	20
	180	648	20	20	40	-	40	-	8
	315	1134	20	20	85	-	85	-	6
	405	1458	20	20	120	-	120	-	5
250	60	216	20	20	25	-	25	-	20
	270	972	20	20	45	-	45	-	8
	470	1692	20	20	90	-	90	-	6
	615	2214	20	20	150	-	150	-	5
315	105	378	20	20	25	-	25	-	20
	425	1530	20	20	45	-	45	-	8
	745	2682	20	20	90	-	90	-	6
	1025	3690	20	20	150	-	150	-	5
400	170	612	20	20	25	-	25	-	20
	715	2574	20	20	40	-	40	-	8
	1250	4500	20	20	85	-	85	-	6
	1680	6048	20	20	120	-	120	-	5

<sup>\*)</sup> typical values

<sup>1)</sup> size 100 only

# Regenerated Noise TVS-A

## Example

Given: TVS-A Size 200  
 $\dot{V}$  = 45 to 315 l/s or 162 to 1134 m<sup>3</sup>/h  
 $\Delta p_{st}$  = 250 Pa  
 Specified room sound pressure level L 55 dB(A)  
 assuming 8 dB/oct. room attenuation

Required: Regenerated noise L in room  
 at 315 l/s or 1134 m<sup>3</sup>/h

Result: L = 52 dB(A), specification is met

## Correction values

Number of rows	2RR	4RR
$\Delta L$ in dB or NC	6	9

**Table 5:** Regenerated noise TVS-A

Size	$\dot{V}$		$\Delta p_{st} = 100$ Pa														$\Delta p_{st} = 250$ Pa														$\Delta p_{st} = 500$ Pa														$\Delta p_{st} = 1000$ Pa													
			L <sub>w</sub> in dB														L <sub>w</sub> in dB														L <sub>w</sub> in dB														L <sub>w</sub> in dB													
			f <sub>m</sub> in Hz														f <sub>m</sub> in Hz														f <sub>m</sub> in Hz														f <sub>m</sub> in Hz													
			63	125	250	500	1000	2000	4000	8000	L in dB(A)	NC	63	125	250	500	1000	2000	4000	8000	L in dB(A)	NC	63	125	250	500	1000	2000	4000	8000	L in dB(A)	NC	63	125	250	500	1000	2000	4000	8000	L in dB(A)	NC																
100	10	36	28	29	27	22	17	15	<	17	<	26	34	30	28	24	24	21	20	23	17	24	37	33	32	29	31	29	26	29	24	31	40	38	35	30	34	35	34	33	29																	
	40	144	33	46	43	39	27	25	21	15	31	25	41	49	48	44	36	34	31	27	37	30	47	51	51	47	42	40	38	36	41	34	51	54	55	53	48	47	44	42	47	40																
	70	252	43	49	51	45	32	29	26	22	38	32	50	53	55	50	40	38	35	32	43	37	55	56	58	54	46	44	42	39	47	42	57	59	61	59	53	50	48	45	52	47																
	95	342	51	53	54	50	38	34	32	28	42	37	56	58	59	56	45	41	39	36	48	43	59	61	63	60	51	47	45	42	52	48	63	63	66	64	57	54	51	48	57	52																
125	15	54	30	28	32	33	20	18	<	<	23	19	35	29	33	34	27	31	28	24	29	24	38	30	34	35	32	41	41	33	38	35	41	37	36	36	37	45	49	45	44	43																
	60	216	41	40	42	37	29	31	27	15	31	24	46	45	48	43	36	38	35	30	38	30	50	49	52	48	42	43	41	41	43	36	54	50	55	52	48	49	48	47	48	42																
	105	378	49	46	51	47	35	34	31	25	39	34	54	52	55	51	42	42	40	36	44	38	57	56	58	54	47	48	47	45	48	42	60	58	63	58	53	54	51	51	53	46																
	150	540	57	51	56	53	41	40	39	34	45	40	60	56	59	56	47	46	45	41	49	44	62	60	62	59	51	51	49	46	52	47	65	63	66	62	56	57	55	57	57	52																
160	25	90	31	31	38	34	33	31	21	15	30	24	34	32	37	37	35	37	33	28	34	29	37	32	37	40	37	41	42	38	39	36	43	38	40	41	40	43	44	45	42	40																
	100	360	47	44	46	42	35	34	29	25	35	28	52	49	51	48	43	44	40	36	43	36	56	53	55	53	49	51	49	45	49	44	60	53	57	56	56	57	55	54	54	49																
	175	630	55	51	55	50	41	41	36	33	43	37	61	57	59	55	48	49	45	41	49	42	65	60	61	58	54	54	51	48	53	47	68	62	66	63	60	61	58	56	59	53																
	250	900	61	54	63	57	46	46	43	41	50	46	66	59	65	60	52	52	49	47	54	48	70	63	66	62	57	57	54	51	57	50	73	67	71	67	64	64	61	57	63	56																
200	40	144	36	34	42	37	30	28	20	<	30	23	41	36	40	41	36	37	31	25	35	30	44	37	38	44	41	44	40	35	41	36	45	41	42	46	46	48	46	47	46	42																
	180	648	48	47	50	43	41	42	35	27	40	34	54	53	56	51	49	50	46	42	48	42	58	58	60	57	55	56	54	53	54	48	61	60	63	63	62	62	59	59	60	54																
	315	1134	54	56	58	51	44	44	40	36	46	40	61	61	63	57	51	52	50	47	52	45	67	64	66	62	57	58	57	55	58	51	68	68	70	68	65	65	62	61	64	57																
	405	1458	63	61	66	59	51	51	48	44	53	49	66	64	68	63	56	57	54	51	57	52	69	67	70	66	60	61	58	56	61	55	72	72	74	71	67	67	64	63	66	60																
250	60	216	29	37	40	37	34	32	24	<	31	25	34	39	43	44	43	43	36	30	40	35	37	40	45	49	49	51	45	44	47	43	43	46	51	53	54	56	52	52	53	48																
	270	972	46	54	48	42	41	40	32	24	39	32	53	59	55	52	51	50	45	45	49	42	58	63	61	60	58	57	55	61	57	56	62	64	63	67	67	66	61	66	64	61																
	470	1692	50	58	62	51	44	43	37	32	47	44	59	64	64	57	52	49	47	53	47	65	69	66	62	58	59	58	58	59	53	72	74	71	73	70	66	62	64	67	62																	
	615	2214	58	61	64	59	50	48	44	39	52	47	67	67	69	63	56	55	52	48	57	52	73	71	72	66	61	61	58	55	61	56	78	77	76	73	69	68	65	64	68	62																
315	105	378	39	38	38	37	33	32	24	<	31	25	42	40	41	41	38	38	34	27	36	31	45	42	43	44	42	43	41	39	41	35	48	47	47	46	46	47	45	51	46	46																
	425	1530	51	50	47	41	41	41	33	25	39	33	59	56	55	51	51	46	40	49	44	65	61	61	58	58	59	55	52	56	51	67	65	64	66	64	65	62	59	63	57																	
	745	2682	58	59	57	50	43	43	37	30	45	38	65	64	62	56	53	49	44	52	46	70	68	66	61	60	61	58	54	59	53	78	74	71	69	68	68	65	62	66	60																	
	1025	3690	64	63	67	59	49	48	45	41	53	50	72	68	70	62	56	56	53	49	58	54	78	71	72	65	61	62	59	55	61	56	83	79	76	71	69	69	66	63	68	61																
400	170	612	40	38	41	38	32	31	23	<	31	24	45	40	42	42	38	39	34	26	37	31	48	41	42	45	43	45	42	38	42	37	50	46	45	47	47	49	46	50	47	45																
	715	2574	53	50	49	43	42	42	35	27	40	34	59	57	56	52	51	51	47	42	49	44	64	62	61	59	57	58	56	54	56	50	67	65	64	66	64	64	61	60	62	56																
	1250	4500	59	60	58	51	45	44	40	34	46	40	66	65	63	57	53	53	50	47	53	46	71	68	67	62	59	60	58	56	59	52	76	73	72	70	67	68	65	63	66	60																
	1680	6048	66	64	67	60	51	51	48	43	54	50	72	68	70	63	57	57	55	51	58	54	76	71	72	66	61	62	60	57	62	56	80	78	76	72	69	69	66	64	68	61																

< indicates values lower than 15

# Regenerated Noise TVS-B

## Example

Given: TVS-B Size 160  
 $\dot{V} = 175 \text{ l/s}$  or  $630 \text{ m}^3/\text{h}$   
 $\Delta p_{st} = 250 \text{ Pa}$   
 Specified room sound pressure level 45 dB(A)  
 assuming 4 dB/oct. room attenuation

Required: Regenerated noise L in room  
 at  $175 \text{ l/s}$  or  $630 \text{ m}^3/\text{h}$

## Correction values

Number of rows	2RR	4RR
$\Delta L$ in dB or NC	6	9

## Calculations

$f_m$	63	125	250	500	1k	2k	4k	8k
$L_w$	54	52	55	47	26	17	27	27
Duct attenuation <sup>1)</sup>	0	0	0	6	8	4	3	3
Room attenuation <sup>1)</sup>	4	4	4	4	4	4	4	4
	50	48	51	37	14	9	20	20
A-weighting	-26	-16	-9	-3	0	+1	+1	-1
Corrected level	24	32	42	34	14	10	21	19

<sup>1)</sup> see e. g. VDI 2081

Result: L approx. 43 dB(A) based on logarithmic addition, specification is met.

**Table 6:** Regenerated Noise TVS-B

Size	$\dot{V}$		$\Delta p_{st} = 100 \text{ Pa}$														$\Delta p_{st} = 250 \text{ Pa}$														$\Delta p_{st} = 500 \text{ Pa}$														$\Delta p_{st} = 1000 \text{ Pa}$													
			$L_w$ in dB														$L_w$ in dB														$L_w$ in dB														$L_w$ in dB													
			$f_m$ in Hz														$f_m$ in Hz														$f_m$ in Hz														$f_m$ in Hz													
			63	125	250	500	1000	2000	4000	8000	L in dB(A)	NC	63	125	250	500	1000	2000	4000	8000	L in dB(A)	NC	63	125	250	500	1000	2000	4000	8000	L in dB(A)	NC	63	125	250	500	1000	2000	4000	8000	L in dB(A)	NC																
100	10	36	28	29	27	22	17	15	<	<	17	<	<	26	34	30	28	24	24	21	20	23	17	24	37	33	32	29	31	29	26	29	24	31	40	38	35	30	34	35	34	33	29															
	40	144	33	46	43	39	27	25	21	15	31	25	41	49	48	44	36	34	31	27	37	30	47	51	51	47	42	40	38	36	41	34	51	54	55	53	48	47	44	42	47	40																
	70	252	43	49	51	45	32	29	26	22	38	32	50	53	55	50	40	38	35	32	43	37	55	56	58	54	46	44	42	39	47	42	57	59	61	59	53	50	48	45	52	47																
	95	342	51	53	54	50	38	34	32	28	42	37	56	58	59	56	45	41	39	36	48	43	59	61	63	60	51	47	45	42	52	48	63	63	66	64	57	54	51	48	57	52																
125	15	54	26	23	29	27	<	<	<	<	18	<	27	26	27	25	<	<	20	16	18	15	27	28	26	24	<	<	26	20	21	21	41	37	32	27	19	20	32	30	28	27																
	60	216	36	36	38	29	<	<	<	24	17	39	42	44	35	15	<	20	22	30	23	42	46	49	40	18	<	27	30	34	29	47	46	50	43	27	22	33	35	37	30																	
	105	378	48	44	48	40	<	<	16	<	33	28	48	49	52	43	18	<	25	24	37	32	49	53	54	46	22	<	32	33	40	35	53	55	59	50	30	24	37	40	45	41																
	150	540	50	48	53	46	23	<	23	23	39	34	52	53	56	49	25	17	30	30	42	37	54	57	58	51	27	20	35	36	44	39	57	60	63	54	33	26	40	43	48	45																
160	25	90	34	20	34	28	<	<	<	20	<	41	28	34	31	16	<	21	18	23	17	46	34	34	34	20	<	27	23	26	22	43	38	36	36	26	21	34	35	31	30																	
	100	360	43	38	40	32	<	<	<	26	19	47	44	47	40	20	<	24	25	33	27	51	49	52	47	27	<	33	34	39	33	54	50	55	49	35	22	38	41	42	36																	
	175	630	49	47	51	42	21	<	<	37	32	54	52	55	47	26	17	27	27	41	36	58	56	58	51	30	20	36	37	44	39	62	59	62	55	38	25	40	44	49	45																	
	250	900	53	51	60	50	30	23	29	29	45	41	59	56	61	54	33	26	34	35	47	43	63	59	63	56	35	28	38	39	49	45	67	64	67	60	41	30	42	46	53	50																
200	40	144	41	35	40	32	<	<	<	26	18	41	35	37	34	17	16	20	19	26	20	42	36	34	36	21	20	27	25	28	22	41	38	35	34	23	22	28	33	29	29																	
	180	648	43	45	48	38	18	<	18	<	33	27	49	50	53	45	26	19	30	28	39	34	53	55	57	51	31	25	39	40	44	38	56	56	59	55	40	30	41	45	47	43																
	315	1134	52	53	56	47	27	23	26	26	41	37	57	57	60	52	32	28	35	35	45	41	61	60	62	55	36	33	41	42	49	45	64	65	68	61	43	36	45	49	54	51																
	405	1458	57	58	63	55	36	33	36	34	48	45	63	62	66	58	39	36	41	40	52	49	67	65	68	61	42	39	44	44	54	51	70	69	71	65	47	42	48	51	58	55																
250	60	216	30	38	36	31	<	<	<	24	17	28	34	36	34	16	18	22	20	25	19	27	31	36	35	20	23	28	25	28	23	34	36	36	31	20	21	27	30	27	26																	
	270	972	40	53	45	37	19	16	<	33	26	48	58	52	45	27	26	28	33	39	32	54	61	57	52	32	33	40	47	46	42	58	61	60	59	42	37	45	52	51	47																	
	470	1692	49	58	54	46	27	25	26	22	40	34	55	63	60	51	33	32	36	36	46	42	59	67	64	56	38	38	44	46	51	47	66	71	68	64	45	43	47	51	56	52																
	615	2214	55	61	59	54	35	34	36	33	46	41	61	66	66	58	40	39	41	39	52	49	66	69	71	61	43	43	45	43	56	55	68	73	74	67	49	48	50	51	60	59																
315	105	378	29	36	37	32	<	<	<	24	18	37	39	39	36	19	20	25	25	28	22	44	42	41	40	23	25	35	36	34	31	45	46	44	39	25	27	38	47	40	42																	
	425	1530	46	50	47	37	22	24	23	16	33	26	53	55	54	47	29	31	34	32	41	35	58	59	60	53	34	35	43	44	47	41	61	61	61	60	42	40	47	50	51	48																
	745	2682	54	59	56	47	30	30	29	26	42	38	60	63	61	52	36	37	39	36	47	43	64	66	65	57	41	42	46	44	51	48	68	70	69	64	46	46	49	51	57	52																
	1025	3690	60	61	65	55	37	37	36	35	50	48	64	65	68	58	42	42	43	41	53	52	68	68	71	61	45	46	48	46	56	55	71	72	74	66	50	51	53	53	60	59																
400	170	612	43	39	40	35	23	17	<	28	21	45	40	40	39	29	26	25	24	30	25	46	41	40	41	33	32	35	33	34	29	48	44	42	41	36	35	38	43	38	38																	
	715	2574	50	49	48	41	31	28	27	20	35	28	57	55	55	49	39	37	39	35	43	36	62	60	60	56	46	43	48	47	49	43	64	63	62	62	53	48	52	53	54	50																
	1250	4500	58	58	57	49	36	34	33	29	44	39	64	63	62	55	43	42	43	40	49	44	68	66	65	59	49	48	50	49	53	48	74	71	70	66	56	53	56	57	59	55																
	1680	6048	63	63	66	58	43	42	42	39	52	49	70	67	69	61	48	47	48	45	55	53	75	70	71	64	52	52	53	51	58	55	79	76	74	69	59	57	58	62	59																	

< indicates values lower than 15



# Case Radiated Noise TVS-B

## Example

Given: TVS-B Size 250  
 $\dot{V}$  = 139 to 470 l/s or 500 to 1692 m<sup>3</sup>/h  
 $\Delta p_{st}$  = 250 Pa  
 Specified room sound pressure level L 45 dB(A)  
 assuming 8 dB/oct. room attenuation

Required: Case radiated noise L in room  
 at 470 l/s or 1692 m<sup>3</sup>/h

Result: L = 43 dB(A specification is met)

**Table 8:** Case Radiated Noise TVS-B

Size	$\dot{V}$		$\Delta p_{st} = 100$ Pa														$\Delta p_{st} = 250$ Pa														$\Delta p_{st} = 500$ Pa														$\Delta p_{st} = 1000$ Pa													
			L <sub>w</sub> in dB														L <sub>w</sub> in dB														L <sub>w</sub> in dB														L <sub>w</sub> in dB													
			f <sub>m</sub> in Hz														f <sub>m</sub> in Hz														f <sub>m</sub> in Hz														f <sub>m</sub> in Hz													
			63	125	250	500	1000	2000	4000	8000	L in dB(A)	NC	63	125	250	500	1000	2000	4000	8000	L in dB(A)	NC	63	125	250	500	1000	2000	4000	8000	L in dB(A)	NC	63	125	250	500	1000	2000	4000	8000	L in dB(A)	NC																
100	10	36	29	16	28	<	<	<	<	<	<	<	<	<	<	<	<	<	<	35	26	33	21	18	15	19	23	20	19	40	33	36	27	22	18	24	32	26	28	44	37	42	32	27	24	29	40	33	35									
	40	144	45	34	42	27	<	<	<	<	26	21	48	41	48	33	23	21	21	25	32	27	51	47	52	38	31	27	27	34	37	33	54	50	55	45	39	34	33	41	41	41	36															
	70	252	46	39	50	32	18	16	<	<	34	30	52	48	56	38	27	24	22	26	40	37	56	54	60	43	34	30	29	36	44	42	60	55	61	49	42	37	36	41	46	43																
	95	342	45	36	46	27	18	23	<	<	30	25	54	47	54	39	29	29	22	25	38	35	61	55	60	48	37	33	30	35	45	42	61	60	65	54	44	41	38	42	50	48																
125	15	54	21	31	26	21	<	<	<	<	15	<	27	31	23	21	<	<	<	<	15	<	31	30	21	22	<	<	<	<	16	<	36	38	29	26	21	20	26	35	28	31																
	60	216	33	45	33	23	<	<	<	<	23	15	38	49	39	31	20	17	16	16	28	21	41	53	43	36	26	20	18	19	32	25	43	54	46	41	34	28	28	35	36	30																
	105	378	48	51	44	33	25	18	<	<	31	23	49	57	47	37	28	23	21	20	35	30	50	61	49	41	30	27	28	26	39	36	51	61	54	47	37	32	33	37	42	37																
	150	540	50	54	48	42	35	27	22	<	36	29	52	60	51	45	35	30	29	23	40	35	55	64	53	47	35	33	34	32	43	40	56	66	58	50	39	35	37	39	46	43																
160	25	90	37	36	21	22	<	<	<	<	16	<	39	33	23	25	17	16	<	<	18	<	40	31	25	26	21	19	<	<	20	<	30	35	30	28	24	21	20	24	23	20																
	100	360	50	49	36	28	19	<	<	27	21	52	54	42	35	25	19	17	18	32	26	54	57	46	40	30	24	21	23	36	31	52	58	51	44	38	31	26	30	39	32																	
	175	630	52	54	43	36	27	19	16	<	33	27	57	60	48	41	30	24	21	18	38	34	60	64	52	44	33	27	24	22	42	40	62	67	57	50	40	33	28	33	46	44																
	250	900	57	57	48	44	34	27	20	<	38	31	61	62	52	47	36	29	24	<	42	38	64	67	56	49	38	31	27	<	45	43	68	73	62	53	43	35	31	34	51	51																
200	40	144	34	42	27	24	<	<	<	<	20	<	35	43	31	29	20	18	17	15	23	<	36	43	34	33	27	22	20	18	26	18	35	46	37	36	32	28	27	29	31	25																
	180	648	49	53	37	23	23	15	<	30	26	53	58	42	32	28	21	21	22	35	32	56	61	46	39	33	26	28	30	39	36	59	64	52	49	41	34	31	37	44	40																	
	315	1134	53	59	45	30	29	20	16	<	36	34	60	64	49	38	33	26	25	24	41	40	65	68	52	44	36	30	32	33	45	45	64	69	57	50	44	37	35	39	48	47																
	405	1458	59	62	50	44	39	29	25	21	41	37	65	67	54	46	40	32	30	28	45	44	69	70	56	48	41	34	34	33	48	48	70	74	61	54	46	38	36	39	52	53																
250	60	216	37	33	28	25	15	<	<	18	<	36	34	31	28	24	24	26	25	25	21	34	35	33	30	31	34	37	36	34	31	37	39	40	37	38	41	44	45	41	40																	
	270	972	57	50	38	31	24	18	<	30	22	61	57	45	39	31	29	28	30	36	30	64	61	50	45	36	37	40	44	42	40	64	61	54	50	44	42	45	49	46	44																	
	470	1692	60	59	51	41	32	26	20	<	39	33	67	63	55	45	36	33	31	28	43	39	72	67	57	49	39	39	40	47	44	69	71	63	55	45	42	43	47	51	48																	
	615	2214	59	55	50	48	40	35	30	25	41	36	67	64	56	51	42	38	36	33	46	40	73	71	61	54	43	41	40	38	51	49	75	72	66	58	47	44	46	47	54	51																
315	105	378	41	37	29	24	20	25	17	<	22	17	43	40	34	31	31	33	31	30	31	26	44	43	38	36	39	40	42	44	40	39	52	51	44	42	44	48	50	53	48	48																
	425	1530	57	52	41	33	30	26	20	<	32	25	62	58	47	40	37	36	34	31	38	32	66	62	52	45	42	43	44	45	45	40	67	64	56	53	49	50	51	53	51	48																
	745	2682	60	58	52	43	39	34	28	22	40	32	66	63	55	46	42	41	38	35	44	38	70	66	58	48	44	46	46	45	48	43	74	72	63	56	49	52	53	54	54	51																
	1025	3690	64	59	57	51	46	42	37	33	45	38	70	64	60	52	48	46	43	40	49	43	75	68	63	53	49	49	48	46	52	46	78	75	67	58	51	53	54	54	57	55																
400	170	612	46	41	34	28	24	31	21	16	27	23	47	44	38	35	35	38	35	34	35	31	48	47	42	40	43	44	46	48	44	43	60	57	49	47	49	53	55	58	53	53																
	715	2574	60	53	46	35	31	30	23	<	34	26	67	60	53	43	38	40	38	31	42	35	73	66	58	49	43	47	49	46	49	43	74	68	62	57	53	54	55	54	49																	
	1250	4500	64	59	53	44	42	39	31	27	42	33	69	65	58	48	44	44	41	39	47	41	73	69	63	50	45	48	50	47	51	47	77	75	68	58	50	54	57	52	57	54																
	1680	6048	73	60	57	48	47	46	40	33	47	42	77	65	61	52	49	49	45	43	50	49	81	69	64	54	50	50	49	50	53	54	84	76	68	59	52	54	55	50	58	58																

< indicates for values lower than 15

# Reheat Coil Selection

## 1 Mean Water pressure drop for sizes 100 to 400 calculation

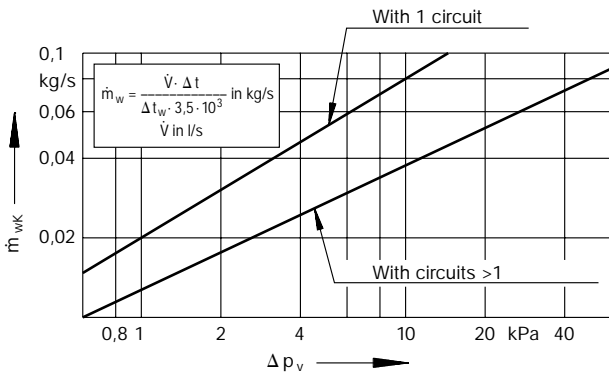

## Calculation of water pressure drop

Two- or four row reheat coil

$$\dot{m}_{wK} = \frac{\dot{m}_w}{K} \text{ in kg/s}$$

## Number of circuits

Size		100	125	160	200	250	315	400
K	2RR	1	1	1	2	2	2	4
	4RR	1	N/A	N/A	N/A	N/A	N/A	N/A

## 2 Selection diagram

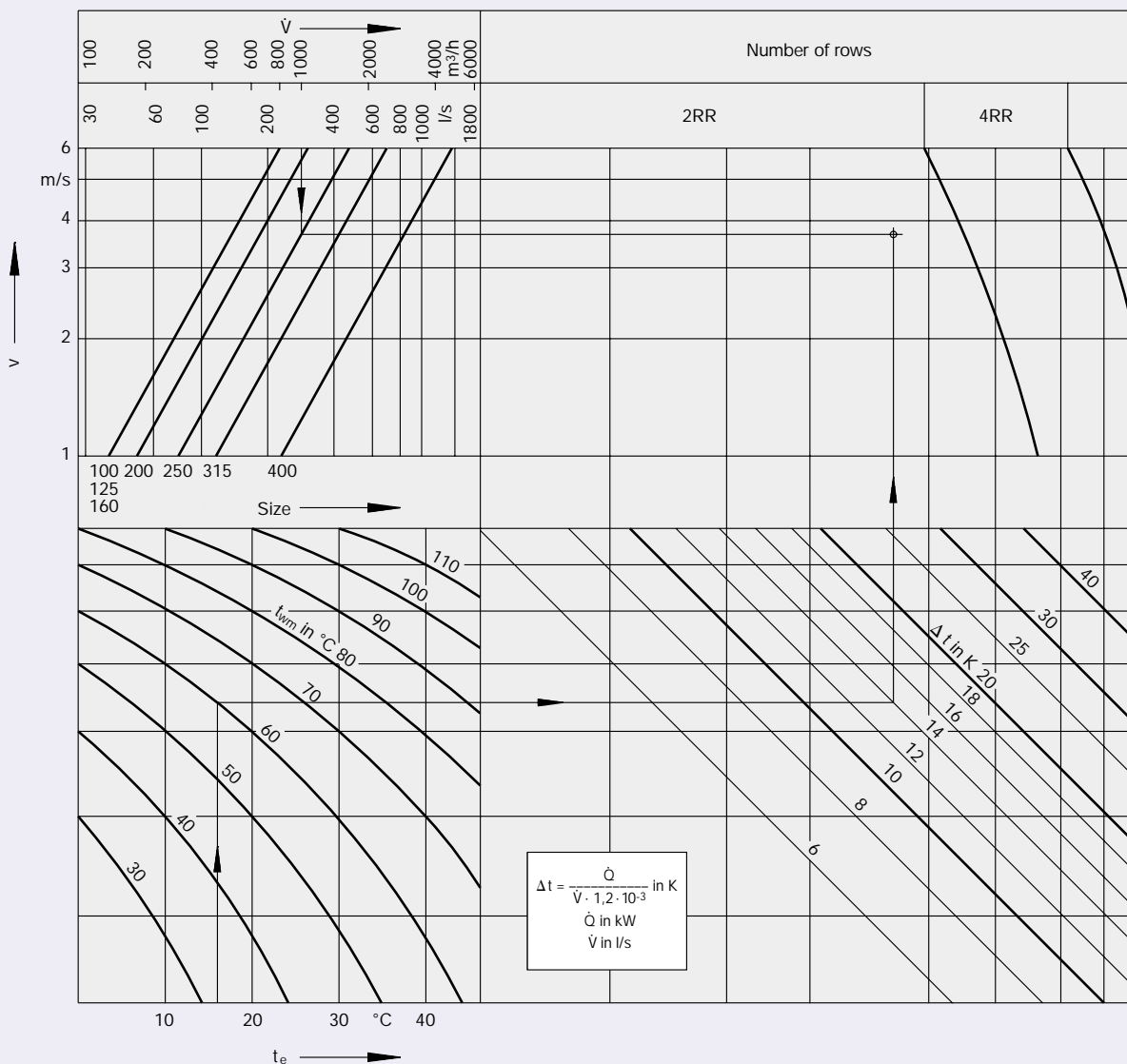

# Order Details

## Specification Text

VAV terminal box for supply air on variable volume systems. Box consists of casing with control damper, with closed blade leakage rate to DIN 1946 Part 4, averaging differential pressure grid and factory fitted and wired control components. Each VAV box is tested and the volume flowrates set in the factory. Minimum and maximum volume flowrate settings can be measured and adjusted on site.

Case leakage flow to Class II, VDI 3803 or DIN V 24 194, Part 2. Static differential pressure range 20 to 1500 Pa. Volume flowrate range approx. 10:1, depending on type of control.

## Controls:

- Variable volume flowrate control, electronic velocity controller. Actual velocity signal can be measured, differential pressure measured dynamically. Electrical supply: 24 VAC, control signal 2 to 10 VDC/0 to 10 VDC

## Materials:

Galvanised sheet steel casing, sheet steel damper with TPE elastomer seal, aluminium sensor tubes, polyurethane plain bearings.

## Order Code

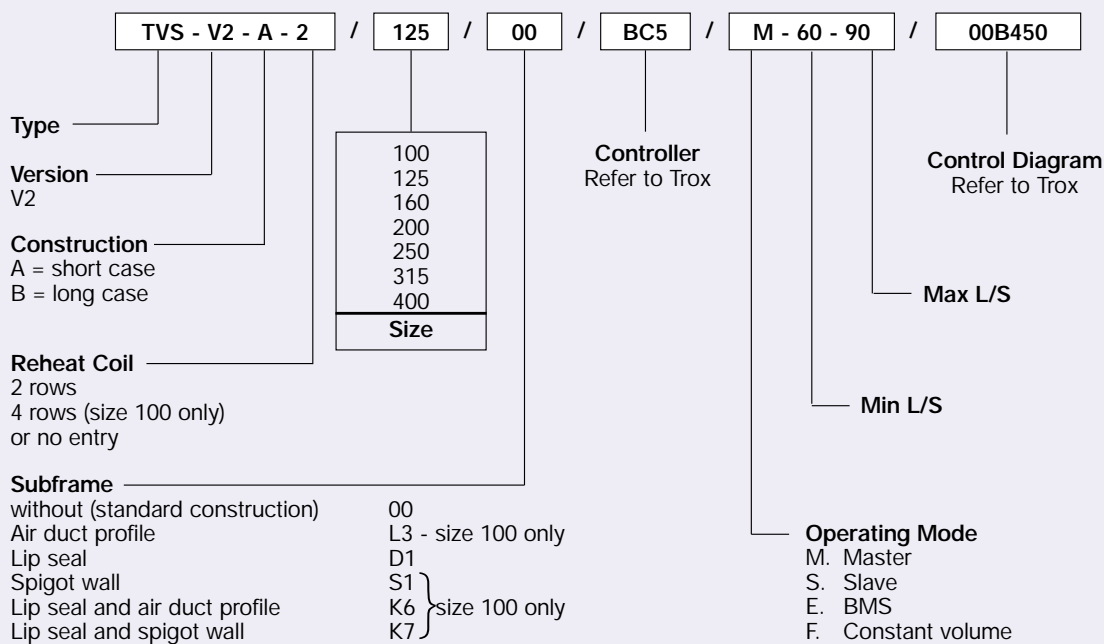

## Order Example

Make: TROX  
Type: TVS - V2 - A - 2 / 125 / 00 / BC5 / M - 60 - 90 / 00B450

